

Industrial PC Platform

NY-series

## NYP Industrial Panel PC

Hardware User's Manual

NYP□□

Industrial Panel PC



#### **NOTE**

All rights reserved. No part of this publication may be reproduced, stored in a retrieval system, or transmitted, in any form, or by any means, mechanical, electronic, photocopying, recording, or otherwise, without the prior written permission of OMRON.

No patent liability is assumed with respect to the use of the information contained herein. Moreover, because OMRON is constantly striving to improve its high-quality products, the information contained in this manual is subject to change without notice. Every precaution has been taken in the preparation of this manual. Nevertheless, OMRON assumes no responsibility for errors or omissions. Neither is any liability assumed for damages resulting from the use of the information contained in this publication.

#### **Trademarks**

- Sysmac and SYSMAC are trademarks or registered trademarks of OMRON Corporation in Japan and other countries for OMRON factory automation products.
- Windows is a registered trademark of Microsoft Corporation in the USA and other countries.
- The SD and SDHC logos are trademarks of SD-3C, LLC. 
- CFAST is a registered trademark of CompactFlash Association.
- Intel, the Intel Logo, Celeron and Intel Core are trademarks of Intel Corporation in the U.S. and/or other countries.

Other company names and product names in this document are the trademarks or registered trademarks of their respective companies.

#### **Copyrights**

Microsoft product screen shots reprinted with permission from Microsoft Corporation.

# Introduction

Thank you for purchasing the Industrial Panel PC.

This manual contains information that is necessary to use the Industrial Panel PC (hereafter also named Panel PC). Please read this manual and make sure you understand the functionality and performance of the Panel PC before attempting to use it.

Keep this manual in a safe place where it will be available for reference during operation.

## Intended Audience

This manual is intended for the following personnel, who must also have knowledge of electrical systems (an electrical engineer or the equivalent).

- Personnel in charge of introducing Factory Automation systems.
- Personnel in charge of designing Factory Automation systems.
- Personnel in charge of installing and maintaining Factory Automation systems.
- Personnel in charge of managing Factory Automation systems and facilities.

## Applicable Products

This manual covers following Industrial Panel PC products:

Product	Model
Industrial Panel PC, 12 inch	NYP□□-□□□□□-12□□□□□□
Industrial Panel PC, 15 inch	NYP□□-□□□□□-15□□□□□□
Industrial Panel PC, 19 inch	NYP□□-□□□□□-19□□□□□□



### Additional Information

Refer to *1-4 Product Configuration Panel PC* on page 1-5 for configuration details.



# Sections in this Manual

---

<b>1</b>	Overview	<b>1</b>
<b>2</b>	System Configurations	<b>2</b>
<b>3</b>	Hardware	<b>3</b>
<b>4</b>	Specifications	<b>4</b>
<b>5</b>	Installation	<b>5</b>
<b>6</b>	Operating Procedures	<b>6</b>
<b>7</b>	Maintenance	<b>7</b>
<b>A</b>	Appendices	<b>A</b>

# CONTENTS

---

<b>Introduction .....</b>	<b>1</b>
Intended Audience .....	1
Applicable Products .....	1
<b>Sections in this Manual .....</b>	<b>3</b>
<b>Manual Information .....</b>	<b>9</b>
Page Structure .....	9
Special Information .....	10
<b>Terms and Conditions Agreement.....</b>	<b>11</b>
Warranty, Limitations of Liability .....	11
Application Considerations .....	12
Disclaimers .....	13
<b>Safety Precautions.....</b>	<b>14</b>
Definition of Precautionary Information.....	14
Symbols .....	14
Warnings.....	15
Cautions.....	18
<b>Precautions for Safe Use .....</b>	<b>19</b>
Disassembly, Dropping, Mounting, Installation and Storage .....	19
Wiring.....	19
Power Supply Design and Turning ON/OFF the Power Supply.....	20
Actual Operation .....	20
Operation .....	21
General Communications .....	21
Battery and Fan Replacement .....	21
Cleaning, Maintenance and Disposal .....	22
VESA Mount Bracket .....	22
<b>Precautions for Correct Use .....</b>	<b>23</b>
Storage, Installation and Mounting .....	23
Wiring.....	23
Actual Operation and Operation .....	24
Battery Replacement .....	24
SD Memory Cards .....	25
Cleaning and Maintenance .....	25
VESA Mount Bracket .....	25
<b>Regulations and Standards .....</b>	<b>26</b>
Conformance to EU Directives .....	26
Conformance to KC Certification .....	27
Conformance to UL and CSA Standards.....	27
Software Licenses and Copyrights .....	27
<b>Related Manuals.....</b>	<b>28</b>
Related Panel PC Manual .....	28
Related Products Manuals.....	28
Industrial Monitor Manual .....	29
<b>Terminology and Abbreviations .....</b>	<b>30</b>
Industrial PC Platform .....	30
Hardware .....	30
Software.....	31

Revision History.....	32
-----------------------	----

## Section 1 Overview

1-1	Intended Use .....	1-2
1-2	Hardware Features.....	1-3
1-3	ID Information Label .....	1-4
1-4	Product Configuration Panel PC .....	1-5
1-5	Overall Setup Procedure .....	1-7
1-6	Industrial PC Platform Overview .....	1-8
1-6-1	Industrial Monitor .....	1-9
1-6-2	Industrial Box PC .....	1-10
1-6-3	Industrial Panel PC .....	1-10

## Section 2 System Configurations

2-1	Configuration for NYB and NYP .....	2-2
-----	-------------------------------------	-----

## Section 3 Hardware

3-1	Layers and Components .....	3-3
3-1-1	Cooling Layer .....	3-4
3-1-2	Base Layer .....	3-5
3-1-3	Expansion Layer (Optional).....	3-6
3-1-4	Display Layer .....	3-7
3-2	LED Indicators.....	3-8
3-2-1	LED Indicators Display Layer .....	3-8
3-2-2	LED Indicators Base Layer .....	3-10
3-3	Power Button.....	3-12
3-4	Connectors .....	3-13
3-4-1	Power Connector .....	3-13
3-4-2	I/O Connector.....	3-13
3-4-3	USB Connectors .....	3-14
3-4-4	Ethernet Connectors .....	3-15
3-4-5	DisplayPort Connector (Optional) .....	3-15
3-4-6	DVI Connector (Optional).....	3-16
3-4-7	RS-232C Connector (Optional) .....	3-17
3-4-8	DVI-D Connector (Optional) .....	3-17
3-4-9	NY Monitor Link Connector (Optional) .....	3-18
3-4-10	Ethernet Connector (Optional) .....	3-19
3-5	SD Memory Card Slot (Optional) .....	3-20
3-6	CFast Card, Battery Slot (Optional).....	3-21
3-6-1	CFast Card Slot (Optional).....	3-22
3-6-2	Battery Slot (Optional).....	3-22
3-7	Drive Bays .....	3-23
3-8	PCIe Card Slot.....	3-24
3-9	Spare Parts .....	3-25
3-9-1	Battery.....	3-25
3-9-2	Fan Unit.....	3-25
3-9-3	Accessory Kit .....	3-26
3-9-4	Connectors .....	3-26

<b>3-10</b>	<b>Optional Hardware</b> .....	<b>3-27</b>
3-10-1	VESA Mount Brackets .....	3-27
3-10-2	SD Memory Cards .....	3-28
3-10-3	CFast Cards .....	3-28
3-10-4	HDD and SSD Storage Devices .....	3-29
3-10-5	DVI Cables .....	3-31
3-10-6	USB Type-A to USB Type-B Cables .....	3-31
3-10-7	NY Monitor Link Cables .....	3-32
3-10-8	Industrial Monitor .....	3-35
3-10-9	Power Supply .....	3-35
3-10-10	UPS .....	3-36
3-10-11	UPS Communication Cable .....	3-36

## Section 4 Specifications

---

<b>4-1</b>	<b>General Specifications</b> .....	<b>4-2</b>
4-1-1	Dimensions and Weight .....	4-2
4-1-2	General Electrical Specifications .....	4-6
4-1-3	Power Consumption Specifications .....	4-7
4-1-4	Power Supply Specifications .....	4-9
4-1-5	CPU Specifications .....	4-10
4-1-6	Memory Specifications .....	4-15
4-1-7	Storage Device Specifications .....	4-17
4-1-8	PCIe Card Specifications .....	4-21
4-1-9	VESA Mount Brackets and Handle Specifications .....	4-23
<b>4-2</b>	<b>Connector Specifications</b> .....	<b>4-26</b>
4-2-1	Power Connector Specifications .....	4-26
4-2-2	I/O Connector Specifications .....	4-27
4-2-3	USB Connector Specifications .....	4-32
4-2-4	Ethernet Connector Specifications .....	4-33
4-2-5	DVI Connector Specifications .....	4-35
4-2-6	DisplayPort Connector Specifications .....	4-36
4-2-7	DVI-D Connector Specifications .....	4-37
4-2-8	RS-232C Connector Specifications .....	4-38
4-2-9	NY Monitor Link Connector Specifications .....	4-38
<b>4-3</b>	<b>Display Specifications</b> .....	<b>4-40</b>
<b>4-4</b>	<b>Environmental Specifications</b> .....	<b>4-42</b>
4-4-1	Operation Environment Specifications .....	4-42
4-4-2	Temperature and Humidity Specifications .....	4-43
4-4-3	Recycling Specifications .....	4-48

## Section 5 Installation

---

<b>5-1</b>	<b>Unpack</b> .....	<b>5-2</b>
5-1-1	Unpack Procedure .....	5-2
5-1-2	Items Supplied .....	5-3
<b>5-2</b>	<b>Install Options</b> .....	<b>5-4</b>
5-2-1	Install a Drive .....	5-4
5-2-2	Install the PCIe Card .....	5-8
<b>5-3</b>	<b>Mount</b> .....	<b>5-14</b>
5-3-1	Installation Method in Control Panels .....	5-14
5-3-2	Product Orientation .....	5-15
5-3-3	Temperature .....	5-16
5-3-4	Humidity .....	5-18
5-3-5	Vibration and Shock .....	5-18
5-3-6	Atmosphere .....	5-19
5-3-7	Electrical Environment .....	5-19
5-3-8	Panel Mount Procedure .....	5-25

5-3-9	VESA Mount Procedure .....	5-28
<b>5-4</b>	<b>Wire .....</b>	<b>5-31</b>
5-4-1	Wiring Warnings and Cautions .....	5-31
5-4-2	Ground .....	5-31
5-4-3	Wire the Power Connector .....	5-38
5-4-4	Wire the I/O Connector .....	5-41
<b>5-5</b>	<b>Connect.....</b>	<b>5-44</b>
5-5-1	Connector Identification .....	5-44
5-5-2	Connection Procedure .....	5-46
<b>5-6</b>	<b>Initial Power ON .....</b>	<b>5-48</b>
5-6-1	Initial Power ON Procedure .....	5-48
5-6-2	Windows Startup First Time .....	5-50
<b>5-7</b>	<b>Install Software .....</b>	<b>5-52</b>
<b>5-8</b>	<b>Connect UPS .....</b>	<b>5-53</b>
5-8-1	Connect UPS Using the USB Connector .....	5-54
5-8-2	Connect UPS Using the I/O Connector .....	5-56
<b>5-9</b>	<b>Create Backup and Repair Data .....</b>	<b>5-60</b>

## Section 6 Operating Procedures

<b>6-1</b>	<b>Touchscreen Operation.....</b>	<b>6-2</b>
6-1-1	Touchscreen Operation - Capacitive Touch .....	6-2
<b>6-2</b>	<b>Power ON.....</b>	<b>6-3</b>
6-2-1	Power ON Using the Power Button .....	6-3
6-2-2	Power ON Using the Power ON/OFF Input.....	6-3
6-2-3	Auto Power ON .....	6-4
<b>6-3</b>	<b>Power OFF .....</b>	<b>6-5</b>
6-3-1	Power OFF Using the Power Button .....	6-5
6-3-2	Power OFF Using Windows Shut Down .....	6-5
6-3-3	Power OFF Using the Power ON/OFF Input .....	6-6
6-3-4	Forced Power OFF Using the Power Button .....	6-6
<b>6-4</b>	<b>React to Product Messages .....</b>	<b>6-7</b>
<b>6-5</b>	<b>React to Windows Messages.....</b>	<b>6-8</b>

## Section 7 Maintenance

<b>7-1</b>	<b>Preventive Maintenance .....</b>	<b>7-2</b>
7-1-1	Preventive Maintenance Schedule.....	7-2
7-1-2	Clean the Touchscreen Surface .....	7-3
7-1-3	Clean the Panel PC.....	7-4
7-1-4	Check the Gasket Seal .....	7-4
7-1-5	Minimize LCD Image Retention .....	7-4
<b>7-2</b>	<b>Corrective Maintenance .....</b>	<b>7-5</b>
7-2-1	Warning and Error Messages.....	7-5
7-2-2	Remove the Cover .....	7-7
7-2-3	Replace the Fan Unit .....	7-8
7-2-4	Replace the CJ1W Battery.....	7-10
7-2-5	Replace a Drive.....	7-15
7-2-6	Replace the PCIe Card .....	7-20
7-2-7	Replace the CFAST Card.....	7-25

## Appendices

<b>A-1</b>	<b>BIOS .....</b>	<b>A-2</b>
------------	-------------------	------------

A-1-1	BIOS Overview.....	A-2
A-1-2	BIOS for 4 <sup>th</sup> generation CPUs.....	A-5
A-1-3	BIOS for 7 <sup>th</sup> generation CPUs.....	A-14
A-1-4	BIOS for 11 <sup>th</sup> generation CPU - CVWNA111 CVWNR111 CVWGR111 .....	A-44
A-1-5	BIOS for 11 <sup>th</sup> generation CPU - CQWGA111 .....	A-53
A-1-6	BIOS for Atom CPU - 1AWGR113 .....	A-61
A-1-7	BIOS for Atom CPU - 3AWNR113.....	A-67
<b>A-2</b>	<b>DVI Connector Pin Details.....</b>	<b>A-76</b>
A-2-1	DVI-I Connector Pin Details .....	A-76
A-2-2	DVI-D Connector Pin Details.....	A-77
<b>A-3</b>	<b>RS-232C Connector Pin Details.....</b>	<b>A-79</b>

## Index

---

# Manual Information

This section provides information about this manual.

## Page Structure

The following page structure is used in this manual.

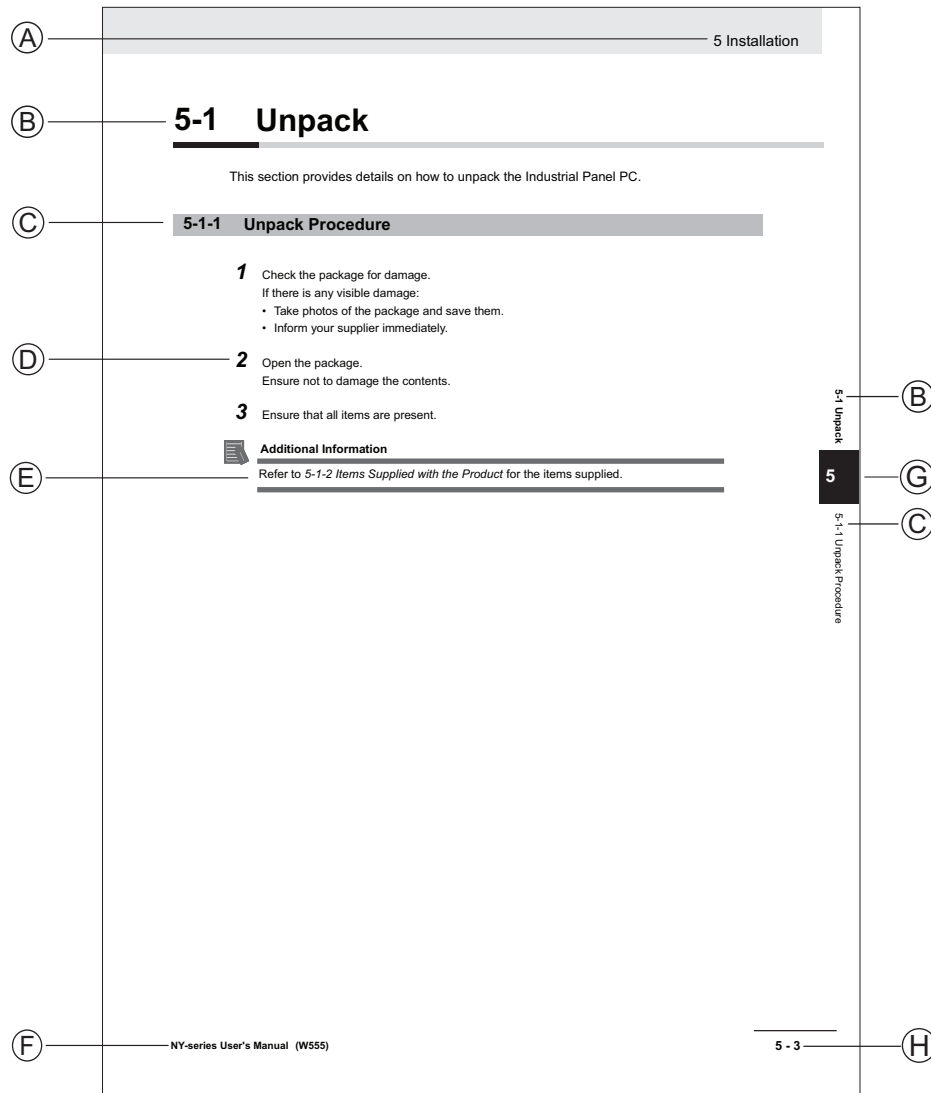

Note: This illustration is provided as a sample. It will not literally appear in this manual.

Item	Explanation	Item	Explanation
A	Level 1 heading	E	Special Information
B	Level 2 heading	F	Manual name
C	Level 3 heading	G	Page tab with the number of the main section
D	Step in a procedure	H	Page number

## Special Information

Special information in this manual is classified as follows:



### **Precautions for Safe Use**

---

Precautions on what to do and what not to do to ensure safe usage of the product.

---



### **Precautions for Correct Use**

---

Precautions on what to do and what not to do to ensure proper operation and performance.

---



### **Additional Information**

---

Additional information to read as required.

This information is provided to increase understanding or make operation easier.

---



### **Version Information**

---

Information on differences in specifications and functionality between different versions.

---

# Terms and Conditions Agreement

---

## Warranty, Limitations of Liability

### Warranties

---

- **Exclusive Warranty**

Omron's exclusive warranty is that the Products will be free from defects in materials and workmanship for a period of twelve months from the date of sale by Omron (or such other period expressed in writing by Omron). Omron disclaims all other warranties, express or implied.

- **Limitations**

OMRON MAKES NO WARRANTY OR REPRESENTATION, EXPRESS OR IMPLIED, ABOUT NON-INFRINGEMENT, MERCHANTABILITY OR FITNESS FOR A PARTICULAR PURPOSE OF THE PRODUCTS. BUYER ACKNOWLEDGES THAT IT ALONE HAS DETERMINED THAT THE PRODUCTS WILL SUITABLY MEET THE REQUIREMENTS OF THEIR INTENDED USE.

Omron further disclaims all warranties and responsibility of any type for claims or expenses based on infringement by the Products or otherwise of any intellectual property right.

- **Buyer Remedy**

Omron's sole obligation hereunder shall be, at Omron's election, to (i) replace (in the form originally shipped with Buyer responsible for labor charges for removal or replacement thereof) the non-complying Product, (ii) repair the non-complying Product, or (iii) repay or credit Buyer an amount equal to the purchase price of the non-complying Product; provided that in no event shall Omron be responsible for warranty, repair, indemnity or any other claims or expenses regarding the Products unless Omron's analysis confirms that the Products were properly handled, stored, installed and maintained and not subject to contamination, abuse, misuse or inappropriate modification. Return of any Products by Buyer must be approved in writing by Omron before shipment. Omron Companies shall not be liable for the suitability or unsuitability or the results from the use of Products in combination with any electrical or electronic components, circuits, system assemblies or any other materials or substances or environments. Any advice, recommendations or information given orally or in writing, are not to be construed as an amendment or addition to the above warranty.

See <https://www.omron.com/global/> or contact your Omron representative for published information.

## Limitation on Liability; Etc

---

OMRON COMPANIES SHALL NOT BE LIABLE FOR SPECIAL, INDIRECT, INCIDENTAL, OR CONSEQUENTIAL DAMAGES, LOSS OF PROFITS OR PRODUCTION OR COMMERCIAL LOSS IN ANY WAY CONNECTED WITH THE PRODUCTS, WHETHER SUCH CLAIM IS BASED IN CONTRACT, WARRANTY, NEGLIGENCE OR STRICT LIABILITY.

Further, in no event shall liability of Omron Companies exceed the individual price of the Product on which liability is asserted.

## Application Considerations

### Suitability of Use

---

Omron Companies shall not be responsible for conformity with any standards, codes or regulations which apply to the combination of the Product in the Buyer's application or use of the Product. At Buyer's request, Omron will provide applicable third party certification documents identifying ratings and limitations of use which apply to the Product. This information by itself is not sufficient for a complete determination of the suitability of the Product in combination with the end product, machine, system, or other application or use. Buyer shall be solely responsible for determining appropriateness of the particular Product with respect to Buyer's application, product or system. Buyer shall take application responsibility in all cases.

NEVER USE THE PRODUCT FOR AN APPLICATION INVOLVING SERIOUS RISK TO LIFE OR PROPERTY OR IN LARGE QUANTITIES WITHOUT ENSURING THAT THE SYSTEM AS A WHOLE HAS BEEN DESIGNED TO ADDRESS THE RISKS, AND THAT THE OMRON PRODUCT(S) IS PROPERLY RATED AND INSTALLED FOR THE INTENDED USE WITHIN THE OVERALL EQUIPMENT OR SYSTEM.

### Programmable Products

---

- Omron Companies shall not be responsible for the user's programming of a programmable Product, or any consequence thereof.
- Omron Companies shall not be responsible for the operation of the user accessible operating system (e.g. Windows, Linux), or any consequence thereof.

## Disclaimers

### Performance Data

---

Data presented in Omron Company websites, catalogs and other materials is provided as a guide for the user in determining suitability and does not constitute a warranty. It may represent the result of Omron's test conditions, and the user must correlate it to actual application requirements. Actual performance is subject to the Omron's Warranty and Limitations of Liability.

### Change in Specifications

---

Product specifications and accessories may be changed at any time based on improvements and other reasons. It is our practice to change part numbers when published ratings or features are changed, or when significant construction changes are made. However, some specifications of the Product may be changed without any notice. When in doubt, special part numbers may be assigned to fix or establish key specifications for your application. Please consult with your Omron's representative at any time to confirm actual specifications of purchased Product.

### Errors and Omissions

---



Information presented by Omron Companies has been checked and is believed to be accurate; however, no responsibility is assumed for clerical, typographical or proofreading errors or omissions.

# Safety Precautions





## Definition of Precautionary Information

The following notation is used in this manual to provide precautions required to ensure safe usage of the Industrial Panel PC. The safety precautions that are provided are extremely important to safety. Always read and heed the information provided in all safety precautions.

The following notation is used.

 <b>WARNING</b>	<p>Indicates a potentially hazardous situation which, if not avoided, could result in death or serious injury. Additionally, there may be severe property damage.</p>
 <b>CAUTION</b>	<p>Indicates a potentially hazardous situation which, if not avoided, may result in minor or moderate injury, or property damage.</p>

## Symbols

	<p>The circle and slash symbol indicates operations that you must not do. The specific operation is shown in the circle and explained in text. This example indicates prohibiting disassembly.</p>
	<p>The triangle symbol indicates precautions (including warnings). The specific operation is shown in the triangle and explained in text. This example indicates a precaution for electric shock.</p>
	<p>The triangle symbol indicates precautions (including warnings). The specific operation is shown in the triangle and explained in text. This example indicates a general precaution.</p>
	<p>The filled circle symbol indicates operations that you must do. The specific operation is shown in the circle and explained in text. This example shows a general precaution for something that you must do.</p>

## Warnings

### **WARNING**

#### Disassembly and Dropping

Do not attempt to disassemble, repair, or modify the product in any way. Doing so may result in malfunction or fire.



#### Installation

Always connect to a ground of 100  $\Omega$  or less when installing the product.



Ensure that installation and post-installation checks of the product are performed by personnel in charge who possess a thorough understanding of the machinery to be installed.



#### Fail-safe Measures

Provide safety measures in external circuits to ensure safety in the system if an abnormality occurs due to malfunction of the product or due to other external factors affecting operation. Not doing so may result in serious accidents due to incorrect operation.



Emergency stop circuits, interlock circuit, limit circuits, and similar safety measures must be provided in external control circuits.



Unintended behavior may occur when an error occurs in internal memory of the product. As a countermeasure for such problems, external safety measures must be provided to ensure safe operation of the system.



The use of an uninterruptible power supply (UPS) allows normal operation to continue even if a momentary power failure occurs, possibly resulting in the reception of an erroneous signal from an external device affected by the momentary power failure. Take external fail-safe measures. Where necessary, monitor the power supply voltage on the system for external devices and use it as an interlock condition.



Do not use the input functions of the touchscreen in applications that involve human life, in applications that may result in serious injury, or for emergency stop switches.



## Actual Operation

---

Security setting adjustments should only be performed by the engineer in charge that possesses a thorough understanding of the security settings. Selecting non-recommended security settings can put your system at risk.



Changing BIOS information is only allowed for the engineer in charge that possesses a thorough understanding of the BIOS settings because it can change the behavior of the product.



Water or other liquid present on the touchscreen surface may create false touch behavior and unexpected operation. Wipe away the liquid on the touchscreen before operation.



## Cybersecurity

---

To maintain the security and reliability of the system, a robust cybersecurity defense program should be implemented, which may include some or all of the following:

### Anti-virus protection

- Install the latest commercial-quality anti-virus software on the computer connected to the control system and keep the software and virus definitions up-to-date.
- Scan USB drives or other external storage devices before connecting them to control systems and equipment.

### Security measures to prevent unauthorized network access

- Install physical controls so that only authorized personnel can access control systems and equipment.
- Reduce connections to control systems and equipment via networks to prevent access from untrusted devices.
- Install firewalls to block unused communications ports and limit communication between systems. Limit access between control systems and systems from the IT network.
- Control remote access and adopt multifactor authentication to devices with remote access to control systems and equipment.
- Set strong password policies and monitor for compliance frequently.

### Data input and output protection

- Backup data and keep the data up-to-date periodically to prepare for data loss.
- Validate backups and retention policies to cope with unintentional modification of input/output data to control systems and equipment.
- Validate the scope of data protection regularly to accommodate changes.
- Check validity of backups by scheduling test restores to ensure successful recovery from incidents.
- Safety design, such as emergency shutdown and fail-soft operations in case of data tampering and incidents.

### Additional recommendations

- When using an external network environment to connect to an unauthorized terminal such as a SCADA, HMI or to an unauthorized server may result in network security issues such as spoofing and tampering.
- You must take sufficient measures such as restricting access to the terminal, using a terminal equipped with a secure function, and locking the installation area by yourself.
- When constructing network infrastructure, communication failure may occur due to cable disconnection or the influence of unauthorized network equipment.
- Take adequate measures, such as restricting physical access to network devices, by means such as locking the installation area.
- When using devices equipped with an SD Memory Card, there is a security risk that a third party may acquire, alter, or replace the files and data in the removable media by removing or unmounting the media.
- Please take sufficient measures, such as restricting physical access to the Controller or taking appropriate management measures for removable media, by means of locking and controlling access to the installation area.
- Educate employees to help them identify phishing scams received via email on systems that will connect to the control network.



## Cautions

# ⚠ CAUTION

### Installation

When installing or removing a PCIe card, avoid touching the sharp edges of the sheet metal frame tab. Injury may result.



### Wiring

The product has an internal non-isolated DC power supply. Circuit ground (0 VDC) and frame ground are connected together. When connecting a non-isolated device or a non-isolated interface to the product, take appropriate actions to avoid communication failures or damage to the mentioned ports.

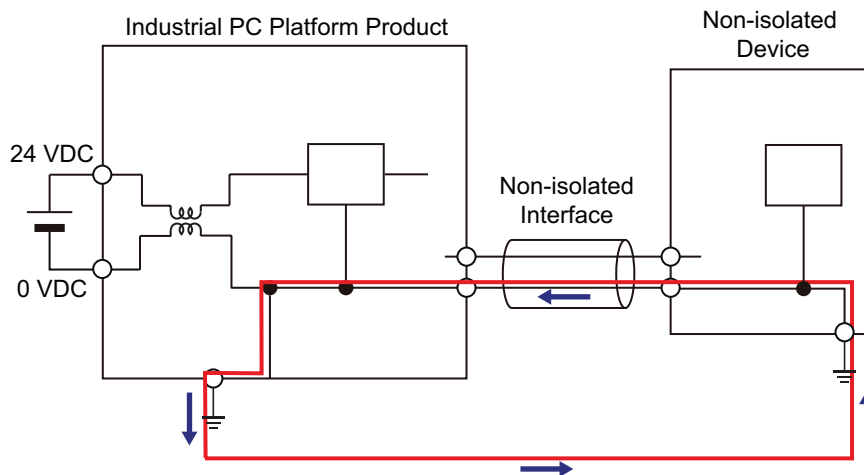

Never ground the 24 VDC side of the power supply. This may cause a short circuit.



### Actual Operation

When using a system with multiple touchscreens, multiple users can perform simultaneous operations. Make sure that this can not result in unintended actions.



# Precautions for Safe Use

## Disassembly, Dropping, Mounting, Installation and Storage

- Do not drop the product or subject it to abnormal vibration or shock. Doing so may result in product malfunction or burning.
- When unpacking, check carefully for any external scratches or other damages. Also, shake the product gently and check for any abnormal sound.
- Always use the devices specified in the relevant manual.
- The product must be installed in a control panel.
- Always install equipment that is included in the product specifications. Not doing so may result in failure or malfunction.
- Install the product in the correct orientation and temperature according to the specifications in the manual to prevent overheating. Not doing so may result in malfunction.
- When connecting peripheral devices to the product, ensure sufficient countermeasures against noise and static electricity during installation of the peripheral devices.
- Always use the CFast Card slot cover to fully insert the CFast Card. Attempting to fully insert the CFast Card using your finger can result in injury of your finger due to sharp edges around the CFast Card bay.
- The mounting panel must be between 1.6 and 6.0 mm thick. Tighten the Mounting Brackets evenly to a torque of 0.6 Nm to maintain water and dust resistance. If the tightening torque exceeds the specified value, or the tightening is not even, deformation of the front panel may occur. Additionally, make sure the panel is not dirty or warped and that it is strong enough to hold the product.
- Do not let metal particles enter the product when preparing the panel. Do not allow wire clippings, shavings, or other foreign material to enter any product. Otherwise, the product burning, failure, or malfunction may occur. Cover the product or take other suitable countermeasures, especially during wiring work.

## Wiring

- Follow the instructions in the manual to correctly perform connector wiring and insertion. Double-check all wiring and connector insertion before turning ON the power supply.
- Always ensure connectors, cables, PCIe Cards and Storage devices are completely locked in place to prevent accidental disconnection.
- Before you connect a computer to the product, disconnect the power supply plug of the computer from the AC outlet. Also, if the computer has an FG terminal, make the connections so that the FG terminal has the same electrical potential as the product. A difference in electrical potential between the computer and the product may cause failure or malfunction.
- Do not bend or pull the cables beyond normal limit. Do not place heavy objects on top of the cables or other wiring lines. Doing so may break the cables.
- Always use power supply wires with sufficient wire diameters to prevent voltage drop and burning. Make sure that the current capacity of the wire is sufficient. Otherwise, excessive heat may be generated. When cross-wiring terminals, the total current for all the terminals will flow in the wire. When wiring cross-overs, make sure that the current capacity of each of the wires is not exceeded.
- Be sure that all mounting bracket screws and cable connector screws are tightened to the torque specified in the relevant manuals. The loose screws may result in fire or malfunction.

- Use crimp terminals for wiring.
- For an NY Monitor Link connection, always follow the cable type and connection method specifications in the manual. Otherwise, communications may be faulty.

### Power Supply Design and Turning ON/OFF the Power Supply

- Always use a power supply that provides power within the rated range in the manual.
- Do not perform a dielectric strength test.
- Always use the recommended uninterruptible power supply (UPS) to prevent data loss and other system file integrity issues caused by unexpected power interruption. Back up the system files in the planned way to prevent data loss and other system file integrity issues caused by incorrect operation.
- Use an Omron S8BA UPS with the correct revision number to prevent improper system shutdown.
- Power ON after connecting the product and an external monitor.
- Always check the power supply and power connections before applying power. Incorrect power connections can damage the product or cause burning.
- Always turn OFF the power supply to system before you attempt any of the following.
  - Inserting or removing PCIe Cards
  - Connecting cables
  - Connecting or disconnecting the connectors
  - Wiring the system
  - Replacing or removing the storage device
  - Replacing the Battery
  - Replacing the Fan Unit
- Do not turn ON the power supply to the product when a part of a human body or a conductive object is touching the surface of the touchscreen. Doing so will cause the touchscreen functionality to be disabled. Remove the conductive object and cycle the power supply to restore the touchscreen functionality.

### Actual Operation

- Choose a OS password that is not obvious to prevent unauthorized access.
- Remember the OS user name and password. The product is inaccessible without it.
- Before operating the system, please make sure the appropriate software is installed and configured. Doing so may prevent unexpected operation.
- Install all updates and ensure the browser stays up-to-date.
- Install all updates and ensure the firewall stays up-to-date.
- Install all updates and ensure virus definitions stay up-to-date.
- Make sure that your OS environment is protected against malicious software and viruses.
- Do not remove the fan cover while the power is ON. Contact with a rotating fan may result in injury.
- Virtual memory settings can affect the performance of the system. Disable the paging file after installation of applications or updates.
- Correctly perform wiring and setting, and ensure that the shutdown by the UPS can be executed.
- Always use the SMART monitoring feature for storage devices that do not comply to the Omron Storage Device Specifications. Monitor the operating temperature and vibrations to ensure they stay within the environmental specifications of the storage device.

## Operation

- Do not carry out the following operations when accessing a USB device or an SD Memory Card.
  - Turn OFF the power supply of the product.
  - Press the Power Button of the product.
  - Remove a USB device or an SD memory card.
- Do not attempt to remove or touch the fan unit while the product is powered ON or immediately after the power supply is turned OFF. If you attempt to replace the fan unit then, there is a risk of personal injury due to hot or rotating parts.
- Press the power button for several seconds to force the product shutdown. Always back up files in the planned way to prevent data loss or system file corruption.
- Do not touch any product housing when power is being supplied or immediately after the power supply is turned OFF. Doing so may result in burn injury.
- Confirm the safety of the system before using the touch panel.
- Signals from the touchscreen may not be entered if the touchscreen is pressed consecutively at high speed. Only move on to the next operation after confirming that the product has detected the previous input of the touchscreen.
- Do not accidentally press the touchscreen when the backlight is not lit or when the display does not appear. Confirm the safety of the system before pressing the touchscreen.
- Do not use hard or pointed objects to operate or scrub the touchscreen, otherwise the surface of the touchscreen may be damaged.
- In systems with multiple screens in extended view, an interruption in the video signal of one screen will cause all windows on that screen to be moved to the primary screen. Make sure that this situation is properly handled.

## General Communications

- Separate the machine network segment from the office network to avoid communication failures.

## Battery and Fan Replacement

Applicable for products with a cooling layer that has a removable cover.

- Dispose of any Battery that has been dropped on the floor or otherwise subjected to excessive shock. Batteries that have been subjected to shock may leak if they are used.
- UL standards require that only an experienced engineer replace the Battery. Make sure that an experienced engineer is in charge of Battery replacement.
- The Battery may leak, rupture, heat, or ignite. Never short-circuit, charge, disassemble, heat, or incinerate the Battery or subject it to strong shock.
- If the storage period exceeds 6 months, check the performance of the fan unit before production starts.

## Cleaning, Maintenance and Disposal

- Do not use corrosive substances to clean the product. Doing so may result in the failure or malfunction.
- Periodically check the installation conditions in applications where the product is subject to contact with oil or water.
- As the rubber gasket will deteriorate, shrink, or harden depending on the operating environment, periodical inspection is necessary.
- Dispose of the product and batteries according to local ordinances as they apply.



廢電池請回收

- Dispose in accordance with applicable regulations.



- The following information must be displayed for all products that contain primary lithium batteries with a perchlorate content of 6 ppb or higher when shipped to or transported through the State of California, USA.
  - Perchlorate Material - special handling may apply.
  - See <http://www.dtsc.ca.gov/hazardouswaste/perchlorate>.
- The product contains a lithium battery with a perchlorate content of 6ppb or higher. When exporting an end product containing the product to or shipping through California, USA, label all packing and shipping containers appropriately.

## VESA Mount Bracket

The VESA Mount Bracket is optional hardware to mount an OMRON Industrial Monitor or Industrial Panel PC.

- Always use an arm construction with sufficient strength to support the Industrial Monitor or Panel PC and the additional forces from making adjustments. Not doing so may lead to system damage or injury.
- Carefully follow the instructions in the manual when mounting or dismounting a unit from the VESA mount bracket, to avoid system damage or injury.
- Check the reliability of the mechanical construction of arm and VESA mount bracket on a regular basis. Doing so will prevent unexpected breakdown of the construction, which might lead to system damage or injury.

# Precautions for Correct Use

## Storage, Installation and Mounting

- Do not operate or store the product in the following locations. Operation may stop or malfunctions may occur.
  - Locations subject to direct sunlight
  - Locations subject to temperatures or humidity outside the range specified in the specifications
  - Locations subject to condensation as the result of severe changes in temperature
  - Locations subject to corrosive or flammable gases
  - Locations subject to dust (especially iron dust) or salts
  - Locations subject to exposure to water, oil or chemicals
  - Locations subject to shock or vibration
  - Locations outdoors subject to direct wind and rain
  - Locations subject to strong ultraviolet light
- Always install the product with sufficient surrounding space to allow for adequate heat dissipation and cooling effect.
- Take appropriate and sufficient countermeasures when installing the product in the following locations
  - Locations subject to strong, high-frequency noise
  - Locations subject to static electricity or other forms of noise
  - Locations subject to strong electromagnetic fields
  - Locations subject to possible exposure to radioactivity
  - Locations close to power lines
- Always touch a grounded piece of metal to discharge static electricity from your body before starting an installation or maintenance procedure.
- Insert USB devices and PCIe devices correctly to avoid the burning, failure or malfunction.
- Execute a backup of the product before PCIe addition or replacement. Be sure that the PCIe device works correctly before you use them for actual operation. PCIe devices and their related software may cause an OS boot failure or crash.
- The backlight has a finite life and if that is exceeded, the product may fail or malfunction. Check the brightness periodically and if necessary, replace the product.
- Ensure the selected operating system supports ACPI to enable operating system shutdown using the power button.
- Download the enhanced Video Driver from the OMRON Download Center and install it on the Industrial PC.

## Wiring

- Always ensure the rated supply voltage is connected to the product.
- Do not allow wire clippings, shavings, or other foreign material to enter the product. Otherwise, burning, failure, or malfunction may occur. Cover the product or take other suitable countermeasures, especially during wiring work.
- Do not use cables exceeding the maximum specified length. Doing so may cause malfunction.
- Do not connect an AC power supply to the DC power connector.
- Observe the following precautions to prevent broken wires.

- When you remove the sheath, be careful not to damage the conductor.
- Connect the conductor without twisting the wires.
- Do not weld the conductors. Doing so may cause the wires to break with vibration.

## Actual Operation and Operation

- After an OS update or a peripheral device driver update for the product is executed, the product behavior might be different. Confirm that operation is correct before you start actual operation.
- Always create a Windows System Repair Disk using Windows Backup and Restore to recover the HDD/SSD configuration if necessary.
- Ensure the fan is operational to provide adequate cooling while the power is turned ON.
- Storage devices, SD Memory Cards, power buttons, fan units and batteries have finite lives and if those are exceeded, the product may fail or malfunction.
- Always monitor the fan status. If a fan is used beyond its service life, the *Low Revolution Speed* warning message is displayed and the product overheating may occur.
- Always monitor the battery warning message. When a battery has low voltage, the system time will be lost.
- Do not reset or power OFF the product while the password is being changed. If you fail to save the password there is a possibility that the project will not work.
- The touchscreen supports 5 simultaneous touches. When the number of touches is exceeded, not all touch points will be detected.
- The capacitive touchscreen reacts to contact on its surface. Accidental touching the surface of the touchscreen may cause unintended behavior.
- You can operate the touchscreen even when you wear some gloves. Confirm that you can correctly operate the touchscreen while wearing gloves prior to actual operation.
- Do not turn ON the power supply to the product when a part of a human body or a conductive object is touching the surface of the touchscreen. Doing so will cause the touchscreen functionality to be disabled. Remove the conductive object and cycle the power supply to restore the touchscreen functionality.
- If the product experiences a sudden loss of power or disconnecting the cable while saving a setting or transfer of data is underway, the changes may not be stored and unexpected behavior may occur.
- Ensure that available software checks are performed by personnel in charge who possess a thorough understanding of the software.
- Diagnostic information is not available when the Industrial PC Support Utility is not installed.

## Battery Replacement

Applicable for products with a cooling layer that has a removable cover.

- Turn ON the power after replacing the battery for a product that has been unused for an extended period of time. Leaving the product unused without turning ON the power even once after the battery is replaced may result in a shorter battery life.
- Make sure to use a battery of the correct type, install the battery properly.
- Apply power for at least five minutes before changing the battery. Mount a new battery within five minutes after turning OFF the power supply. If power is not supplied for at least five minutes, the clock data may be lost. Check the clock data after changing the battery.

## SD Memory Cards

- Insert an SD Memory Card completely and ensure it is in place.

## Cleaning and Maintenance

- Do not use corrosive substances to clean the product.
- Turn OFF the product or disable the touchscreen for cleaning with water.

## VESA Mount Bracket

The VESA Mount Bracket is optional hardware to mount an OMRON Industrial Monitor or Industrial Panel PC.

- Mounting a Panel PC on an arm construction may increase movements and vibrations. Be aware that this can have a negative impact on HDD reliability and life. Preferably use SSD storage in combination with a mechanical arm construction.
- When adjusting the position of a Panel PC arm, avoid touching the heatsink at the rear. High CPU loads can cause the heatsink to become hot, which could result in burn injury when the heatsink is touched.
- Make sure to select the correct VESA mount bracket model for your Industrial Monitor or Panel PC. Using an incorrect bracket model will result in an unreliable mechanical construction which might lead to system damage or injury.
- Do not cover the openings of the VESA mount bracket. The purpose of the openings is to provide proper cooling of your Industrial Monitor or Panel PC. Closing them could adversely affect unit performance and life.
- Always fix cables to the VESA mount bracket with cable ties to prevent unexpected disconnection.
- Please be aware that shocks or vibrations of the arm construction may interfere with accurate touchscreen operations.
- Do not suspend other objects to the arm and bracket construction. Doing so may cause the construction to fail, leading to system damage or injury.

# Regulations and Standards

---

## Conformance to EU Directives

The Industrial Panel PC complies with EU Directives. To ensure that the machine or device in which the Panel PC is used complies with EU Directives, the following precautions must be observed:

- The Panel PC must be installed within a control panel.
- The Panel PC that complies with EU Directives also conforms to the Common Emission Standard. Radiated emission characteristics may vary depending on the configuration of the control panel used, other devices connected to the control panel, wiring, and other conditions. You must therefore confirm that the overall machine or equipment in which the Panel PC is used complies with EU Directives.
- This is a Class A product (for industrial environments). In a residential environment, it may cause radio interference. If radio interference occurs, the user may be required to take appropriate measures.

## Applicable Directive

---

EMC Directive

## EMC Directive

---

OMRON devices that comply with EU Directives also conform to the related EMC standards so that they can be more easily built into other devices or the overall machine. The actual products have been checked for conformity to EMC standards.

Applicable EMC (Electromagnetic Compatibility) standards are as follows:

- EMS (Electromagnetic Susceptibility): EN 61131-2
- EMI (Electromagnetic Interference): EN 61131-2

Whether the products conform to the standards in the system used by the customer, however, must be checked by the customer. EMC-related performance of the OMRON devices that comply with EU Directives will vary depending on the configuration, wiring, and other conditions of the equipment or control panel on which the OMRON devices are installed. The customer must, therefore, perform the final check to confirm that devices and the overall machine conform to EMC standards.

## Conformance to KC Certification

When you use this product in South Korea, observe the following precautions.

### 사 용 자 안 내 문

이 기기는 업무용 환경에서 사용할 목적으로 적합성평가를 받은 기기로서 가정용 환경에서 사용하는 경우 전파간섭의 우려가 있습니다.

This product meets the electromagnetic compatibility requirements for business use. There is a risk of radio interference when this product is used in home.

## Conformance to UL and CSA Standards

Some Industrial PC Platform products comply with UL and CSA standards. If you use a product that complies with UL or CSA standards and must apply those standards to your machinery or devices, refer to this manual. This manual provides the application conditions for complying with the standards. If the product is used in a manner not specified in the Instruction Sheet or in the product manuals then the protection provided by the equipment may be impaired.

## Software Licenses and Copyrights

This product incorporates certain third party software. The license and copyright information associated with this software is available at [https://www.fa.omron.co.jp/nj\\_info\\_e/](https://www.fa.omron.co.jp/nj_info_e/).

# Related Manuals

The following manuals are related. Use these manuals for reference.

## Related Panel PC Manual

Manual name	Cat. No.	Model-ID	Application	Description
NY-series Operating Systems and Software Utilities Manual	W616	NYB NYP	Learning all software related information about the Industrial Panel PC. This includes introductory information, installation, operating procedures and maintenance. Mainly software information is provided.	An introduction to the Panel PC is provided along with the following information: <ul style="list-style-type: none"> <li>• Overview</li> <li>• Software</li> <li>• Specifications</li> <li>• Installation</li> <li>• Operating Procedures</li> <li>• Maintenance</li> </ul>

## Related Products Manuals

Manual name	Cat. No.	Model-ID	Application	Description
UPS S8BA User's Manual	U702	S8BA	Learning the information that is necessary to use the Uninterruptible Power Supply (UPS) Unit.	An introduction to the UPS is provided along with the following information: <ul style="list-style-type: none"> <li>• Overview</li> <li>• Preparation</li> <li>• Installation and Connection</li> <li>• Check and Start Operation</li> <li>• Maintenance and Inspection</li> <li>• Shutdown Processing</li> <li>• I/O Signal Functions</li> <li>• Troubleshooting</li> </ul>
UPS Setting Utility Instruction Manual	---	<ul style="list-style-type: none"> <li>• SB8A</li> <li>• BU-2RWL</li> </ul>	Learning the information that is necessary to connect the UPS and to configure all settings.	An introduction to the UPS Setting Utility is provided along with the following information: <ul style="list-style-type: none"> <li>• Overview</li> <li>• Operating Environment</li> <li>• Software License Agreement</li> <li>• Connect</li> <li>• Use the UPS Setting Utility</li> <li>• Setting Details</li> </ul>

## Industrial Monitor Manual

This table contains the related manual of the Industrial Monitor.

Manual name	Cat. No.	Model-ID	Application	Description
Industrial Monitor User's Manual	W554	NYM12W-C1□□□ NYM15W-C1□□□ NYM19W-C1□□□	Learning all basic information about the Industrial Monitor. This includes introductory information with features, hardware overview, specifications, mounting, wiring, connecting, operating and maintaining the Industrial Monitor.	An introduction to the Industrial Monitor is provided along with the following information: <ul style="list-style-type: none"> <li>• Overview</li> <li>• Hardware</li> <li>• Software</li> <li>• Specifications</li> <li>• Installation</li> <li>• Operating Procedures</li> <li>• Maintenance</li> </ul>

# Terminology and Abbreviations

## Industrial PC Platform

Term / Abbreviation	Description
Industrial PC Platform	An integrated range of OMRON products designed for use in any industrial application that will benefit from advanced PC technology
Industrial Monitor	An industrial monitor with a touchscreen as the user interface designed to work in industrial environments
Industrial Panel PC	An industrial PC with an integrated touchscreen monitor designed to work in industrial environments
Industrial Box PC	A box-shaped industrial PC including an OS designed to work in industrial environments
IPC	Industrial PC
Industrial Pharmaceutical Monitor	An industrial monitor with a touchscreen as the user interface designed to work in pharmaceutical environments.
Sysmac	OMRON's brand name of the product family for the industrial automation equipment

## Hardware

Term / Abbreviation	Description
3D TLC	3D Triple-Level Cell flash memory
BMC	Board Management Controller
CFast	An SSD CFast storage device
CPU	A Central Processing Unit is the hardware within a computer that executes the instructions of a computer program
DVI	Digital Visual Interface
DVI-D	A Digital Visual Interface with only Digital signals
DVI-I	A Digital Visual Interface with Analog and Digital signals
Ethernet	A network communication protocol used in TCP/IP network
HDD	A Hard Disk Drive storage device
HMI	A Human Machine Interface that facilitates machine operation and control
MLC	Multi-Level Cell type of SSD storage device
NYML	NY Monitor Link interface with video signals and USB signals
PCIe	The PCI Express is a high-speed computer bus standard called Peripheral Component Interconnect Express
PoE	Power over Ethernet
pSLC	Pseudo Single Level Cell type of SSD storage device
SATA	The Serial AT Attachment is a serial bus interface primarily used with mass storage devices such as hard disk drives
SLC	Single-Level Cell type of SSD storage device
SO-DIMM	Small Outline Dual Inline Memory Module
SSD	A Solid State Drive storage device
USB	Universal Serial Bus

## Software

Term / Abbreviation	Description
ACPI	Advanced Configuration and Power Interface protocol for operating systems
API	Application Programming Interface
BIOS	Basic Input Output System. The first software run by a PC when powered on.
Developer	Any person involved with the development of software
DST	Daylight Saving Time
EFW	Enhanced Write Filter
FBWF	File-Based Write Filter
IIoT	Industrial Internet of Things
Linux	An open source Operating System
MBR	Master Boot Record
Merge module	A module providing a standard method by which developers deliver shared Windows installer components and setup logic to their applications
MSDN	Microsoft Developer Network
NUI	Natural User Interface
OS	Operating System
PLC	Programmable Logic Controller
RTOS	Realtime Operating System
SDK	Software Development Kit
TCP/IP	Transmission Control Protocol / Internet Protocol, a core member of the Internet protocol suite
TPM	Trusted Platform Module
Windows	An Operating System designed by Microsoft

# Revision History

A manual revision code appears as a suffix to the catalog number on the front and back covers of the manual.

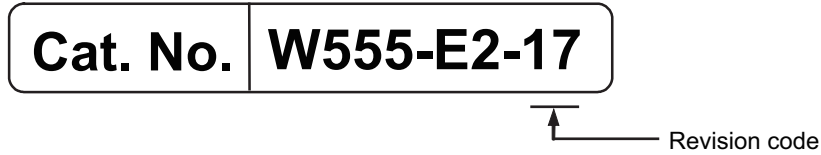

Revision code	Date	Revised content
17	November 2025	<ul style="list-style-type: none"> <li>Added Windows 11</li> <li>Minor modifications</li> </ul>
16	July 2024	<ul style="list-style-type: none"> <li>Added CPU types               <ul style="list-style-type: none"> <li>Intel® Core™ i7-1185GRE</li> <li>Intel® Core™ i5-1145GRE</li> </ul> </li> <li>Improved NY Monitor Link Cable details</li> <li>Minor modifications</li> </ul>
15	September 2023	Minor modifications
14	June 2023	<ul style="list-style-type: none"> <li>Added CPU types               <ul style="list-style-type: none"> <li>Intel® Core™ i5-1145GRE</li> <li>Intel® Core™ i3-1115GRE</li> <li>Intel® Atom® x6425RE</li> </ul> </li> <li>Added SSDs               <ul style="list-style-type: none"> <li>128, 256, 512 GB 3D TLC</li> <li>1TB 3D TLC SSD</li> <li>128, 256, 512 GB CFAST</li> </ul> </li> <li>Added/Replaced DDR4 Memory               <ul style="list-style-type: none"> <li>4, 8, 16, 32, 64, 96 GB Non-ECC</li> <li>32, 64, 96 GB ECC</li> </ul> </li> <li>Added DisplayPort</li> <li>Restructured temperature specifications</li> <li>Minor modifications</li> </ul>
13	December 2021	<ul style="list-style-type: none"> <li>Added VESA mount information</li> <li>Added image retention information</li> <li>Minor modifications</li> </ul>
12	April 2021	Updated BIOS details for <ul style="list-style-type: none"> <li>Intel® Core™ i5-7300U</li> <li>Intel® Celeron® 3965U</li> </ul>
11	November 2020	<ul style="list-style-type: none"> <li>Added Intel® Core™ i7-7820EQ CPU</li> <li>Minor modifications</li> </ul>
10	July 2020	<ul style="list-style-type: none"> <li>Added SSD 256 GB NY000-AS08</li> <li>Added Overall Setup Procedure</li> <li>Minor modifications</li> </ul>
09	July 2019	Updated Conformance to KC certification

Revision code	Date	Revised content
08	May 2019	<ul style="list-style-type: none"> <li>• Separated software information to a new manual NY-series Operating Systems and Software Utilities Manual (Cat. No. W616)</li> <li>• Added Intel® Atom® x5-E3930 CPU</li> <li>• Added 19" monitor</li> <li>• Minor modifications</li> </ul>
07	May 2018	<ul style="list-style-type: none"> <li>• Added main memory DDR4 32 GB</li> <li>• Added main memory DDR4 ECC 8 GB and 16 GB</li> <li>• Added SSD 500 GB NY000-AS05</li> <li>• Added CFast 64 GB NY000-AT00, 128 GB NY000-AT01, 256 GB NY000-AT02</li> <li>• Added RJ45 Gb Ethernet option</li> <li>• Minor modifications</li> </ul>
06	April 2018	<ul style="list-style-type: none"> <li>• Added layer information</li> <li>• Added thin cooling layer</li> <li>• Added Intel® Core™ i5-7300U CPU</li> <li>• Added Intel® Celeron® 3965U CPU</li> <li>• Added SSD 64 GB NY000-AS03</li> <li>• Added SSD 128 GB NY000-AS04</li> <li>• Added main memory DDR4 4 GB and 8 GB</li> <li>• Updated Power Consumption Specifications</li> <li>• Implemented new location for the product code of an operating system</li> </ul>
05	January 2018	<ul style="list-style-type: none"> <li>• Added option for 16 GB main memory</li> <li>• Added options for 500 GB and 1 TB HDD</li> <li>• Added support of software RAID</li> <li>• Minor modifications</li> </ul>
04	June 2017	Added NY Monitor Link option
03	May 2017	<ul style="list-style-type: none"> <li>• Added operating system Windows 10 IoT Enterprise LTSC</li> <li>• Added Storage Device Considerations</li> <li>• Modified UPS configuration procedure</li> <li>• Minor modifications</li> </ul>
02	December 2016	<ul style="list-style-type: none"> <li>• UL implementation</li> <li>• KC Standard implementation</li> <li>• Minor modifications</li> </ul>
01	August 2016	



# 1

## Overview

This section provides general information about the Industrial Panel PC.

---

<b>1-1</b>	<b>Intended Use .....</b>	<b>1-2</b>
<b>1-2</b>	<b>Hardware Features .....</b>	<b>1-3</b>
<b>1-3</b>	<b>ID Information Label.....</b>	<b>1-4</b>
<b>1-4</b>	<b>Product Configuration Panel PC.....</b>	<b>1-5</b>
<b>1-5</b>	<b>Overall Setup Procedure .....</b>	<b>1-7</b>
<b>1-6</b>	<b>Industrial PC Platform Overview .....</b>	<b>1-8</b>
1-6-1	Industrial Monitor .....	1-9
1-6-2	Industrial Box PC .....	1-10
1-6-3	Industrial Panel PC .....	1-10

# 1-1 Intended Use

---

The Industrial Panel PC is intended to be used as a panel mounted industrial PC in factory automation environments. This Panel PC can be used with an Operating System and third party software to serve as a powerful PC platform.

A user can access the Panel PC for control, configuration and supervisory operations using the integrated touchscreen display.

The Panel PC can easily be integrated in manufacturing innovations like big data, NUI and IIoT.

The Panel PC has a compact design that offers flexibility, expandability and easy maintenance for applications in factory automation environments.

## 1-2 Hardware Features

---

The Industrial Panel PC provides the following hardware features.

- Flexible mounting orientation  
The Panel PC is designed to support landscape and portrait mounting orientations.
- Powerful CPU options  
Powerful CPU options provide high performance for various applications.
- Fanless cooling for multiple CPU types  
The Panel PC has passive cooling for multiple CPU types which means no moving parts and less maintenance effort.
- Easy access to storage devices and the PCI Express Card  
Adding or changing storage devices (HDD, SSD) and the PCI Express Card is fast and simple.
- RAID support
- LED indicators  
LED indicators provide a clear indication of the operational status of the Panel PC.
- Video interfaces  
The video interface for the Panel PC is provided with a DisplayPort or DVI connector for connection to an additional monitor.  
An extra (optional) video interface is available for connection to a second additional monitor.
- NY Monitor Link interface  
The interface combines video signals and USB signals for a connection to an OMRON Industrial Monitor using a single NY Monitor Link cable up to 100 meter.
- 3 Ethernet ports  
Interface with multiple networks. An optional 4<sup>th</sup> Ethernet port can be added.
- Built-in I/O  
Built-in I/O for UPS status and Panel PC shutdown control are provided.
- 4 USB ports  
4 USB-A ports are provided for connection to external USB devices such as keyboards, memory sticks, or other peripheral hardware.
- SD Memory Card slot  
An SD Memory Card slot can be provided for removable memory.
- CFast Card slot  
A CFast Card slot can be provided as a removable storage device.
- LCD touchscreen  
The LCD touchscreen provides high functionality for your PC interface.  
The high resolution and a high brightness provide clarity and high visibility.
- Multi-touch functionality  
Up to 5 simultaneous touches are supported for complex functions.
- Backlit Logo  
The standard product logo is OMRON. Check your sales representative for the possibilities to customize the product logo. The product logo is provided with a controllable backlight to increase visibility.
- Brightness control  
Use the Monitor Utilities to control the Panel PC's LCD brightness.

## 1-3 ID Information Label

The ID information label contains relevant information about the Industrial Panel PC. The following example will be different from your product label.

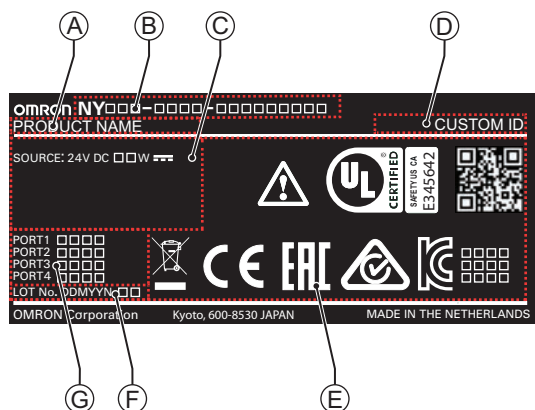

Item	Name	Description
A	Product name	The name of your product
B	Model *1	Model and configuration details
C	Power rating	Power rating details and optional UL related information
D	Custom ID (Optional)	A custom ID [NYC□□□□-□□□□□□□□] Only applicable for customized IPC platform products.
E	Standards and QR code	The applicable standards and a QR code for OMRON internal use.
F	LOT number and serial number	Production details, consisting of: <ul style="list-style-type: none"> <li>The lot number of the Industrial Panel PC in the format DDMYY□. DDMYY with Month number 1 to 9 for January to September, X for October, Y for November, and Z for December.</li> <li>□: For use by OMRON</li> <li>Serial number (4 digits)</li> </ul>
G	MAC ADDRESS *2	<ul style="list-style-type: none"> <li>PORT 1: the MAC address of Ethernet port 1</li> <li>PORT 2: the MAC address of Ethernet port 2</li> <li>PORT 3: the MAC address of Ethernet port 3</li> <li>PORT 4: the MAC address of Ethernet port 4 (Optional)</li> </ul>

\*1. Refer to 1-4 Product Configuration Panel PC on page 1-5 for model details.

\*2. Refer to 4-2-4 Ethernet Connector Specifications on page 4-33 for Ethernet specifications.



### Additional Information

Refer to 3-1-2 Base Layer on page 3-5 for the ID label location.

## 1-4 Product Configuration Panel PC

This section provides an overview of the product configurations available for the Industrial Panel PC. The product configuration is visible in the model-ID that is mentioned on the ID information label of the Panel PC.

The structure of the model-ID is: NYP□□-□□□□□-□□□□□□□□.

Each item in the model-ID has a specific meaning.

N	Y	P	□	□	-	□	□	□	□	-	□	□	□	□	□	□	□	
1	2	3	4	5	6	7	8	9	10	11	12	13	14					

Item	Description	Option / Description
1	Series name	NYP: NY- series Industrial Panel PC
2	Processor	Intel Atom CPUs 2A: Intel® Atom® x5-E3940 3A: Intel® Atom® x6425RE  4 <sup>th</sup> generation CPUs 17: Intel® Core™ i7-4700EQ, active cooling 1C: Intel® Celeron® 2980U 25: Intel® Core™ i5-4300U  7 <sup>th</sup> generation CPUs 2C: Intel® Celeron® 3965U 27: Intel® Core™ i7-7820EQ, active cooling 35: Intel® Core™ i5-7300U  11 <sup>th</sup> generation CPUs 13: Intel® Core™ i3-1115GRE 37: Intel® Core™ i7-1185GRE, active cooling 55: Intel® Core™ i5-1145GRE, active cooling 65: Intel® Core™ i5-1145GRE
3	Main memory	1: 2 GB, non-ECC 2: 4 GB, non-ECC 3: 8 GB, non-ECC 4: 16 GB, non-ECC 5: 32 GB, non-ECC 6: 64 GB, non-ECC 7: 96 GB, non-ECC C: 8 GB, ECC D: 16 GB, ECC E: 32 GB, ECC F: 64 GB, ECC G: 96 GB, ECC
4	Expansion slots	0: None 1: 1 PCIe slot

Item	Description	Option / Description
5	Operating system	0: No Operating System 1: Windows Embedded Standard 7 - 32 bit 2: Windows Embedded Standard 7 - 64 bit 3: Windows 10 IoT Enterprise 2016 LTSB - 64 bit 4: Windows 10 IoT Enterprise 2019 LTSC - 64 bit 5: Windows 10 IoT Enterprise 2021 LTSC - 64 bit 6: Windows 11 IoT Enterprise 2024 LTSC - 64 bit
6	Storage	0: None 1: 128 GB, CFast, 3D TLC 2: 256 GB, CFast, 3D TLC 3: 512 GB, CFast, 3D TLC 5: 64 GB, CFast MLC 6: 128 GB, CFast MLC 7: 256 GB, CFast MLC 8: 32 GB, SSD SLC 9: 64 GB, SSD SLC C: 320 GB, HDD D: 500 GB, HDD E: 1 TB, HDD F: 128 GB, SSD, 3D TLC G: 256 GB, SSD, 3D TLC H: 512 GB, SSD, 3D TLC K: 128 GB, SSD MLC L: 256 GB, SSD MLC M: 500 GB, SSD MLC P: 1 TB, SSD 3DTLC
7	Optional interface	0: None 1: RS-232C 2: DVI-D 4: DisplayPort 6: NY Monitor Link 9: Gb Ethernet
8	Display size (diagonal)	12: 12.1 inch model, 1280 x 800 pixels, 24 bit full color 15: 15.4 inch model, 1280 x 800 pixels, 24 bit full color 19: 18.5 inch model, 1920 x 1080 pixels, 24 bit full color
9	Display ratio	W: Wide
10	Touchscreen	C: Projected Capacitive Touch type
11	Frame type	1: Panel mounted
12	Material finish	0: Aluminum, painted black 1: Aluminum, Nickel plated
13	Built-in options	0: None
14	Logo	0: OMRON 2: Customization

# 1-5 Overall Setup Procedure

This section gives the overall setup procedure for the Industrial PC.

This manual presents this information in the same order as the following setup procedure.

To setup the Industrial PC:

- 1** Familiarize yourself with the Industrial PC
  - Refer to the information in this manual.  
Specifically refer to following sections of this manual:
    - *Section 2 System Configurations* on page 2-1
    - *Section 3 Hardware* on page 3-1
    - *Section 4 Specifications* on page 4-1
  - Refer to the information in related manual *NY-series Operating Systems and Software Utilities Manual (Cat. No. W616)*.
  
- 2** Install the IPC Hardware

Perform the procedures that are required to use the Industrial PC such as installation, and connection with peripheral devices including a UPS.  
Refer to *Section 5 Installation* on page 5-1.
  
- 3** Setup the IPC

Install and configure the operating system, the software support utilities and the UPS software.  
Refer to the information in related manual *NY-series Operating Systems and Software Utilities Manual (Cat. No. W616)*.
  
- 4** Operate the IPC

Use the operating procedures to operate the Industrial PC.  
Refer to:
  - *Section 6 Operating Procedures* on page 6-1
  - "Section Operating Procedures" in related manual *NY-series Operating Systems and Software Utilities Manual (Cat. No. W616)*

The setup of the Industrial PC is finished.

The section 'Maintenance' contains preventive and corrective maintenance information.

Refer to:

- *Section 7 Maintenance* on page 7-1
- "Section Maintenance" in related manual *NY-series Operating Systems and Software Utilities Manual (Cat. No. W616)*

## 1-6 Industrial PC Platform Overview

---

The Industrial PC Platform is an integrated range of products designed for use in a variety of industrial applications that will benefit from advanced PC technology. The range is scalable, robust and reliable, and is suitable for use with both standard operating system software and proprietary programs for machine control and automation.

In line with OMRON's established quality standards, each element in the Industrial PC Platform, ranging from the standalone Industrial Box PC to the touchscreen Industrial Monitor, is engineered with long-life components and built to the most advanced design standards.

The following sections introduce Industrial PC Platform products.

## 1-6-1 Industrial Monitor

The Industrial Monitor is of key importance at the interface between operator and system. The Industrial Monitor is efficient, effective and highly visible with an attractive design.

Using smart algorithms, the touch controller determines the exact location of each touch for precise control as well as detecting abnormal or illegal actions to protect misuse or false touches.



Industrial Monitor



Industrial Hygienic Monitor



Industrial Pharmaceutical Monitor

## 1-6-2 Industrial Box PC

The Industrial Box PC is designed to meet the specific needs of the industrial environment. Design simplification and future-proof architecture minimize the risk of failure. In addition, new PC features can be seamlessly incorporated, without the need for wholesale redesign. Examples are IPCs with a Machine Controller or IPCs designed specifically for an Autonomous Mobile Robot (AMR).



## 1-6-3 Industrial Panel PC

The Industrial Panel PC intelligently combines the functionality of the Industrial Box PC and Industrial Monitor. No cables are used between the two components, which ensures optimal signal distribution and reliable operation in industrial environments.

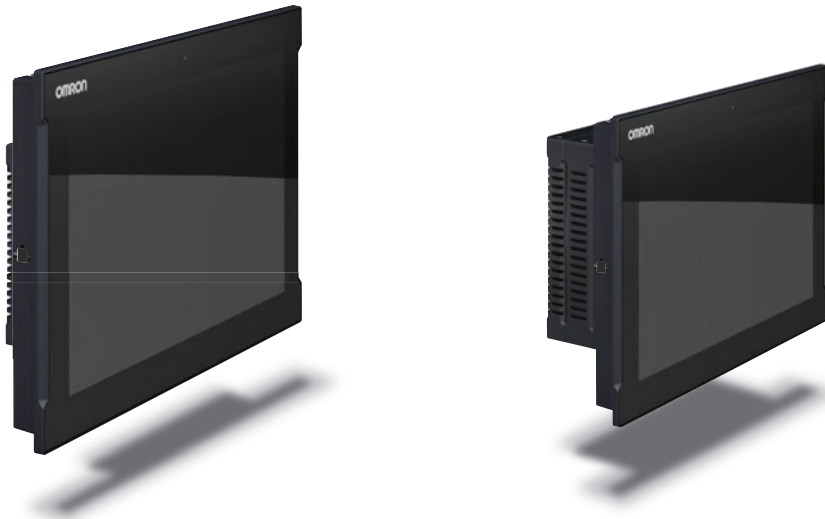



# System Configurations

This section provides an overview of the system configurations for the Industrial Panel PC.

---

2-1 Configuration for NYB and NYP..... 2-2

## 2-1 Configuration for NYB and NYP

The Industrial PC supports many different hardware configurations.

Refer to *1-4 Product Configuration Panel PC* on page 1-5 for more information.

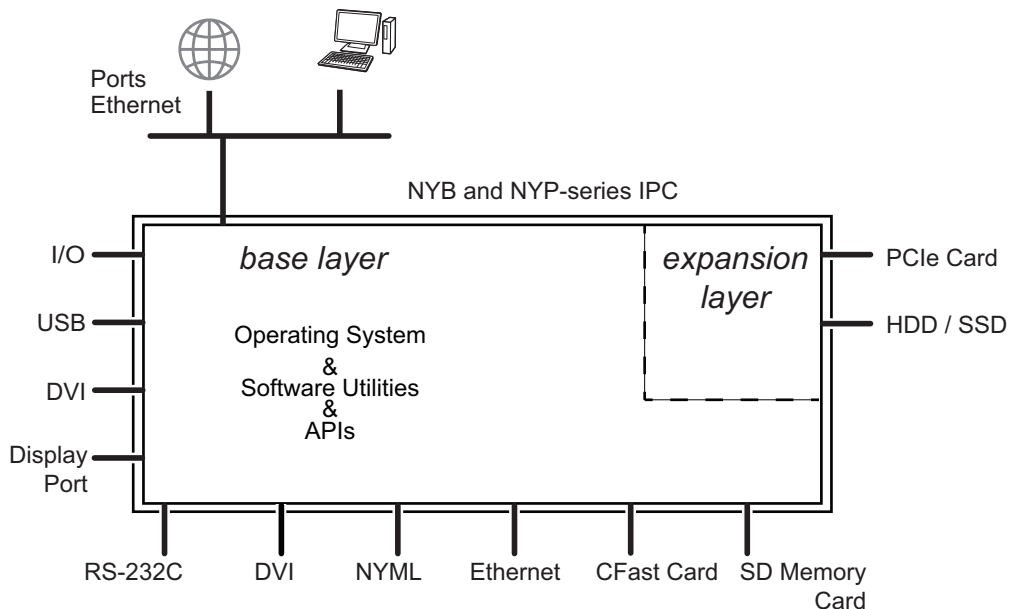

The major parts for configurations are layers.

- All configurations have the base layer and a cooling layer.  
The base layer contains the CPU, the software and most of the connectors and functionality.
- The optional expansion layer supports PCIe cards and storage devices.
- A display layer is always present for an Industrial Panel PC.



### Additional Information

- Refer to *3-1 Layers and Components* on page 3-3 for details.
- Refer to *NY-series Operating Systems and Software Utilities Manual (Cat. No. W616)* for details on the operating system, the support software and the APIs.

# 3

## Hardware

This section provides an overview of the hardware of the Industrial Panel PC.

---

<b>3-1</b>	<b>Layers and Components .....</b>	<b>3-3</b>
3-1-1	Cooling Layer .....	3-4
3-1-2	Base Layer .....	3-5
3-1-3	Expansion Layer (Optional) .....	3-6
3-1-4	Display Layer .....	3-7
<b>3-2</b>	<b>LED Indicators .....</b>	<b>3-8</b>
3-2-1	LED Indicators Display Layer .....	3-8
3-2-2	LED Indicators Base Layer .....	3-10
<b>3-3</b>	<b>Power Button .....</b>	<b>3-12</b>
<b>3-4</b>	<b>Connectors .....</b>	<b>3-13</b>
3-4-1	Power Connector .....	3-13
3-4-2	I/O Connector .....	3-13
3-4-3	USB Connectors .....	3-14
3-4-4	Ethernet Connectors .....	3-15
3-4-5	DisplayPort Connector (Optional) .....	3-15
3-4-6	DVI Connector (Optional) .....	3-16
3-4-7	RS-232C Connector (Optional) .....	3-17
3-4-8	DVI-D Connector (Optional) .....	3-17
3-4-9	NY Monitor Link Connector (Optional) .....	3-18
3-4-10	Ethernet Connector (Optional) .....	3-19
<b>3-5</b>	<b>SD Memory Card Slot (Optional) .....</b>	<b>3-20</b>
<b>3-6</b>	<b>CFast Card, Battery Slot (Optional) .....</b>	<b>3-21</b>
3-6-1	CFast Card Slot (Optional) .....	3-22
3-6-2	Battery Slot (Optional) .....	3-22
<b>3-7</b>	<b>Drive Bays .....</b>	<b>3-23</b>
<b>3-8</b>	<b>PCIe Card Slot .....</b>	<b>3-24</b>
<b>3-9</b>	<b>Spare Parts .....</b>	<b>3-25</b>
3-9-1	Battery .....	3-25
3-9-2	Fan Unit .....	3-25
3-9-3	Accessory Kit .....	3-26
3-9-4	Connectors .....	3-26
<b>3-10</b>	<b>Optional Hardware .....</b>	<b>3-27</b>
3-10-1	VESA Mount Brackets .....	3-27
3-10-2	SD Memory Cards .....	3-28
3-10-3	CFast Cards .....	3-28

3-10-4	HDD and SSD Storage Devices.....	3-29
3-10-5	DVI Cables .....	3-31
3-10-6	USB Type-A to USB Type-B Cables.....	3-31
3-10-7	NY Monitor Link Cables.....	3-32
3-10-8	Industrial Monitor .....	3-35
3-10-9	Power Supply .....	3-35
3-10-10	UPS .....	3-36
3-10-11	UPS Communication Cable.....	3-36

## 3-1 Layers and Components

This section shows the layers of the Industrial Panel PC.

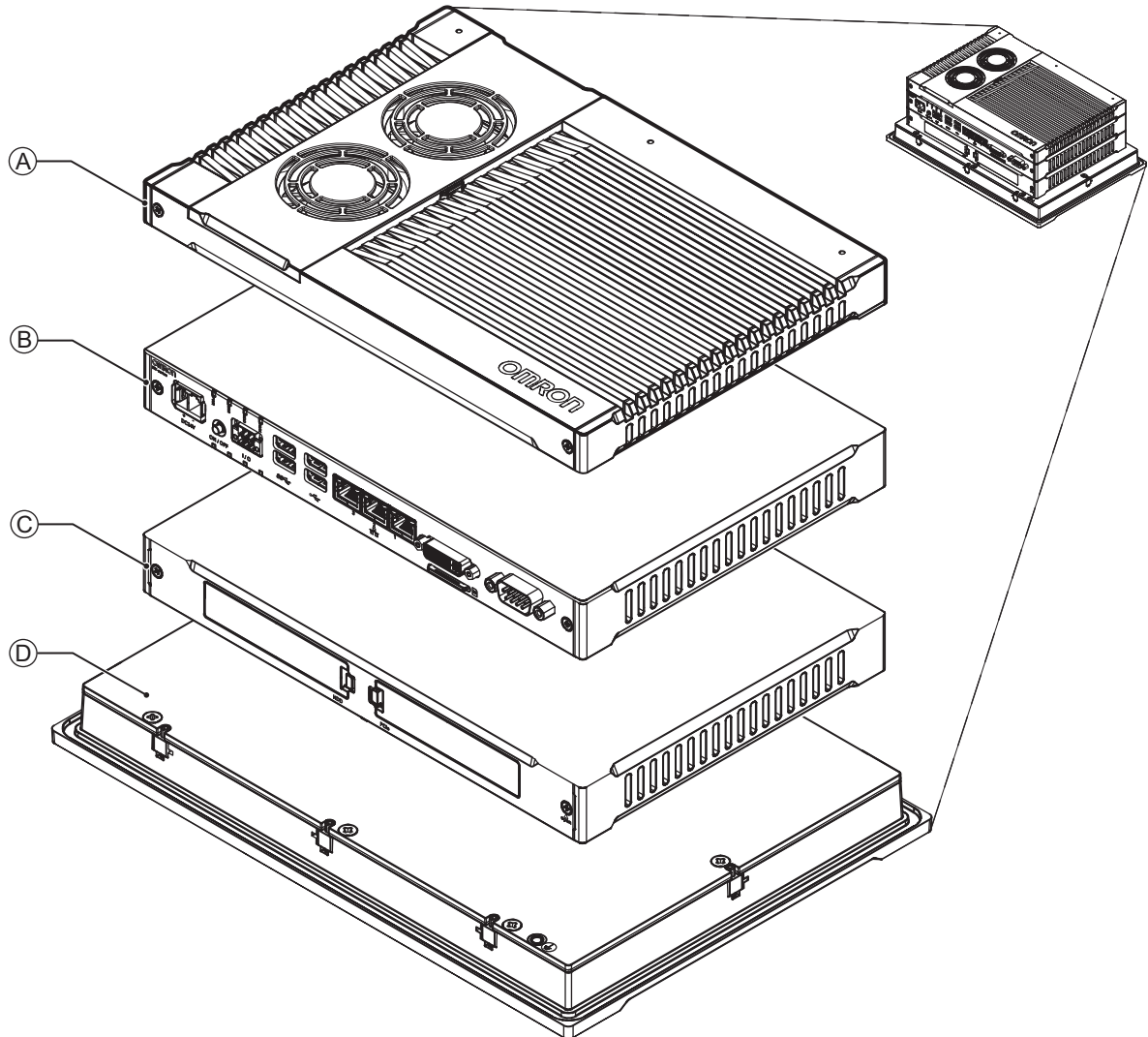

Item	Name	Description
A	Cooling layer	Layer to cool the base layer Depending on the product configuration fans can be present and the thickness can vary.
B	Base layer	The layer with the CPU and the main interfaces The connector layout and the installed option board depend on the product configuration.
C	Expansion layer	Depending on the product configuration this optional layer can add additional storage devices or a PCIe Card.
D	Display layer	Multi-touch LCD display to interact with the user.

### 3-1-1 Cooling Layer

This section gives details on the cooling layer.

The cooling layer will dissipate excessive heat from the Panel PC.

Thickness and design details of the cooling layer can vary, depending on the product configuration.

Cooling layer with removable cover and active cooling

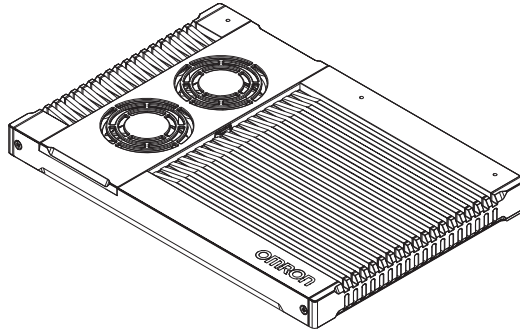

The cover provides access to:

- The battery
- The battery replacement date
- The fans, only for Panel PCs that have active cooling

Cooling layer with removable cover and passive cooling

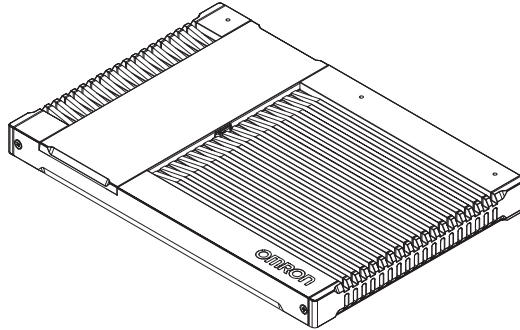

The cover provides access to:

- The battery
- The battery replacement date

Cooling layer with passive cooling and a non-removable cover

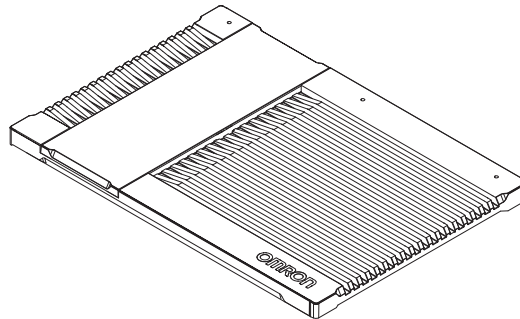

A thin cooling layer for passive cooling

## 3-1-2 Base Layer

This section shows the component names and functions for the base layer.  
The base layer houses most of the functionality of the Panel PC.

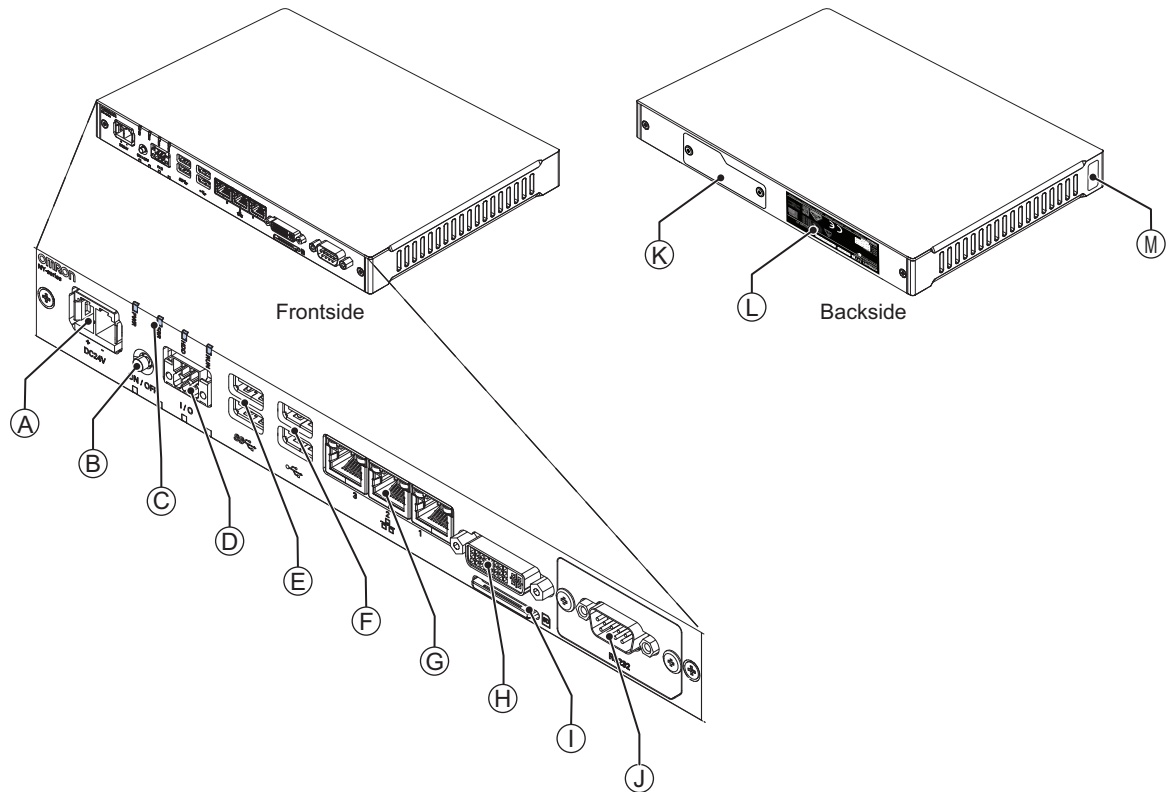

The connector layout and the available components can differ depending on the product configuration. Refer to *1-4 Product Configuration Panel PC* on page 1-5 for configuration details.

Item	Name	Description
A	Power connector	Lockable power connector
B	Power button	Pushbutton to manually power ON/OFF the Panel PC
C	LED indicators	Visual indicators for the operating state of the Panel PC
D	I/O connector	2 Inputs and 1 Output
E	USB connectors	2 USB interface connectors
F	USB connectors	2 USB interface connectors
G	Ethernet connectors	3 RJ45 Gb Ethernet interface connectors
H	Video connector	Video options are: <ul style="list-style-type: none"> <li>• DisplayPort (video and audio)</li> <li>• Digital Visual Interface connector (video)</li> </ul>
I	SD Memory Card slot	Optional SD Memory Card slot
J	Option port	Interface connection options for peripheral devices or an additional monitor. Possible option ports are: <ul style="list-style-type: none"> <li>• RS-232C connector</li> <li>• DVI-D connector</li> <li>• DisplayPort (video and audio) connector</li> <li>• NYML connector</li> <li>• RJ45 Gb Ethernet connector</li> </ul>
K	Storage slot	Optional CFAST Card slot and optional Battery slot

Item	Name	Description
L	ID information label	Label containing model-ID, LOT No. and other product specific information. Refer to <i>1-3 ID Information Label</i> on page 1-4 for label details.
M	License label	The license label contains the product key for the operating system (optional). The product key is inside the cover of the cooling layer for lotnumbers before 22Z17.

### 3-1-3 Expansion Layer (Optional)

This section shows the component names and functions for the expansion layer.

The expansion layer adds additional functionality to the base layer.

The Expansion Layer is available for models:

- NYB□□-□1, NYB□□-□2
- NYP□□-□1, NYP□□-□2

Refer to *1-4 Product Configuration Panel PC* on page 1-5 for model details.

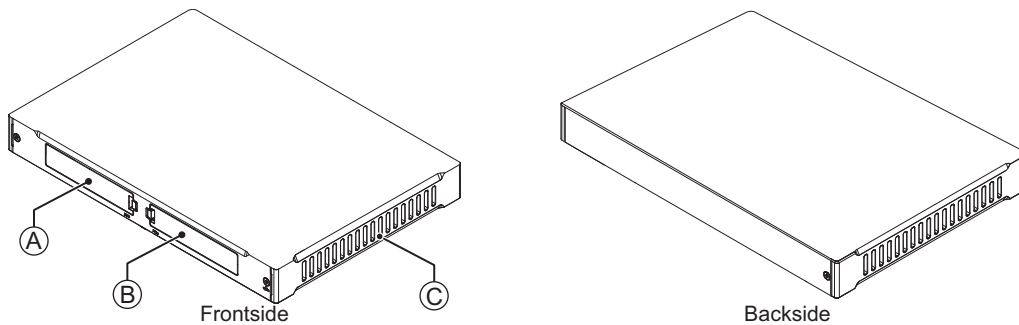

Item	Name	Description
A	Drive bays *1	Two 2.5 inch drive bays for HDD/SSD storage devices: <ul style="list-style-type: none"> <li>• Drive bay A is the bay at the side of the base layer.</li> <li>• Drive bay B is the bay at the opposite side of the base layer.</li> </ul>
B	PCIe bay	PCI Express mounting slot
C	PCIe drawer	Mounting location for the PCIe Card

\*1. Depending on the model one or two drives are supported.

Refer to *4-1-7 Storage Device Specifications* on page 4-17 for the number of supported drives and for bay details.

### 3-1-4 Display Layer

This section shows the component names and functions for the display layer.  
The main function of the display layer is to show content and interact with the user.

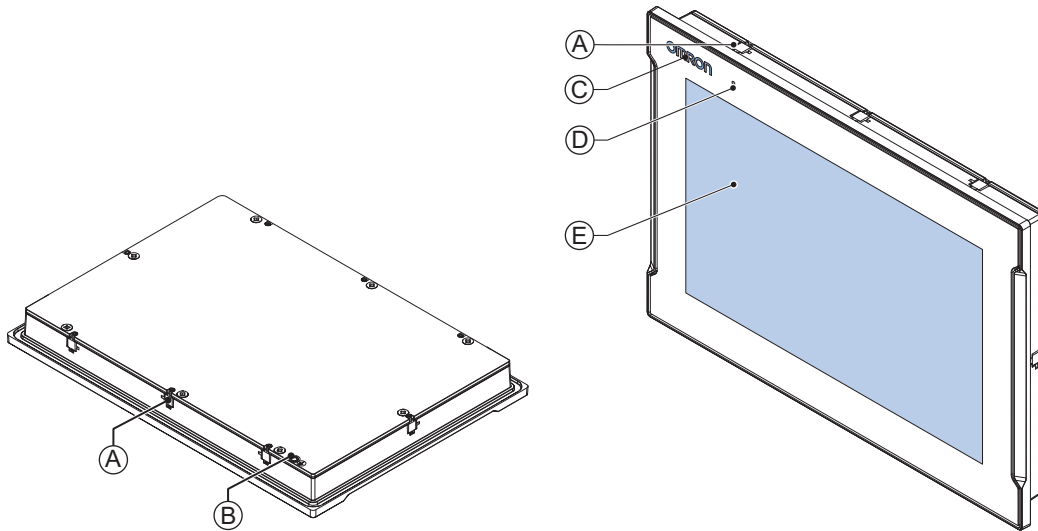

Item	Name	Description
A	Mounting brackets	Retractable mounting brackets to secure the display layer on a mounting surface
B	Ground terminal	Provides a ground terminal for the Panel PC
C	Logo LED	Backlit logo with adjustable brightness
D	Status LED indicator	LED to indicate power and connection status with adjustable brightness
E	Touchscreen LCD	Multi-touch LCD display

## 3-2 LED Indicators

The Industrial Panel PC has LED indicators located at the base layer and at the display layer. These LED indicators provide the current operating status of the Industrial Panel PC.

### 3-2-1 LED Indicators Display Layer

The display layer has a logo LED and a Status LED indicator.

The Status LED indicator provides the same information as the Power and Error LEDs on the base layer.

The following LEDs are available on the display layer of the Industrial Panel PC.

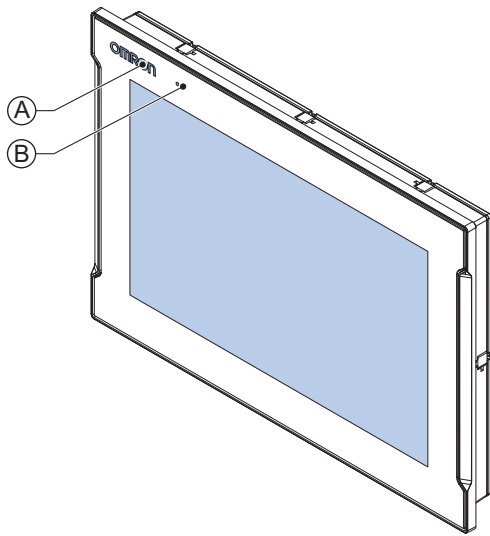

Item	LED	Description
A	Logo LED	LED to backlight the logo
B	Status LED Indicator	Indicates the status of the Panel PC

## Logo LED

The Logo LED brightness can be changed with the Industrial Monitor Utility.







### Additional Information

The Logo LED brightness is adjustable with the Industrial Monitor Utility. Refer to NY-series Operating Systems and Software Utilities Manual (Cat. No. W616) for Industrial Monitor Utility details.

## Status LED Indicator

The Status LED indicator provides information about the operating condition of the Panel PC. The Status LED brightness can be changed with the Industrial Monitor Utility.

Color	Status	Meaning
None		Not lit One of the following situations: <ul style="list-style-type: none"> <li>The 24 VDC power is not supplied.</li> <li>Normal operation</li> <li>Turned OFF by the Industrial Monitor Utility.</li> </ul>
Green		Blinking Power is currently supplied and the Industrial Panel PC is in stand-by mode.
Red		Blinking One of the following situations: <ul style="list-style-type: none"> <li>Fan Error, only for Panel PCs that have active cooling</li> <li>Battery low</li> </ul>
Red		Lit At maximum brightness in following situations: <ul style="list-style-type: none"> <li>Power supply undervoltage error</li> <li>Power supply overvoltage error</li> <li>Power supply defective</li> <li>Monitor internal hardware error</li> </ul> At controllable brightness in following situations: <ul style="list-style-type: none"> <li>Thermal shutdown</li> <li>Watchdog Error</li> </ul>



### Additional Information

- Refer to Industrial Monitor Utility information for brightness adjustment details.
- For Panel PCs without Machine Controller Software the status of this LED can also be defined by the Industrial Monitor API.
- The Industrial Monitor Utility information and the Monitor API information are available:
  - For products NYP□ in the NY-series Operating Systems and Software Utilities Manual (Cat. No. W616)
  - For products NY5□ in the *NY-series IPC Machine Controller Industrial Panel PC / Industrial Box PC Setup User's Manual* (Cat. No. W568)

### 3-2-2 LED Indicators Base Layer

The base layer has LED indicators that show the operating status of the Industrial Panel PC.

Depending on the model a second row with LED indicators (E) can be available with LEDs that have the same function.

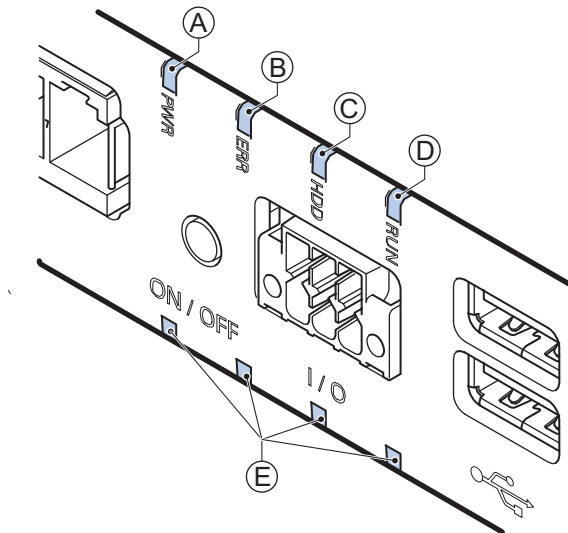

The following LED indicators are available:



Item	LED Indicator	Name	Description
A	PWR	Power	Indicates the operating mode of the Industrial Panel PC.
B	ERR	Error	Indicates the presence and type of an error.
C	HDD	Hard Disk Drive	Indicates HDD/SSD/CFast activity.
D	RUN	Run	Indicates the status of a user-defined function.
E	-	-	An optional second row of LEDs A, B, C and D.



#### PWR LED Indicator

The Power LED (PWR) indicates the operating mode of the Panel PC.

Color	Status	Meaning	
Green		Not lit	There is no power supplied or the Panel PC is OFF.
		Blinking	Power is currently supplied and the Panel PC is in stand-by mode.
		Lit	Power is currently supplied and the Panel PC is turned ON.

## ERR LED Indicator

The Error LED (ERR) indicates the presence and type of an error within the Industrial Panel PC.

Color	Status	Meaning
Red		Not lit
		Blinking
		Lit
		<ul style="list-style-type: none"> <li>The 24 VDC power is not supplied</li> <li>No error is present</li> <li>Fan Error</li> <li>Battery low<sup>*1</sup></li> <li>Thermal shutdown</li> <li>Watchdog Error</li> <li>Power Supply undervoltage error</li> <li>Power Supply overvoltage error</li> <li>Power supply defective</li> </ul>

\*1. It can take up to one minute after battery replacement before the Battery low error is resolved.



### Additional Information

- The status of this LED can also be defined by users using the Industrial PC System API. Refer to *NY-series Operating Systems and Software Utilities Manual (Cat. No. W616)* for Industrial PC System API for API details.
- Refer to *7-2 Corrective Maintenance* on page 7-5 for actions to solve errors.



## HDD LED Indicator

The Hard Disk Drive LED (HDD) indicates activity of the storage device.

Color	Status	Meaning
Yellow		Flickering
		The storage device is active.

## RUN LED Indicator

The RUN LED is available for user applications.

Color	Status	Meaning
Green		Not lit
		Blinking
		Lit
		User-defined. The status can be defined in a user program using the Industrial PC System API.



### Additional Information

Refer to *NY-series Operating Systems and Software Utilities Manual (Cat. No. W616)* for Industrial PC System API for API details.

## 3-3 Power Button

---

The power button is located at the base layer.

The power button is used to manually switch the Panel PC ON and OFF.

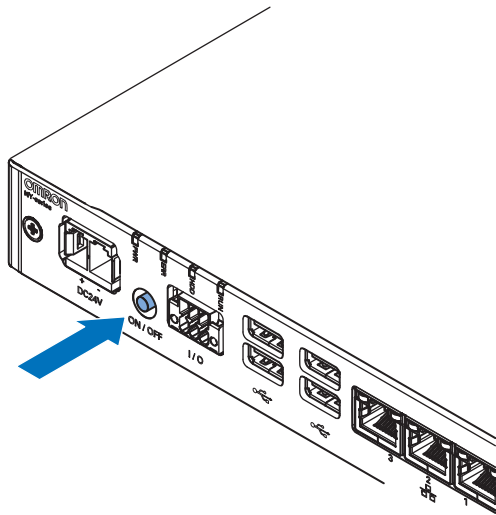

---

### Additional Information

- Refer to 6-2 *Power ON* on page 6-3 for ON details.
  - Refer to 6-3 *Power OFF* on page 6-5 for OFF details.
-

## 3-4 Connectors

This section gives an overview of the connectors located at the base layer of the Industrial Panel PC.

### 3-4-1 Power Connector

The power connector on the Panel PC is used to supply 24 VDC power to the Panel PC. The power connector is supplied with the Panel PC.

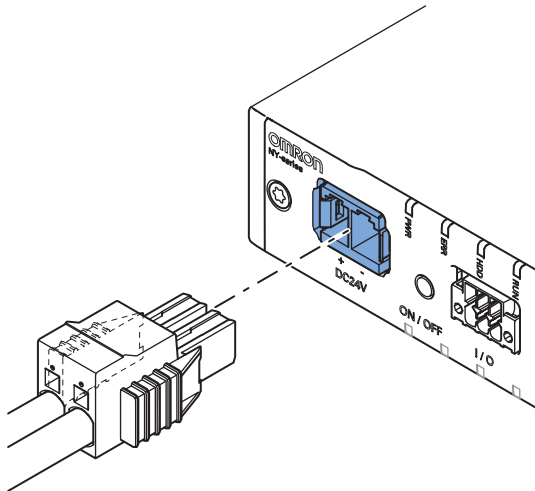

#### Additional Information

- Refer to *4-2-1 Power Connector Specifications* on page 4-26 for specifications.
- Refer to *5-4-3 Wire the Power Connector* on page 5-38 for wiring details.
- Refer to *5-5 Connect* on page 5-44 for connection details.

### 3-4-2 I/O Connector

The I/O connector on the Industrial Panel PC provides 2 discrete Input signals and 1 discrete Output signal.

An example to use these I/O signals:

- Input 1.  
E.g. to signal to the Panel PC when a connected UPS switches to battery power.
- Input 2.  
E.g. to signal to the Panel PC to perform a shutdown or power ON when the signal turns ON.
- Output 1 to indicate the power status of the Panel PC.

The I/O connector is supplied with the Panel PC.

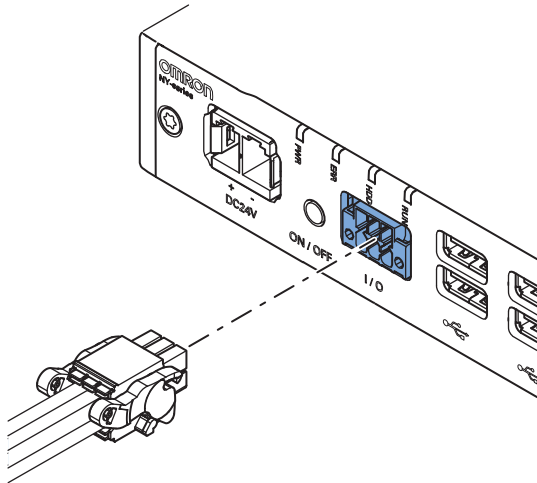

#### Additional Information

- Refer to 4-2-2 *I/O Connector Specifications* on page 4-27 for specifications.
- Refer to 5-4-4 *Wire the I/O Connector* on page 5-41 for wiring details.
- Refer to 5-5 *Connect* on page 5-44 for connection details.

### 3-4-3 USB Connectors

USB connectors support USB 2.x or USB 3.x specifications.  
All USB interfaces are protected against overcurrent.

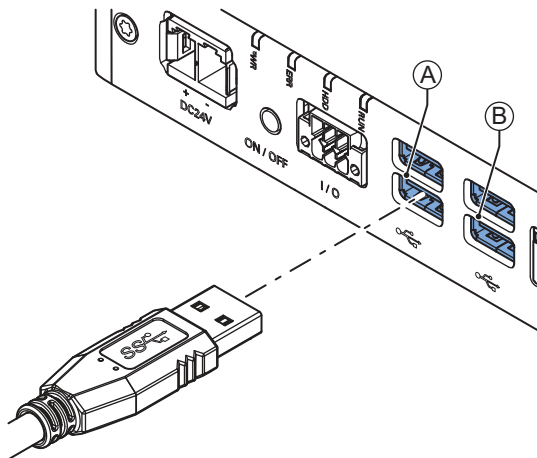

#### Additional Information

- Refer to 4-2-3 *USB Connector Specifications* on page 4-32 for specifications.
- Refer to 5-5 *Connect* on page 5-44 for connection details.

### 3-4-4 Ethernet Connectors

The Ethernet connectors provide individual Ethernet ports on the Industrial Panel PC. Each port offers 10BASE-T/100BASE-TX/1000BASE-T Ethernet speeds.

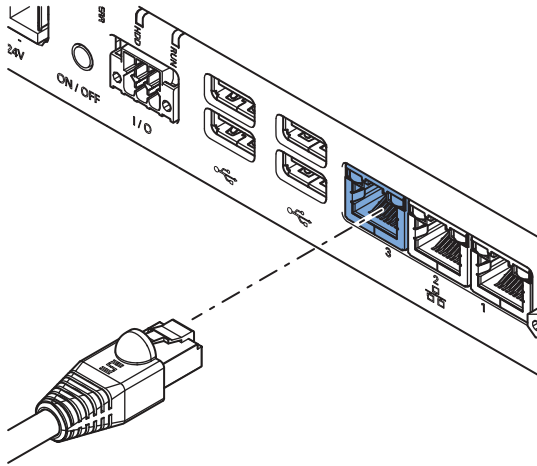

#### Additional Information

- Refer to 4-2-4 *Ethernet Connector Specifications* on page 4-33 for specifications.
- Refer to 5-5 *Connect* on page 5-44 for connection details.

### 3-4-5 DisplayPort Connector (Optional)

On the IPC the DisplayPort interface supported on the left connector is dependent on the configuration of the IPC. The DisplayPort on the right connector is the optional interface.

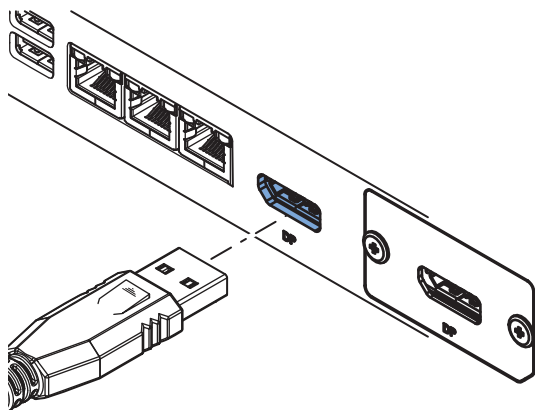

IPC left DisplayPort Connector

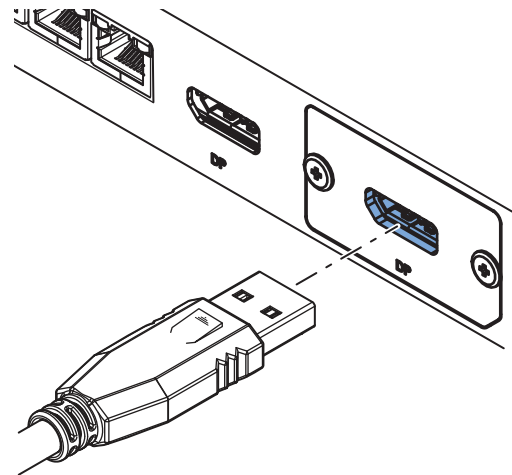

IPC right DisplayPort Connector



#### Additional Information

- Refer to 1-4 *Product Configuration Panel PC* on page 1-5 for configuration details.
- Refer to 4-2-6 *DisplayPort Connector Specifications* on page 4-36 for specifications.
- Refer to 5-5 *Connect* on page 5-44 for connection details.

### 3-4-6 DVI Connector (Optional)

The DVI interfaces supported on this connector are dependent on the configuration of the Industrial Panel PC.

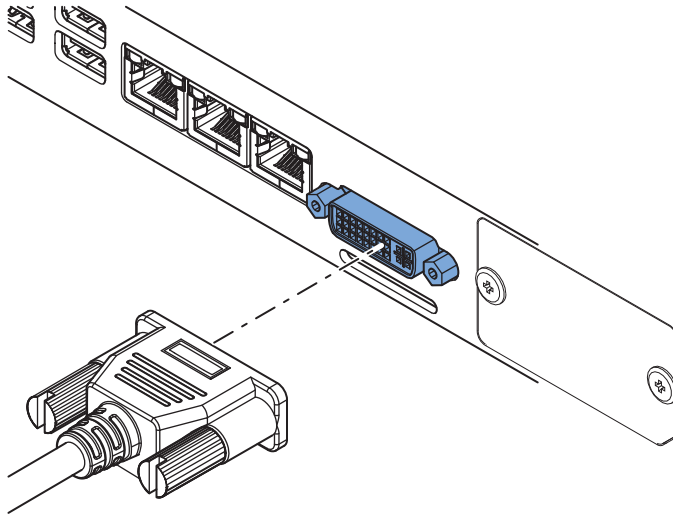

#### Additional Information

- Refer to *1-4 Product Configuration Panel PC* on page 1-5 for configuration details.
- Refer to *4-2-5 DVI Connector Specifications* on page 4-35 for specifications.
- Refer to *5-5 Connect* on page 5-44 for connection details.

### 3-4-7 RS-232C Connector (Optional)

Depending on the product configuration an optional RS-232C connector is available.

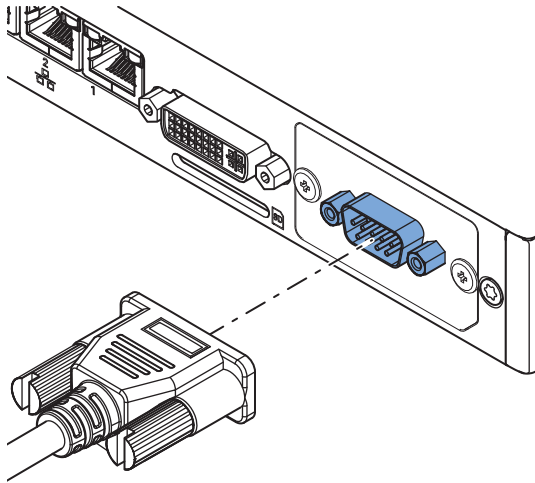

#### Additional Information

- Refer to *1-4 Product Configuration Panel PC* on page 1-5 for configuration details.
- Refer to *4-2-8 RS-232C Connector Specifications* on page 4-38 for specifications.
- Refer to *5-5 Connect* on page 5-44 for connection details.

### 3-4-8 DVI-D Connector (Optional)

Depending on the product configuration an optional DVI-D connector is available. This interface only supports digital video signals.

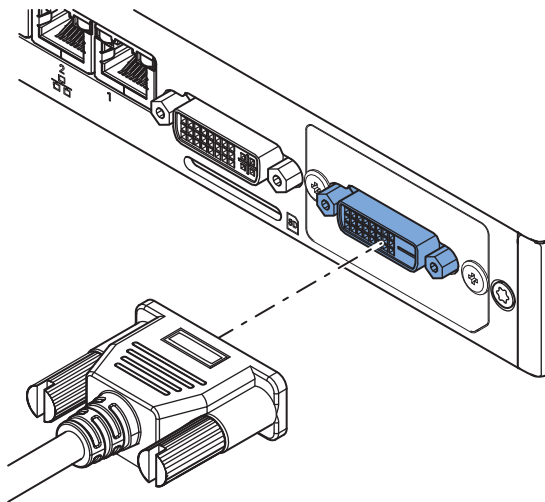

#### Additional Information

- Refer to *1-4 Product Configuration Panel PC* on page 1-5 for configuration details.
- Refer to *4-2-7 DVI-D Connector Specifications* on page 4-37 for specifications.
- Refer to *5-5 Connect* on page 5-44 for connection details.

### 3-4-9 NY Monitor Link Connector (Optional)

The NY Monitor Link interface connector connects an OMRON Industrial PC to an OMRON Industrial Monitor.

Depending on the product configuration an optional NY Monitor Link connector (NYML) is available.

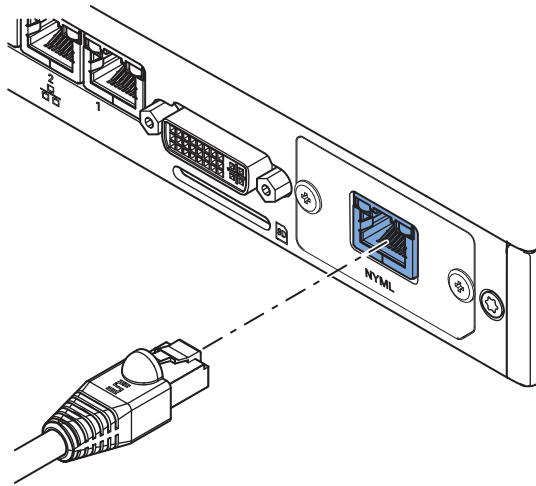

Industrial PC



#### Additional Information

- Refer to *1-4 Product Configuration Panel PC* on page 1-5 for configuration details.
- Refer to *4-2-9 NY Monitor Link Connector Specifications* on page 4-38 for specifications.
- Refer to *5-5 Connect* on page 5-44 for connection details.

### 3-4-10 Ethernet Connector (Optional)

Depending on the product configuration an optional Ethernet connector is available.

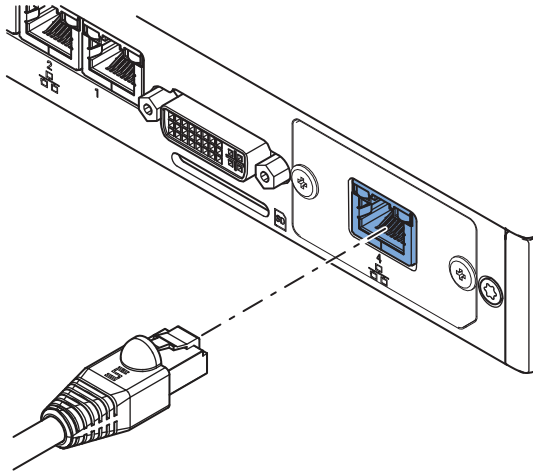

#### Additional Information

- Refer to *1-4 Product Configuration Panel PC* on page 1-5 for configuration details.
- Refer to *4-2-4 Ethernet Connector Specifications* on page 4-33 for specifications.
- Refer to *5-5 Connect* on page 5-44 for connection details.

## 3-5 SD Memory Card Slot (Optional)

---

The SD Memory Card slot is located at the base layer.

The SD Memory Card slot on the Industrial Panel PC accepts SD Memory Cards with the following specifications.

- SDHC type (SD 2.0 specification)
- Up to 32 GB capacity

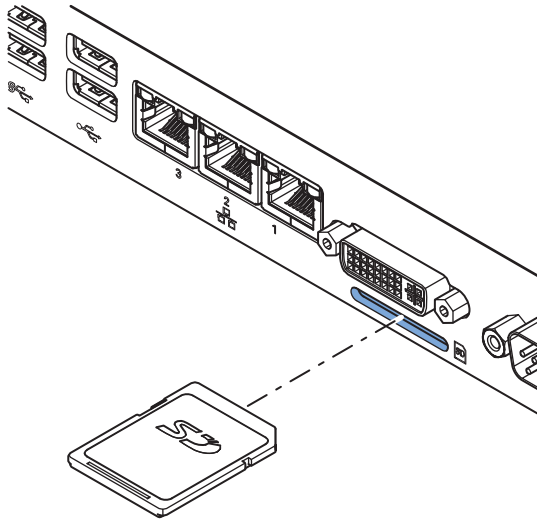

### Additional Information

---

Refer to *3-10-2 SD Memory Cards* on page 3-28 for SD Memory Card details.

---

## 3-6 CFast Card, Battery Slot (Optional)

Depending on the product configuration an optional CFast Card slot and/or an optional Battery are located at the rear side of the base layer.

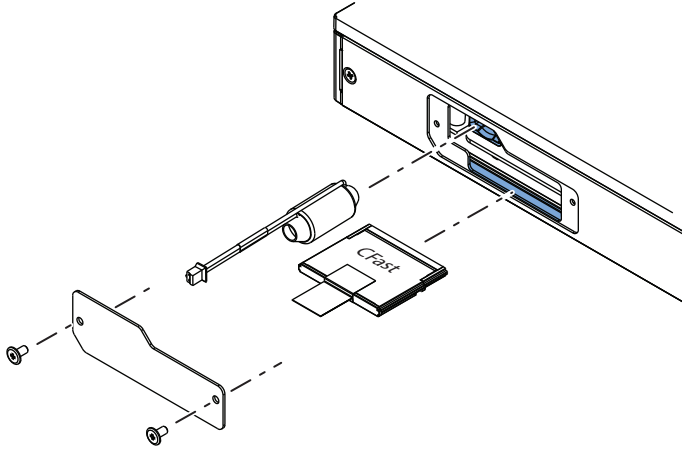

### Additional Information

- Refer to 3-6-1 *CFast Card Slot (Optional)* on page 3-22 for more information.
- Refer to 3-6-2 *Battery Slot (Optional)* on page 3-22 for more information.

### 3-6-1 CFast Card Slot (Optional)

Depending on the product configuration an optional CFast Card slot is located at the rear side of the base layer.

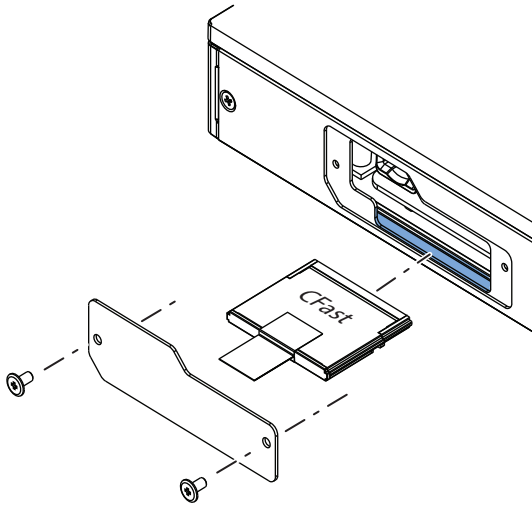

#### Additional Information

Refer to 3-10-3 CFast Cards on page 3-28 for details.

### 3-6-2 Battery Slot (Optional)

Depending on the product configuration a battery can be mounted behind the cover at the rear side of the base layer.

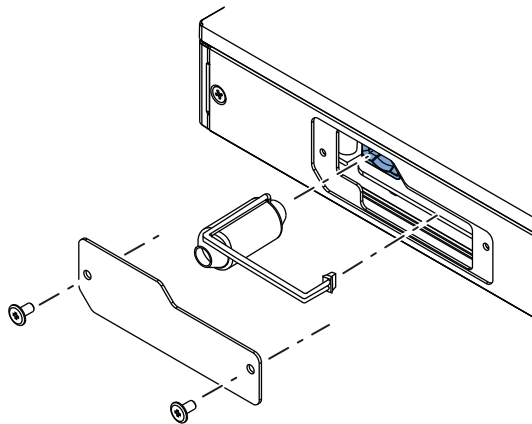

#### Additional Information

Refer to 3-9-1 Battery on page 3-25 for more information.

## 3-7 Drive Bays

The drive bays are located in the expansion layer.

The drive bays in the Industrial Panel PC accept 2.5 inch Hard Disk Drives (HDD) or Solid State Drives (SSD). Depending on the model one or two drives are supported.

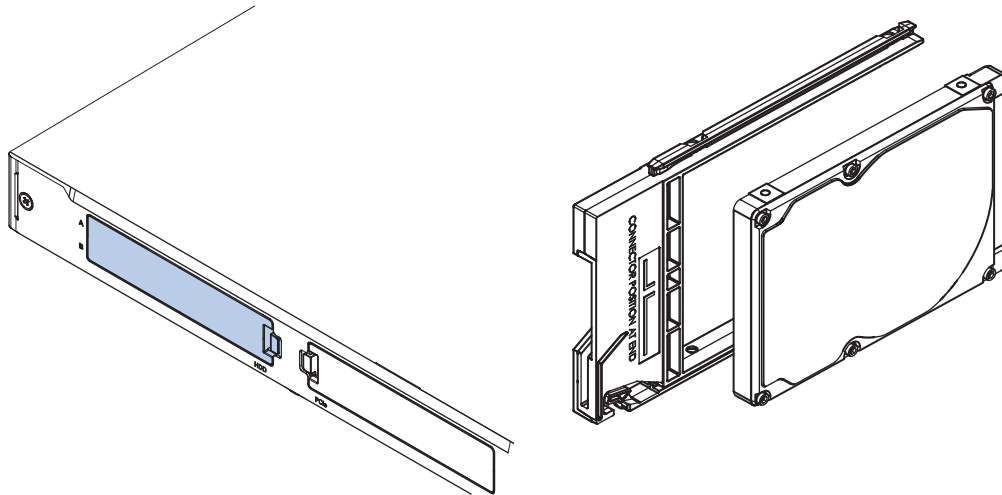

### Additional Information

- Refer to *4-1-5 CPU Specifications* on page 4-10 for the number of supported drives.
- Refer to *4-1-7 Storage Device Specifications* on page 4-17 for storage device specifications.
- Refer to *5-2-1 Install a Drive* on page 5-4 for install information.
- Refer to *7-2-5 Replace a Drive* on page 7-15 for maintenance information.

## 3-8 PCIe Card Slot

---

The PCI Express (PCIe) Card slot is located in the expansion layer.

The PCI Express (PCIe) Card slot of the Industrial Panel PC can accept various PCIe Cards for specific hardware needs.

The PCIe Card connectors are available behind the cover (A) and the PCIe Card is mounted in the PCIe drawer (B).

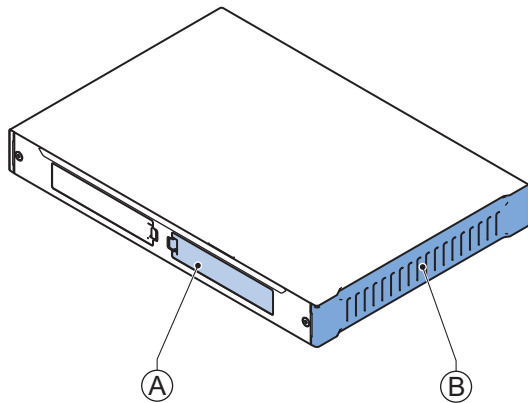

### Additional Information

---

- Refer to *4-1-8 PCIe Card Specifications* on page 4-21 for specifications.
  - Refer to *5-2-2 Install the PCIe Card* on page 5-8 for install information.
  - Refer to *7-2-6 Replace the PCIe Card* on page 7-20 for maintenance information.
-

## 3-9 Spare Parts

The following spare parts for the Industrial Panel PC are available.

### 3-9-1 Battery

One battery is located inside the Panel PC. The battery supplies power to the real-time clock. Refer to *7-2-4 Replace the CJ1W Battery* on page 7-10 for the more information. A non-replaceable battery has a lifetime for at least 10 years at 40°C.

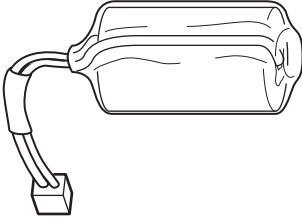
Model	Appearance	Specifications
CJ1W-BAT01		Service life: 5 years at 25°C



#### Additional Information

Refer to the label on the battery for the production date. The manufacturing date is mentioned with YY-MM.  
Production Date



### 3-9-2 Fan Unit

The Fan Unit is available for the Panel PC that has active cooling.

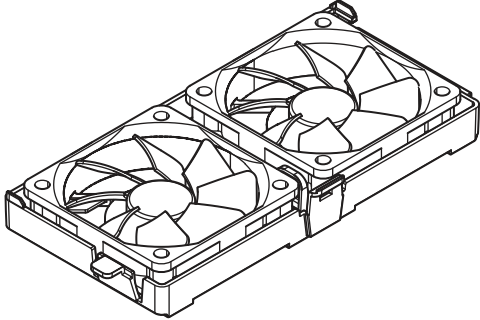
Model	Appearance	Specifications
NY000-AF00		<ul style="list-style-type: none"> <li>• Service life: 70,000 hours of continuous operation at 40°C with 15% to 65% relative humidity</li> <li>• Shelf life: 6 months</li> </ul> <p>This is the storage limitation with no power supplied. We highly recommend performance testing if the Fan Unit has been stored over 6 months.</p>



#### Additional Information

Refer to *7-2-3 Replace the Fan Unit* on page 7-8 for the replacement procedure.

### 3-9-3 Accessory Kit

The accessory kit for the Panel PC.

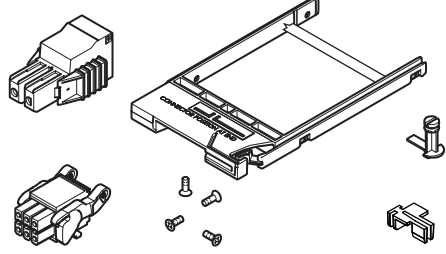
Model	Appearance	Specifications
NY000-AK00		<p>Accessory Kit containing all accessories supplied with the Panel PC.</p> <ul style="list-style-type: none"> <li>• Power connector</li> <li>• I/O connector</li> <li>• Drive bracket for drive installation <sup>*1</sup></li> <li>• 4 mounting screws for drive installation <sup>*1</sup></li> <li>• PCIe Card support for PCIe Card installation <sup>*1</sup></li> <li>• PCIe Card clip for PCIe Card installation <sup>*1</sup></li> </ul>

\*1. The Accessory Kit can contain accessories that are not applicable to your model.  
Refer to *1-4 Product Configuration Panel PC* on page 1-5 for details.

### 3-9-4 Connectors

Details for the recommended connector are provided below.

OMRON is not responsible for the operation or performance of any other connector.

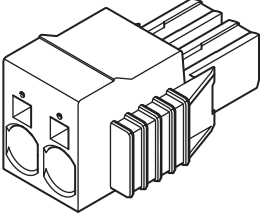
Model	Appearance	Specifications
NY000-AK01		<p>Power Connectors for Omron Industrial PCs. 10 pieces.</p>

## 3-10 Optional Hardware

The following optional hardware is available for the Industrial Panel PC.

### 3-10-1 VESA Mount Brackets

VESA Mount brackets and the optional VESA Mount handle are available for different IPC models. The model-ID is available on the ID information label.

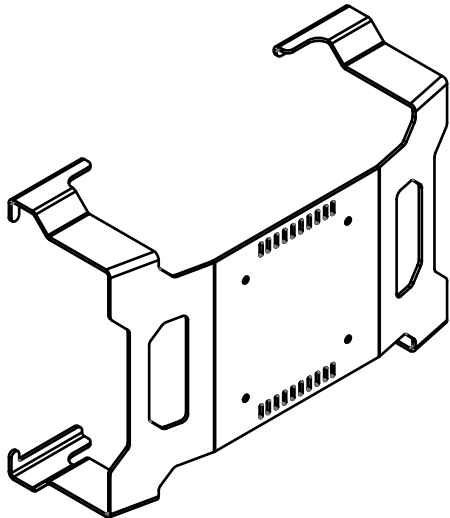
Model	Appearance	Specifications
VESA Mount Bracket		<ul style="list-style-type: none"> <li>Material: stainless steel, 2.5 mm</li> <li>Finish: Black industrial powder coating</li> </ul>

The bracket shape can differ depending on the bracket ID.

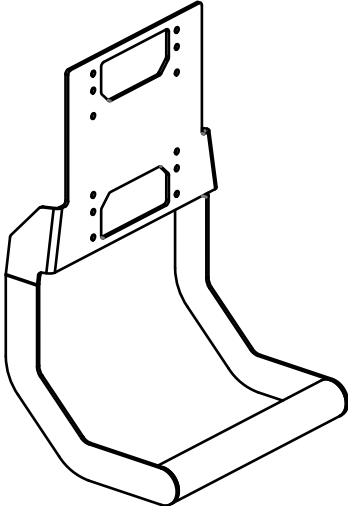
Model	Appearance	Specifications
VESA Mount Handle		<ul style="list-style-type: none"> <li>Material: stainless steel</li> <li>Finish: Black industrial powder coating</li> <li>Handle width outside dimension: 205 mm</li> <li>Handle width inside dimension: 200 mm</li> <li>Handle diameter 30 mm</li> <li>Hole pitch from middle hole:               <ul style="list-style-type: none"> <li>14 mm up</li> <li>21 mm down</li> </ul> </li> </ul>



#### Additional Information

Refer to 4-1-9 VESA Mount Brackets and Handle Specifications on page 4-23 for details.

### 3-10-2 SD Memory Cards

SD Memory Card details are provided below.

OMRON is not responsible for the operation, performance or write life of any other brand of SD Memory Card.

Model	Appearance	Card type	Capacity	Format
HMC-SD292		SD Card	2 GB	FAT16
HMC-SD492		SDHC Card	4 GB	FAT32
HMC-SD1A2		SDHC Card	16 GB	FAT32

### 3-10-3 CFast Cards

CFast Card details are provided below.

OMRON is not responsible for the operation, performance, or write life of any other CFast Card.

Model	Appearance	Storage type	Capacity	Details
NY000-AT00		CFast Card	64 GB	Innodisk DECFA-64GM41BW1DC
NY000-AT01			128 GB	Innodisk DECFA-A28M41BW1DC
NY000-AT02			256 GB	Innodisk DECFA-B56M41BW1DC
NY000-AT05 *1			128 GB	Acon AD5CFPIAR0128085-11
NY000-AT06 *1			256 GB	Acon AD5CFPIAR0256085-11
NY000-AT07 *1			512 GB	Acon AD5CFPIAR0512085-11

\*1. Default for Panel PC models: NY□13, NY□2E, NY□3A, NY□37, NY□55 and NY□65



#### Additional Information

Refer to *CFast Card Specifications* on page 4-20 for CFast Card specifications.

### 3-10-4 HDD and SSD Storage Devices

HDD and SSD storage devices can only be installed in models with an Expansion Layer. Refer to *1-4 Product Configuration Panel PC* on page 1-5 for model details.

HDD and SSD storage device details are provided below.

OMRON is not responsible for the operation, performance, or write life of any other storage device.

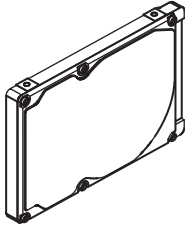
Model	Appearance	Storage type	Capacity	Details
NY000-AH00		HDD	320 GB	Toshiba MQ01ABF032
NY000-AH01			500 GB	Toshiba MQ01ABF050
NY000-AH02			1 TB	WD HTS541010B7E610
NY000-AS00		SSD SLC	32 GB	Apacer APS25AB7032G-AT
NY000-AS01 *1			64 GB	Apacer APS25AB7064G-AT
NY000-AS03 *2			64 GB	Hagiwara HFD25S-064GD(A23AE)-HC
NY000-AS06		SSD-pSLC	128 GB	Innodisk DHS25-A28M41BC1DC
NY000-AS04 *1*2		SSD MLC	128 GB	Innodisk DES25-A28M41BC1DC
NY000-AS08			256 GB	Innodisk DES25-B56M41BC1DC
NY000-AS05			500 GB	Innodisk DES25-C12D08BC1QC
NY000-AS07		3D TLC	1 TB	Innodisk DES25-01TDK1EC1QF
NY000-AS09 *3			128 GB	Acon AD5S27IAR0128070-11
NY000-AS10 *3			256 GB	Acon AD5S27IAR0256070-11
NY000-AS11 *3			512 GB	Acon AD5S27IAR0512070-11
NY000-AS12 *3			1 TB	Acon AD5S27IAR1000070-11
NY000-AS13			2 TB	Acon AD5S27IAR2000070-11

\*1. Default for Panel PC models: NY□25-□1, NY□17-□1 and NY□1C-□1

\*2. Default for Panel PC models: NY□35-□1 and -□2, NY□2C-□1, NY□1E-□1 and -□2, NY□27-□1 and -□2

\*3. Default for Panel PC models: NY□13, NY□2E, NY□3A, NY□37, NY□55 and NY□65



#### Additional Information

Refer to *4-1-7 Storage Device Specifications* on page 4-17 for storage device specifications.

## Storage Device Considerations

---

For a storage device that is not an OMRON NY000-A□□□ consider the following:

- OMRON is not responsible for the operation, performance or write life of any storage device other than those supplied by OMRON.
- Test and measure the environmental performance of the intended storage device before actual operation, using the SMART monitoring feature of the selected storage device.
- Ensure the temperature and vibrations of the storage device are within the operating temperature specifications and vibration specifications during actual operation.
- Using a storage device with maximum power consumption exceeding 2W is not advised. Ensure that the SMART monitor features of the storage device are used to detect overheating.



### Additional Information

---

- Refer to *4-1-7 Storage Device Specifications* on page 4-17 for storage device specifications.
  - Refer to *4-4-1 Operation Environment Specifications* on page 4-42 for environment specifications, specifically temperature and vibration specifications.
-

### 3-10-5 DVI Cables

DVI cable details are provided below.

OMRON is not responsible for the operation or performance of any other brand of DVI cable.

Model	Appearance	Cable length	Specifications
NY000-AC00 2M		2 m	<ul style="list-style-type: none"> <li>• Supports DVI-D</li> <li>• Minimum bend radius: 36 mm</li> </ul>
NY000-AC00 5M		5 m	

#### DVI Cable Clearance

The DVI cable requires a minimum clearance of 90 mm from the connector entry to prevent excessive strain on the connector and cable assembly.

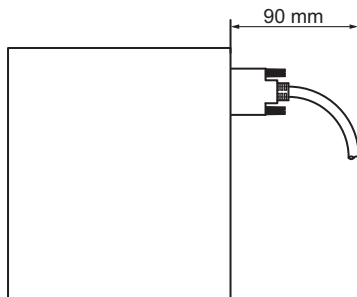

### 3-10-6 USB Type-A to USB Type-B Cables

USB Type-A to USB Type-B cable details are provided below.

OMRON is not responsible for the operation or performance of any other brand of USB Type-A to USB Type-B cable.

Model	Appearance	Cable length	Specifications
FH-VUAB 2M		2 m	<ul style="list-style-type: none"> <li>• USB 2.0</li> <li>• Minimum bend radius: 25 mm</li> </ul>
FH-VUAB 5M		5 m	

#### USB Type-A to USB Type-B Cable Clearance

The USB Type-A to USB Type-B cable requires a minimum clearance of 60 mm from the connector entry to prevent excessive strain on the connector and cable assembly.

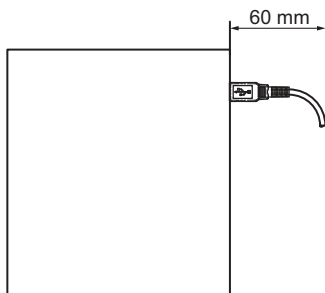

### 3-10-7 NY Monitor Link Cables

Depending on the installation situation specific cables are recommended for an NY Monitor Link (NYML).

Refer to:

- *NYML Recommendations up to 20 m* on page 3-32 for details.
- *NYML Recommendations up to 100 m* on page 3-33 for details.
- *NYML Recommendations for Custom Cables* on page 3-34 for details.

#### NYML Recommendations up to 20 m

Connectors (A) and cables (B) with different lengths can be used.

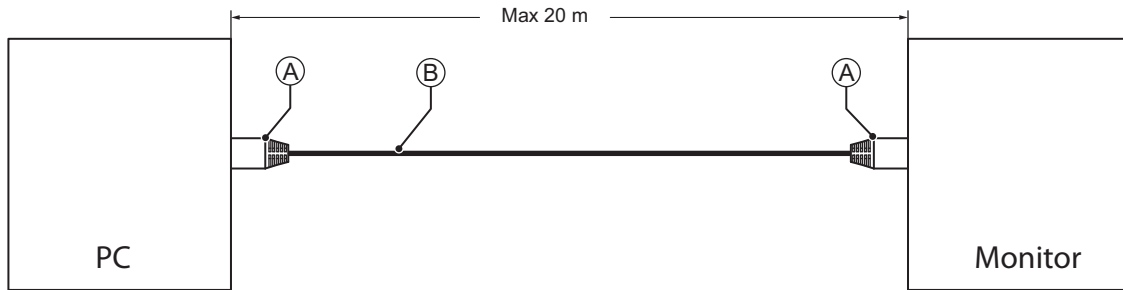

The following table lists the recommended cables and connectors for the NY Monitor Link cable applications up to 20 m.

Item	Length	Specifications	
		ID	Details
Standard Patch cable with straight connectors.	1.5 m	XS6W-6LSZH8SS150CM-[]	Industrial Ethernet cable: RJ45 IP20, RJ45 IP20, Cat.6A, IEC 60332-1 /UL444, LSZH, Molded Connector. Qualified for 10Gb/s, S/FTP
	3 m	XS6W-6LSZH8SS300CM-[]	
	5 m	XS6W-6LSZH8SS500CM-[]	
	10 m	XS6W-6LSZH8SS1000CM-[]	
	15 m	XS6W-6LSZH8SS1500CM-[]	
	20 m	XS6W-6LSZH8SS2000CM-[]	
Patch cable (Flexibility-improved) with straight connectors.	1.5 m	XS6W-6PUR8SS150CM-[]F	Industrial Ethernet cable: RJ45 IP20, RJ45 IP20, Cat.6A, IEC 61156-6, IEC11801, IEC 60332-1, PUR, Molded Connector. Qualified for 10Gb/s, S/FTP
	3 m	XS6W-6PUR8SS300CM-[]F	
	5 m	XS6W-6PUR8SS500CM-[]F	
	10 m	XS6W-6PUR8SS1000CM-[]F	
	15 m	XS6W-6PUR8SS1500CM-[]F	
	20 m	XS6W-6PUR8SS2000CM-[]F	

#### ● NY Monitor Link Cable Clearance

Ensure to prevent excessive strain on the connector and cable assembly.

The minimum clearance from the connector entry consists of the sum of:

- Connector length
- Maximum bending radius of the cable in a fixed position

## NYML Recommendations up to 100 m



Patch Cables (A) with different lengths can be used.

Use a DIN rail socket (B) when connecting patch cables to infrastructures.

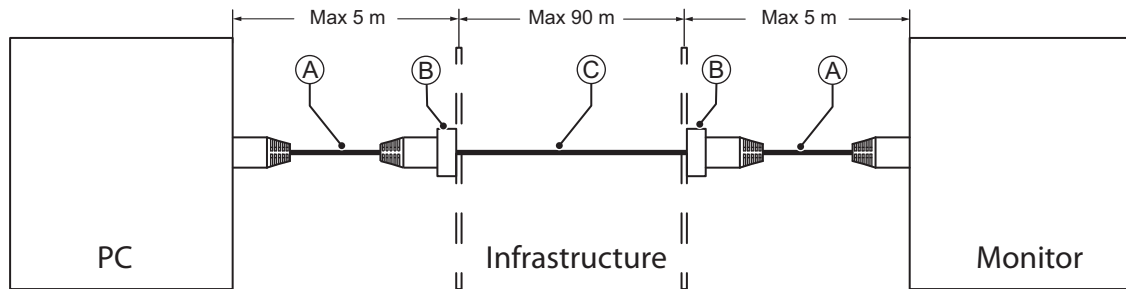
Use installation cable (C) inside infrastructures.



The following table lists the recommended cables and materials for the NY Monitor Link cable applications up to 100 m.

Item	Length	Specifications	
		ID	Details
(A) Standard Patch cable with straight connectors.	1.5 m	XS6W-6LSZH8SS150CM-[]	Industrial Ethernet cable: RJ45 IP20, RJ45 IP20, Cat.6A, IEC 60332-1 /UL444, LSZH, Molded Connector. Qualified for 10Gb/s, S/FTP
	3 m	XS6W-6LSZH8SS300CM-[]	
	5 m	XS6W-6LSZH8SS500CM-[]	
(A) Patch cable (Flexibility-improved) with straight connectors.	1.5 m	XS6W-6PUR8SS150CM-[]F	Industrial Ethernet cable: RJ45 IP20, RJ45 IP20, Cat.6A, IEC 61156-6, IEC11801, IEC 60332-1, PUR, Molded Connector. Qualified for 10Gb/s, S/FTP
	3 m	XS6W-6PUR8SS300CM-[]F	
	5 m	XS6W-6PUR8SS500CM-[]F	
(B) D- DIN rail socket Manufacturer: Weidmuller 		IE-XM-RJ45/IDC	Mounting rail outlet, RJ45 module design according to IEC 60603-7-51, for wires with diameters up to 1.6 mm UL
(C) Installation Cable Manufacturer: Lapp 		ETHERLINE ® PN Cat.6A FLEX	Industrial Ethernet cable ETHERLINE PN Cat.6A FLEX Cat.6A for flexible use, 4 pairs, PVC or FRNC outer sheath UL 4x2xAWG23/7 Qualified for 10Gb/s

### ● NY Monitor Link Cable Clearance

Ensure to prevent excessive strain on the connector and cable assembly.

The minimum clearance from the connector entry consists of the sum of:

- Connector length
- Maximum bending radius of the cable in a fixed position

## NYML Recommendations for Custom Cables

The following table lists the recommended cables and connectors for custom NY Monitor Link cables.

Item		Intra cabinet or light industrial environment	Inter cabinet	Inter cabinet and harsh industrial environment
Maximum length		25 m	100 m	100 m
Manufacturer		Lapp	Lapp	Lapp
Cable type		2170196	2170614	2170466
Category type		Cat 6A	Cat 7	Cat 6A
Cable sheath		Halogen free	Halogen free	Halogen free
Conductor pairs/size/type		4 x 2 x AWG23/1	4 x 2 x AWG23/1	4 x 2 x AWG22/1
Overall shielding		Aluminum foil	Copper braid	Copper braid
Pair shielding		Aluminum foil	Aluminum foil	Aluminum foil
Maximum outer diameter		7.6 mm	7.7 mm	9.0 mm
Maximum bending radius of cable in a fixed position		31 mm	31 mm	90 mm
Maximum temperature for a cable in a fixed position		60°C	60°C	80°C
RJ45 connectors	Manufacturer	Stewart Connector	Stewart Connector	Lapp
	Partnumber	SS39200-027 or SS39200-030	SS39200-027 or SS39200-030	21700600 (T568A) or 21700601 (T568B)
	Connector length	30 mm	30 mm	50 mm



### Additional Information

When making cables, connect the shield to the connectors at both ends.

### ● NY Monitor Link Cable Clearance

Ensure to prevent excessive strain on the connector and cable assembly.

The minimum clearance consists of the sum of:

- Connector length
- Maximum bending radius of cable in a fixed position

### 3-10-8 Industrial Monitor

Details for the recommended monitor are provided below.

OMRON is not responsible for the operation or performance of any other monitor.

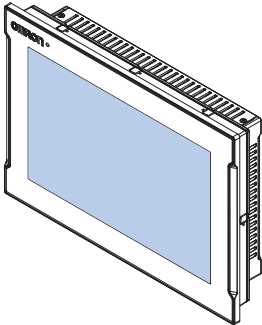
Model	Appearance	Specifications
NYM12W-C1□□□ NYM15W-C1□□□ NYM19W-C1□□□		<ul style="list-style-type: none"> <li>• LCD touchscreen</li> <li>• Multi-touch functionality</li> <li>• Supply voltage: 24 VDC</li> <li>• Up to 1,280 x 800 pixels at 60 Hz (12", 15") or 1,920 x 1,080 pixels at 60 Hz (19")</li> <li>• 2 USB Type-A Connectors</li> <li>• Programmable brightness control</li> </ul>



#### Additional Information

Refer to [the OMRON website](#) for specifications and manuals.

### 3-10-9 Power Supply

Details for the recommended power supply are provided below.

OMRON is not responsible for the operation or performance of any other power supply.

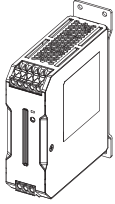
Model	Appearance	Specifications
S8VK-G□□□24 S8VK-X□□□24A-EIP S8VK-S□□□24 S8VK-WA□□□24		Output voltage: 24 VDC



#### Additional Information

- Refer to *4-1-3 Power Consumption Specifications* on page 4-7 for power consumption details.
- Refer to [the OMRON website](#) for specifications and manuals.  
Note that the power consumption details of the Panel PC determine the minimum power rating of your power supply.



# 4

## Specifications

This section provides specifications of the Industrial Panel PC.

<b>4-1</b>	<b>General Specifications</b>	<b>4-2</b>
4-1-1	Dimensions and Weight	4-2
4-1-2	General Electrical Specifications	4-6
4-1-3	Power Consumption Specifications	4-7
4-1-4	Power Supply Specifications	4-9
4-1-5	CPU Specifications	4-10
4-1-6	Memory Specifications	4-15
4-1-7	Storage Device Specifications	4-17
4-1-8	PCIe Card Specifications	4-21
4-1-9	VESA Mount Brackets and Handle Specifications	4-23
<b>4-2</b>	<b>Connector Specifications</b>	<b>4-26</b>
4-2-1	Power Connector Specifications	4-26
4-2-2	I/O Connector Specifications	4-27
4-2-3	USB Connector Specifications	4-32
4-2-4	Ethernet Connector Specifications	4-33
4-2-5	DVI Connector Specifications	4-35
4-2-6	DisplayPort Connector Specifications	4-36
4-2-7	DVI-D Connector Specifications	4-37
4-2-8	RS-232C Connector Specifications	4-38
4-2-9	NY Monitor Link Connector Specifications	4-38
<b>4-3</b>	<b>Display Specifications</b>	<b>4-40</b>
<b>4-4</b>	<b>Environmental Specifications</b>	<b>4-42</b>
4-4-1	Operation Environment Specifications	4-42
4-4-2	Temperature and Humidity Specifications	4-43
4-4-3	Recycling Specifications	4-48

## 4-1 General Specifications

This section provides general specifications of the Industrial Panel PC.

### 4-1-1 Dimensions and Weight

The dimensions and weights can differ depending on the configuration.

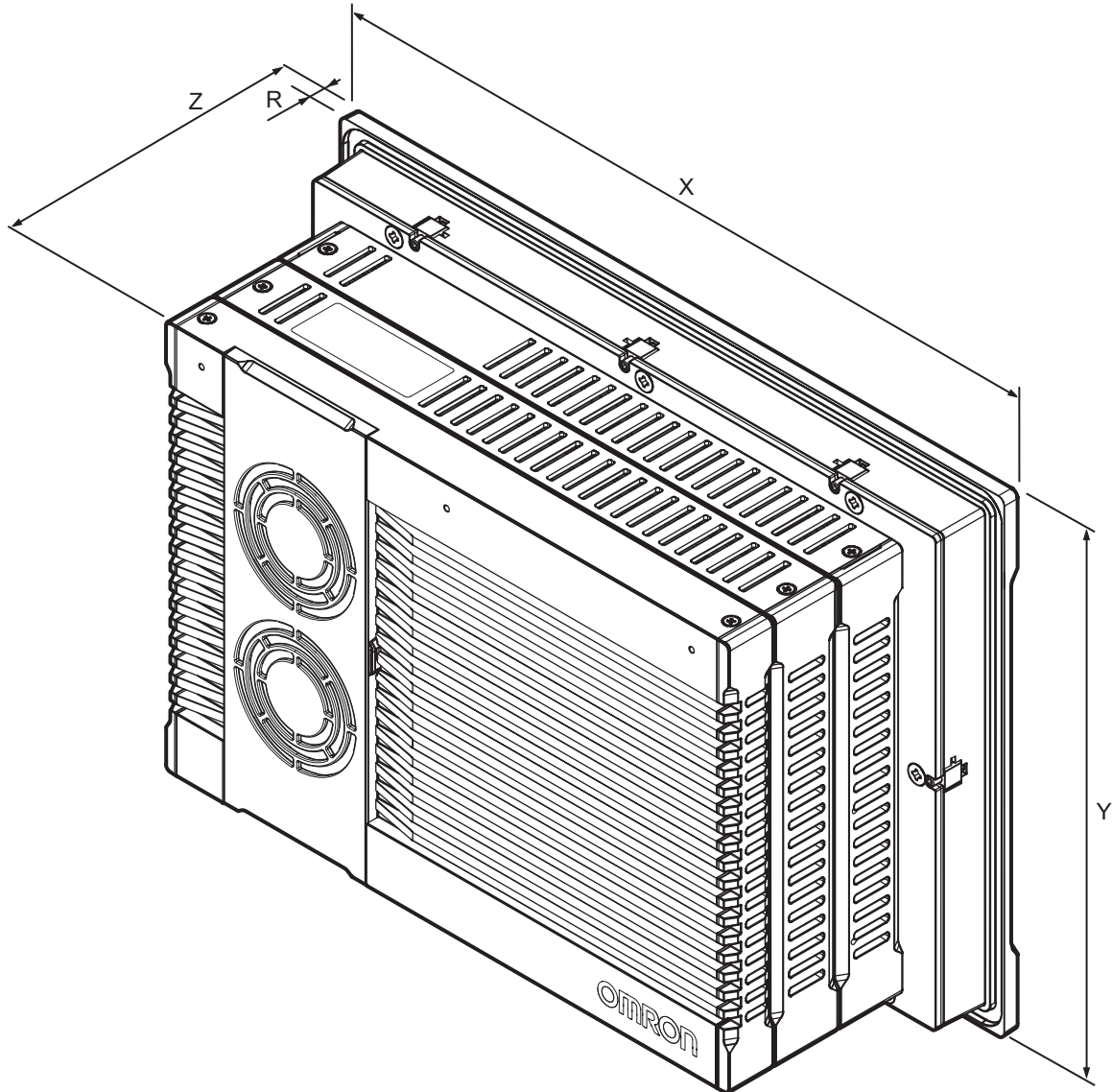

The following tables provide specification details per configuration.

## 12" Display

The following table provides specification details on dimensions and weights for the Industrial Panel PC with 12" display.

Refer to the image in *4-1-1 Dimensions and Weight* on page 4-2 for X, Y, Z and R details.

Model		Specifications				
Model-ID *1 *2	Model Details	Width X	Height Y	Depth Z	Weight	Rim thickness R
<ul style="list-style-type: none"> <li>• NYP1C-□1□□□-12</li> <li>• NYP17-□1□□□-12</li> <li>• NYP25-□1□□□-12</li> <li>• NYP27-□1□□□-12</li> </ul>	Base layer + Expansion layer + Cooling layer with removeable cover.	332 mm	234 mm	121 mm	6.1 kg	8.0 mm
<ul style="list-style-type: none"> <li>• NYP2C-□1□□□-12</li> <li>• NYP35-□1□□□-12</li> </ul>	Base layer + Expansion layer + Cooling layer with non-removeable cover.			105 mm	5.6 kg	
<ul style="list-style-type: none"> <li>• NYP27-□0□□□-12</li> <li>• NYP37-□0□□□-12</li> <li>• NYP55-□0□□□-12</li> </ul>	Base layer + Cooling layer with removeable cover.			88 mm	5.1 kg	
<ul style="list-style-type: none"> <li>• NYP13-□0□□□-12</li> <li>• NYP2A-□0□□□-12</li> <li>• NYP2C-□0□□□-12</li> <li>• NYP3A-□0□□□-12</li> <li>• NYP35-□0□□□-12</li> <li>• NYP65-□0□□□-12</li> </ul>	Base layer + Cooling layer with non-removeable cover.			73 mm	4.7 kg	

\*1. Refer to *1-4 Product Configuration Panel PC* on page 1-5 for product configuration details.

\*2. Refer to *1-3 ID Information Label* on page 1-4 for label details.  
Refer to *3-1-2 Base Layer* on page 3-5 for label location details.

## 15" Display

The following table provides specification details on dimensions and weights for the Industrial Panel PC with 15" display.

Refer to the image in *4-1-1 Dimensions and Weight* on page 4-2 for X, Y, Z and R details.

Model		Specifications				
Model-ID *1 *2	Model Details	Width X	Height Y	Depth Z	Weight	Rim thickness R
<ul style="list-style-type: none"> <li>• NYP1C-□1□□□-15</li> <li>• NYP17-□1□□□-15</li> <li>• NYP25-□1□□□-15</li> <li>• NYP27-□1□□□-15</li> </ul>	Base layer + Expansion layer + Cooling layer with removeable cover.	401 mm	277 mm	121 mm	7.2 kg	8.0 mm
<ul style="list-style-type: none"> <li>• NYP13-□1□□□-15</li> <li>• NYP2C-□1□□□-15</li> <li>• NYP35-□1□□□-15</li> <li>• NYP65-□1□□□-15</li> </ul>	Base layer + Expansion layer + Cooling layer with non-removeable cover.			105 mm	6.6 kg	
<ul style="list-style-type: none"> <li>• NYP27-□0□□□-15</li> <li>• NYP37-□0□□□-15</li> <li>• NYP55-□0□□□-15</li> </ul>	Base layer + Cooling layer with removeable cover.			88 mm	6.0 kg	
<ul style="list-style-type: none"> <li>• NYP13-□0□□□-15</li> <li>• NYP2A-□0□□□-15</li> <li>• NYP2C-□0□□□-15</li> <li>• NYP3A-□0□□□-15</li> <li>• NYP35-□0□□□-15</li> <li>• NYP65-□0□□□-15</li> </ul>	Base layer + Cooling layer with non-removeable cover.			73 mm	5.6 kg	

\*1. Refer to *1-4 Product Configuration Panel PC* on page 1-5 for product configuration details.

\*2. Refer to *1-3 ID Information Label* on page 1-4 for label details.  
Refer to *3-1-2 Base Layer* on page 3-5 for label location details.

## 19" Display

The following table provides specification details on dimensions and weights for the Industrial Panel PC with 19" display.

Refer to the image in *4-1-1 Dimensions and Weight* on page 4-2 for X, Y, Z and R details.

Model		Specifications				
Model-ID *1 *2	Model Details	Width X	Height Y	Depth Z	Weight	Rim thickness R
<ul style="list-style-type: none"> <li>• NYP27-□0□□□-19</li> <li>• NYP37-□0□□□-19</li> <li>• NYP55-□0□□□-19</li> </ul>	Base layer + Cooling layer with removeable cover.	482 mm	304 mm	88 mm	7.0 kg	8.0 mm
<ul style="list-style-type: none"> <li>• NYP13-□0□□□-19</li> <li>• NYP2A-□0□□□-19</li> <li>• NYP2C-□0□□□-19</li> <li>• NYP3A-□0□□□-19</li> <li>• NYP35-□0□□□-19</li> <li>• NYP65-□0□□□-19</li> </ul>	Base layer + Cooling layer with non-removeable cover.	482 mm	304 mm	73 mm	6.6 kg	8.0 mm

\*1. Refer to *1-4 Product Configuration Panel PC* on page 1-5 for product configuration details.

\*2. Refer to *1-3 ID Information Label* on page 1-4 for label details.  
Refer to *3-1-2 Base Layer* on page 3-5 for label location details.

## 4-1-2 General Electrical Specifications

The following table provides the general electrical specifications.

Item	Specifications
Rated power supply voltage	24 VDC
Allowable power supply voltage range	20.4 to 28.8 VDC
Power supply standard	SELV
Grounding method	Ground to less than 100 $\Omega$
Inrush current	At 24 VDC: 12 A / 6 ms max. for cold start at room temperature
Overvoltage category	JIS B3502 and IEC 61131-2: Category II
EMC immunity level	IEC 61131-2: Zone B
RTC accuracy	At ambient temperature of 55°C: -3.5 to +0.5 min error per month At ambient temperature of 25°C: -1.5 to +1.5 min error per month At ambient temperature of 0°C: -3 to +1 min error per month
Power button life	100,000 operations
Fan life	Only for models with active cooling: 8 years of continuous operation at 40°C. Refer to <i>1-4 Product Configuration Panel PC</i> on page 1-5 for details.
Battery life	Refer to Battery for details.

### 4-1-3 Power Consumption Specifications

The total power consumption for the Panel PC is the sum of the power consumption of all installed components.

The following table provides an overview of the components and their power consumption.

Item	Power consumption		
	12.1 inch models *1	15.4 inch models *1	18.5 inch models *1
NYP1C-□1	63 W	63 W	---
NYP13-□0	57 W	52 W	66 W
NYP13-□1	---	52 W	---
NYP17-□1	99 W	99 W	---
NYP2A-□0	42 W	42 W	64 W
NYP2C-□0	43 W	43 W	65 W
NYP2C-□1	43 W	43 W	---
NYP25-□1	70 W	70 W	---
NYP27-□0	101 W	101 W	125 W
NYP27-□1	104 W	104 W	---
NYP3A-□0	40 W	35 W	49 W
NYP35-□0	61 W	61 W	84 W
NYP35-□1	61 W	61 W	---
NYP37-□0	102 W	97 W	111 W
NYP55-□0	87 W	82 W	96 W
NYP65-□0	78 W	73 W	87 W
NYP65-□1	---	73 W	---

\*1. Refer to 1-4 *Product Configuration Panel PC* on page 1-5 for product configuration details.

#### Installed drives

Drives	Power consumption
Bay A	Refer to 4-1-7 <i>Storage Device Specifications</i> on page 4-17 for Omron drive details. For other drives refer to the applicable specifications for maximum power consumption details.
Bay B	
CFast Card Slot	

#### Connected expansions

Expansions	Power consumption
USB	Refer to the power consumption specifications of your connected USB devices. Refer to 4-2-3 <i>USB Connector Specifications</i> on page 4-32 for maximum power consumption details.
PCIe	Refer to the power consumption specifications of the installed PCIe Card. Refer to 4-1-8 <i>PCIe Card Specifications</i> on page 4-21 for maximum power consumption details.

Calculation for the total power consumption:

Industrial Panel PC with my specific CPU	..... W
Depending on the configuration:	
• Drive in bay A	..... W
• Drive in bay B	..... W
• Drive in CFast slot	..... W
• Expansion USB	..... W
• Expansion PCIe	..... W
	_____ +
Total power consumption	..... W



### **Additional Information**

---

Ensure to use a power supply with sufficient capacity.  
Refer to *4-1-4 Power Supply Specifications* on page 4-9 for details.

---

## 4-1-4 Power Supply Specifications

The minimum power supply requirements depend on the maximum power consumption of the Panel PC. Refer to *4-1-3 Power Consumption Specifications* on page 4-7 for details.

With a UPS installed the minimum power requirements are:

Model	Minimum power requirements	
	Power supply <sup>*1</sup>	UPS <sup>*2</sup>
<ul style="list-style-type: none"> <li>• NY□1C</li> <li>• NY□13</li> <li>• NY□2A</li> <li>• NY□2C</li> <li>• NY□25</li> <li>• NY□3A</li> <li>• NY□35</li> <li>• NY□65</li> </ul>	120 W	120 W
<ul style="list-style-type: none"> <li>• NYB17</li> <li>• NYB55</li> </ul>	240 W	120 W
<ul style="list-style-type: none"> <li>• NY□1E</li> <li>• NYP17</li> <li>• NY□2E</li> <li>• NY□27</li> <li>• NY□37</li> <li>• NYP55</li> </ul>	240 W	240 W

\*1. Refer to *3-10-9 Power Supply* on page 3-35 for power supply products.

\*2. Refer to *3-10-10 UPS* on page 3-36 for UPS products.

## 4-1-5 CPU Specifications

This section gives the specifications of the CPUs that are available for the Industrial Panel PC. Refer to *1-4 Product Configuration Panel PC* on page 1-5 for product configuration details.

### NY□1C Intel® Celeron® 2980U CPU Specifications

CPU specifications for an Intel® Celeron® 2980U CPU.

Item	Specifications
Cores / Threads	2 / 2
CPU base frequency	1.6 GHz
Maximum turbo frequency	---
Cache	2 MB
Maximum memory size	16 GB
Cooling details	Passive cooling (fanless)
Graphics controller	Intel® HD Graphics
DDR type	DDR3L-1600, non-ECC

### NY□1E Intel® Xeon® E3-1515M v5 CPU Specifications

CPU specifications for an Intel® Xeon® E3-1515M v5 CPU.

Item	Specifications
Cores / Threads	4 / 8
CPU base frequency	2.8 GHz
Maximum turbo frequency	3.7 GHz
Cache	8 MB
Maximum memory size	64 GB
Cooling details	Requires active cooling (fan)
Graphics controller	Intel® Iris™ Pro Graphics P580
DDR type	DDR4-2400, ECC and non-ECC

### NY□13 Intel® Core™ i3-1115GRE CPU Specifications

CPU specifications for an Intel® Core™ i3-1115GRE CPU.

Item	Specifications
Cores / Threads	2 / 4
CPU base frequency	2.2 GHz
Maximum turbo frequency	3.9 GHz
Cache	6 MB
Maximum memory size	64 GB
Cooling details	Passive cooling (fanless)
Graphics controller	Intel® UHD Graphics
DDR type	DDR4-3200, non-ECC

## NY□17 Intel® Core™ i7-4700EQ CPU Specifications

CPU specifications for an Intel® Core™ i7-4700EQ CPU.

Item	Specifications
Cores / Threads	4 / 8
CPU base frequency	2.4 GHz
Maximum turbo frequency	3.4 GHz
Cache	6 MB
Maximum memory size	32 GB
Cooling details	Requires active cooling (fan)
Graphics controller	Intel® HD Graphics 4600
DDR type	DDR3L-1600, non-ECC

## NY□2A Intel® Atom® x5-E3940 CPU Specifications

CPU specifications for an Intel® Atom® x5-E3940 CPU.

Item	Specifications
Cores / Threads	4 / 4
CPU base frequency	1.6 GHz
Maximum turbo frequency	1.8 GHz
Cache	2 MB
Maximum memory size	8 GB
Cooling details	Passive cooling (fanless)
Graphics controller	Intel® HD Graphics 500
DDR type	DDR3L-1866, non-ECC

## NY□2C Intel® Celeron® 3965U CPU Specifications

CPU specifications for an Intel® Celeron® 3965U CPU.

Item	Specifications
Cores / Threads	2 / 2
CPU base frequency	2.2 GHz
Maximum turbo frequency	---
Cache	2 MB
Maximum memory size	32 GB
Cooling details	Passive cooling (fanless)
Graphics controller	Intel® HD Graphics 610
DDR type	DDR4-2400, non-ECC

## NY□25 Intel® Core™ i5-4300U CPU Specifications

CPU specifications for an Intel® Core™ i5-4300U CPU.

Item	Specifications
Cores / Threads	2 / 4
CPU base frequency	1.9 GHz
Maximum turbo frequency	2.9 GHz
Cache	3 MB
Maximum memory size	16 GB
Cooling details	Passive cooling (fanless)
Graphics controller	Intel® HD Graphics 4400
DDR type	DDR3L-1600, non-ECC

## NY□27 Intel® Core™ i7-7820EQ CPU Specifications

CPU specifications for an Intel® Core™ i7-7820EQ CPU.

Item	Specifications
Cores / Threads	4 / 8
CPU base frequency	3.0 GHz
Maximum turbo frequency	3.7 GHz
Cache	8 MB
Maximum memory size	64 GB
Cooling details	Requires active cooling (fan)
Graphics controller	Intel® HD Graphics 630
DDR type	DDR4-2400, non-ECC

## NY□3A Intel® Atom® x6425RE CPU Specifications

CPU specifications for an Intel® Atom® x6425RE CPU.

Item	Specifications
Cores / Threads	4 / 4
CPU base frequency	1.9 GHz
Maximum turbo frequency	---
Cache	1.5 MB
Maximum memory size	32 GB
Cooling details	Passive cooling (fanless)
Graphics controller	Intel® UHD Graphics
DDR type	DDR4-3200, non-ECC

## NY□35 Intel® Core™ i5-7300U CPU Specifications

CPU specifications for an Intel® Core™ i5-7300U CPU.

Item	Specifications
Cores / Threads	2 / 4
CPU base frequency	2.6 GHz
Maximum turbo frequency	3.5 GHz
Cache	3 MB
Maximum memory size	32 GB
Cooling details	Passive cooling (fanless)
Graphics controller	Intel® HD Graphics 620
DDR type	DDR4-2400, non-ECC

## NY□37 Intel® Core™ i7-1185GRE CPU Specifications

CPU specifications for an Intel® Core™ i7-1185GRE CPU.

Item	Specifications
Cores / Threads	4 / 8
CPU base frequency	2.8 GHz
Maximum turbo frequency	4.4 GHz
Cache	12 MB
Maximum memory size	64 GB
Cooling details	Active cooling
Graphics controller	Intel® Iris® Xe Graphics
DDR type	DDR4-3200, non-ECC

## NY□55 NY□65 Intel® Core™ i5-1145GRE CPU Specifications

CPU specifications for an Intel® Core™ i5-1145GRE CPU.

For products NY□55 with active cooling.

Item	Specifications
Cores / Threads	4 / 8
CPU base frequency	2.6 GHz
Maximum turbo frequency	4.1 GHz
Cache	8 MB
Maximum memory size	64 GB
Cooling details	Active cooling
Graphics controller	Intel® Iris® Xe Graphics
DDR type	DDR4-3200, non-ECC

For products NY□65 with passive cooling.

Item	Specifications
Cores / Threads	4 / 8
CPU base frequency	1.5 GHz
Maximum turbo frequency	4.1 GHz
Cache	8 MB
Maximum memory size	64 GB
Cooling details	Passive cooling (fanless)
Graphics controller	Intel® Iris® Xe Graphics
DDR type	DDR4-3200, non-ECC

## 4-1-6 Memory Specifications

This section provides the memory specifications of the Industrial Panel PC.

### DDR4 Non-ECC

The following table provides specification details of the DDR4 memory.

Item	Model Specifications <sup>*1</sup>					
	4 GB	8 GB	16 GB	32 GB	64 GB	96 GB
Memory configuration	1 x 4 GB	2 x 4 GB	2 x 8 GB	2 x 16 GB	2 x 32 GB	3 x 32 GB
Memory type	DDR4 Non-ECC					
Package memory format	SO-DIMM					
Speed grade - CAS Latency <sup>*2</sup>	2400 MT/s - CL17, 3200 MT/s - CL22					

\*1. The applicable type of memory and the maximum size are determined by the CPU type.

Refer to *4-1-5 CPU Specifications* on page 4-10 for CPU details.

Refer to *1-4 Product Configuration Panel PC* on page 1-5 for product configuration details.

\*2. The actual speed depends on the CPU type.

### DDR4 ECC

The following table provides specification details of the DDR4 memory.

Item	Model Specifications <sup>*1</sup>				
	8 GB	16 GB	32 GB	64 GB	96 GB
Memory configuration	2 x 4 GB	2 x 8 GB	2 x 16 GB	2 x 32 GB	3 x 32 GB
Memory type	DDR4 ECC				
Package memory format	SO-DIMM				
Speed grade - CAS Latency <sup>*2</sup>	2400 MT/s - CL17, 3200 MT/s - CL22				

\*1. The applicable type of memory and the maximum size are determined by the CPU type.

Refer to *4-1-5 CPU Specifications* on page 4-10 for CPU details.

Refer to *1-4 Product Configuration Panel PC* on page 1-5 for product configuration details.

\*2. The actual speed depends on the CPU type.

## DDR3L Non-ECC

The following table provides specification details of the DDR3L memory.

Item	Model Specifications <sup>*1</sup>			
	2 GB	4 GB	8 GB	16 GB
Memory configuration	1 x 2 GB	1 x 4 GB	2 x 4 GB	2 x 8 GB
Memory type	DDR3L Non-ECC			
Package memory format	SO-DIMM			
Serial Presence Detect (SPD)	Speed grade - CAS Latency <sup>*2</sup>	1600 MT/s - CL11 1866 MT/s - CL13		

- \*1. The applicable type of memory and the maximum size are determined by the CPU type.  
Refer to *4-1-5 CPU Specifications* on page 4-10 for CPU details.  
Refer to *1-4 Product Configuration Panel PC* on page 1-5 for product configuration details.
- \*2. The actual speed depends on the CPU type.

## 4-1-7 Storage Device Specifications

This section provides the specifications of the storage devices.

### Hard Disk Drive Specifications

Specifications for the Hard Disk Drive (HDD) are provided in the table below.

Item	Model Specifications		
	320 GB <sup>*1</sup>	500 GB <sup>*1</sup>	1 TB <sup>*1</sup>
Model <sup>*2</sup>	NY000-AH00	NY000-AH01	NY000-AH02
Power consumption	2 W max.		
S.M.A.R.T. support	Yes		
Rotation speed	5,400 r/min		
Operating temperature	5 to 55°C <sup>*3</sup>		0 to 60°C <sup>*3</sup>
Operating humidity (with no condensation)	<ul style="list-style-type: none"> <li>• 8 to 90% RH</li> <li>• 29°C wet-bulb temperature max.</li> </ul>		
Storage temperature	-40 to 65°C		
Storage humidity (with no condensation)	<ul style="list-style-type: none"> <li>• 8 to 90% RH</li> <li>• 40°C wet-bulb temperature max.</li> </ul>		<ul style="list-style-type: none"> <li>• 5 to 95% RH</li> <li>• 40°C wet-bulb temperature max.</li> </ul>
Endurance	Approximately 5 years or 20,000 powered-ON hours (whichever comes first) under the following conditions: <ul style="list-style-type: none"> <li>• 25°C at 101.3 kPa</li> <li>• Less than 333 powered-ON hours/month<sup>*4</sup></li> <li>• Less than 20% operation while powered-ON<sup>*5</sup></li> <li>• Less than 1.30 x 10<sup>6</sup> seeks/month</li> </ul>		Average Annualized Failure Rate (AFR): 0.50% under the following conditions: <ul style="list-style-type: none"> <li>• Case Temperature 40°C</li> <li>• Power on Hours (POH) ≤ 3120</li> </ul>

\*1. Refer to 1-4 *Product Configuration Panel PC* on page 1-5 for product configuration details.

\*2. Refer to 3-10-4 *HDD and SSD Storage Devices* on page 3-29 for brand details.

\*3. Refer to 4-4-1 *Operation Environment Specifications* on page 4-42 for the temperature specifications of the complete Panel PC

\*4. Powered-ON hours include sleep and standby modes.

\*5. Operation includes seeking, writing, and reading functions.

## Solid State Drive Specifications

Specifications for the Solid State Drive (SSD) are provided in two tables:

- The first table for SSDs of type SLC, pSLC and MLC.
- The second table for SSDs of type 3D TLC.

Item	Model Specifications SSD types SLC, pSLC, MLC * <sup>1</sup>						
	32 GB	64 GB		128 GB		256 GB	500 GB
Model * <sup>2</sup>	NY000-AS00	NY000-AS01	NY000-AS03	NY000-AS06	NY000-AS04	NY000-AS08	NY000-AS05
Type	SLC			pSLC	MLC		
Max. power consumption	1.4 W	1.4 W	2.5 W	0.8W	0.8 W	0.8 W	2.7 W
S.M.A.R.T. support	Yes						
Max. sequential read speed	160 MB/s	160 MB/s	500 MB/s	530 MB/s	530 MB/s	530 MB/s	415 MB/s
Max. sequential write speed	145 MB/s	150 MB/s	370 MB/s	380 MB/s	190 MB/s	210 MB/s	200 MB/s
Operating temperature	0 to 70°C * <sup>3</sup>						
Max. operating humidity (with no condensation)	10 to 95% RH	10 to 95% RH	10 to 85% RH	10 to 95% RH	10 to 95% RH	10 to 95% RH	10 to 95% RH
Storage temperature	-40 to 100°C	-40 to 100°C	-45 to 90°C	-55 to 95°C	-55 to 95°C	-55 to 95°C	-55 to 95°C
Max. storage humidity (with no condensation)	10 to 95% RH						
Endurance	749 TBW	1497 TBW	1900 TBW	1389 TBW	208 TBW	416 TBW	154 TBW

\*1. Refer to 1-4 *Product Configuration Panel PC* on page 1-5 for product configuration details.

\*2. Refer to 3-10-4 *HDD and SSD Storage Devices* on page 3-29 for brand details.

\*3. Refer to 4-4-1 *Operation Environment Specifications* on page 4-42 for the temperature specifications of the complete Panel PC.

Item	Model Specifications SSD type 3D TLC *1					
	128 GB	256 GB	512 GB	1 TB	1 TB	2 TB
Model *2	NY000-AS09	NY000-AS10	NY000-AS11	NY000-AS07	NY000-AS12	NY000-AS13
Type	3D TLC					
Max. power consumption	1.2 W	1.3 W	1.6 W	2.2 W	1.7 W	1.8 W
S.M.A.R.T. support	Yes					
Max. sequential read speed	550 MB/s					
Max. sequential write speed	450 MB/s	485 MB/s	500 MB/s	340 MB/s	510 MB/s	510 MB/s
Operating temperature	0 to 70°C *3					
Max. operating humidity (with no condensation)	5 to 90% RH			10 to 95% RH	5 to 90% RH	
Storage temperature	-40 to 85°C			-55 to 95°C	-40 to 85°C	
Max. storage humidity (with no condensation)	5 to 93% RH			10 to 95% RH	5 to 93% RH	
Endurance	90 TBW	230 TBW	550 TBW	1000 TBW	1200 TBW	3000 TBW

\*1. Refer to 1-4 Product Configuration Panel PC on page 1-5 for product configuration details.

\*2. Refer to 3-10-4 HDD and SSD Storage Devices on page 3-29 for brand details.

\*3. Refer to 4-4-1 Operation Environment Specifications on page 4-42 for the temperature specifications of the complete Panel PC.

## CFast Card Specifications

Specifications for the CFast Drive are provided in the table below.

- The first table for CFast Cards of type MLC
- The second table for CFast Cards of type 3D TLC

Item	Model Specifications <sup>*1</sup>		
	64 GB	128 GB	256 GB
Model <sup>*2</sup>	NY000-AT00	NY000-AT01	NY000-AT02
Type	MLC		
Max. power consumption	0.9 W		
Max. sequential read speed	530 MB/s		
Max. sequential write speed	100 MB/s	190 MB/s	210 MB/s
Operating temperature	-40 to 85°C <sup>*3</sup>		
Max. operating humidity (with no condensation)	10 to 95% RH		
Storage temperature	-55 to 95°C		
Max. storage humidity (with no condensation)	10 to 95% RH		
Endurance	125 TBW	208 TBW	417 TBW

<sup>\*1.</sup> Refer to *1-4 Product Configuration Panel PC* on page 1-5 for product configuration details.

<sup>\*2.</sup> Refer to *3-10-3 CFast Cards* on page 3-28 for brand details.

<sup>\*3.</sup> Refer to *4-4-1 Operation Environment Specifications* on page 4-42 for the temperature specifications of the complete Panel PC.

Item	Model Specifications <sup>*1</sup>		
	128 GB	256 GB	512 GB
Model <sup>*2</sup>	NY000-AT05	NY000-AT06	NY000-AT07
Type	3D TLC		
Max. power consumption	1.2 W	1.4 W	1.6 W
Max. sequential read speed	550 MB/s		
Max. sequential write speed	450 MB/s	485 MB/s	500 MB/s
Operating temperature	-40 to 85°C <sup>*3</sup>		
Max. operating humidity (with no condensation)	5 to 90% RH		
Storage temperature	-40 to 85°C		
Max. storage humidity (with no condensation)	5 to 93% RH		
Endurance	90 TBW	230 TBW	550 TBW

<sup>\*1.</sup> Refer to *1-4 Product Configuration Panel PC* on page 1-5 for product configuration details.

<sup>\*2.</sup> Refer to *3-10-3 CFast Cards* on page 3-28 for brand details.

<sup>\*3.</sup> Refer to *4-4-1 Operation Environment Specifications* on page 4-42 for the temperature specifications of the complete Panel PC.

## 4-1-8 PCIe Card Specifications

The PCI Express (PCIe) Card slot of the Industrial Panel PC accepts various cards for specific hardware needs.

Ensure that, according to the PCIe hardware specifications, the indent (A) is present in the PCIe Card.

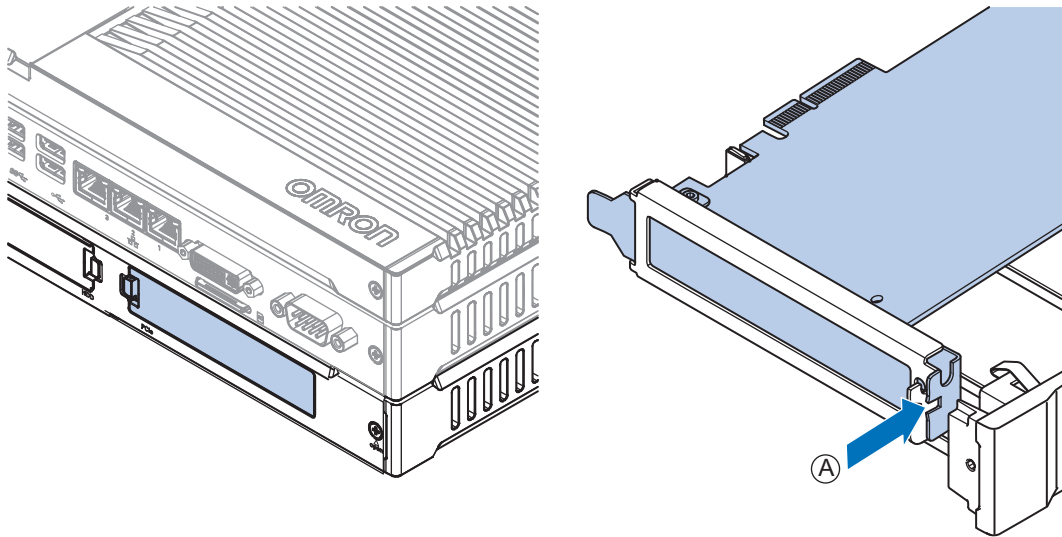

The PCIe Card specifications depend on the CPU and thus on the product configuration.



### Additional Information

Refer to 1-4 Product Configuration Panel PC on page 1-5 for product configuration details.

## PCIe X1 Card Slot Specifications

The table below provides PCIe X1 Card slot details.

Model-ID	Item	Specifications
<ul style="list-style-type: none"> <li>• NY□1C-□1</li> <li>• NY□25-□1</li> </ul>	Configuration	X1 (1 lane) up to Gen 2
	Card height	Standard height cards, 4.20 inches (106.7 mm) <sup>*1</sup>
	Card length	Half-length cards, 6.6 inches (167.65 mm)
	Power consumption	5 W max.
	Maximum current	1.5 A with 3.3 VDC, 0.5 A with 12 VDC

\*1. Low profile cards, 2.536 inches (64.4 mm) are not supported.

## PCIe X2 Card Slot Specifications

The table below provides PCIe X2 Card slot details.

Model-ID	Item	Specifications
<ul style="list-style-type: none"> <li>• NY□2C-□1</li> <li>• NY□35-□1</li> <li>• NY□35-□2</li> </ul>	Configuration	X2 (2 lanes) up to Gen 3
	Card height	Standard height cards, 4.20 inches (106.7 mm) <sup>*1</sup>
	Card length	Half-length cards, 6.6 inches (167.65 mm)
	Power consumption	5 W max.
	Maximum current	1.5 A with 3.3 VDC, 0.5 A with 12 VDC

\*1. Low profile cards, 2.536 inches (64.4 mm) are not supported.

## PCIe X4 Card Slot Specifications

The table below provides PCIe X4 Card slot details.

Cards with max 15 W power consumption.

Model-ID	Item	Specifications
• NY□1E-□1 NY□1E-□2	Configuration	X4 (4 lanes) up to Gen 3
	Card height	Standard height cards, 4.20 inches (106.7 mm) <sup>*1</sup>
• NY□17-□1 NY□27-□1 NY□27-□2	Card length	Half-length cards, 6.6 inches (167.65 mm)
	Power consumption	15 W max.
• NY□2E-□1 NY□2E-□2 • NY□37-□1 NY□37-□2 • NY□55-□1 NY□55-□2	Maximum current	3 A with 3.3 VDC, 1.25 A with 12 VDC

\*1. Low profile cards, 2.536 inches (64.4 mm) are not supported.

Cards with max 5 W power consumption.

Model-ID	Item	Specifications
• NY□13-□1 NY□13-□2	Configuration	X4 (4 lanes) up to Gen 3
	Card height	Standard height cards, 4.20 inches (106.7 mm) <sup>*1</sup>
• NY□65-□1 NY□65-□2	Card length	Half-length cards, 6.6 inches (167.65 mm)
	Power consumption	5 W max.
	Maximum current	1.5 A with 3.3 VDC, 0.5 A with 12 VDC

\*1. Low profile cards, 2.536 inches (64.4 mm) are not supported.

## 4-1-9 VESA Mount Brackets and Handle Specifications

The metal VESA mounting brackets mount your Panel PC.

All VESA Mount Brackets and the optional VESA Mount Handle have VESA Standard FDMI MIS-D with hole pattern 100 \* 100 mm.

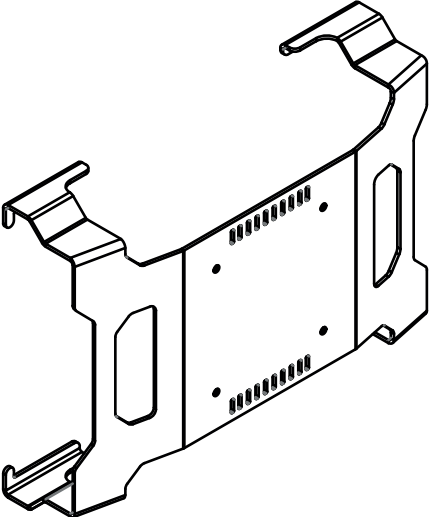
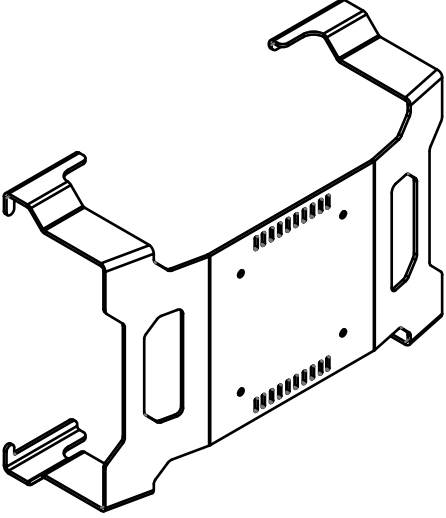
Models 12.1 inch	VESA Mount ID and appearance	Specifications
<ul style="list-style-type: none"> <li>• NYP65-□0□□□-12</li> <li>• NYP35-□0□□□-12</li> <li>• NYP3A-□0□□□-12</li> <li>• NYP2C-□0□□□-12</li> <li>• NYP2A-□0□□□-12</li> <li>• NYP13-□0□□□-12</li> </ul>	<p>NY000-AB06</p> 	<ul style="list-style-type: none"> <li>• Material: stainless steel, 2.5 mm</li> <li>• Finish: Black industrial powder coating</li> <li>• Width: 328 mm</li> <li>• Height: 237 mm</li> <li>• Depth: 86 mm</li> <li>• Weight: 2.7 kg</li> </ul>
<ul style="list-style-type: none"> <li>• NYP55-□0□□□-12</li> <li>• NYP37-□0□□□-12</li> <li>• NYP35-□1□□□-12</li> <li>• NYP2C-□1□□□-12</li> <li>• NYP27-□0□□□-12</li> </ul>	<p>NY000-AB09</p> 	<ul style="list-style-type: none"> <li>• Material: stainless steel, 2.5 mm</li> <li>• Finish: Black industrial powder coating</li> <li>• Width: 328 mm</li> <li>• Height: 237 mm</li> <li>• Depth: 118 mm</li> <li>• Weight: 2.8 kg</li> </ul>

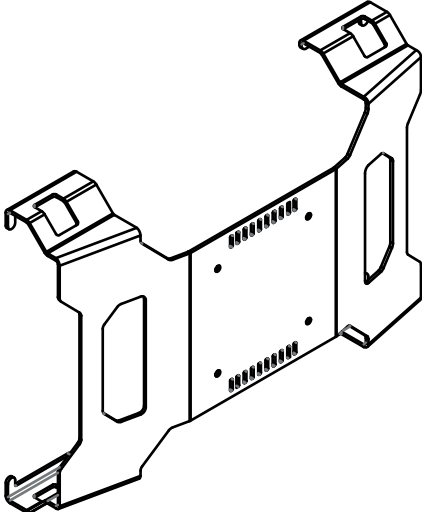
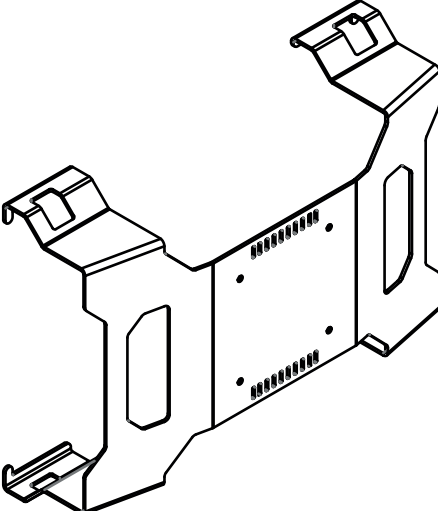
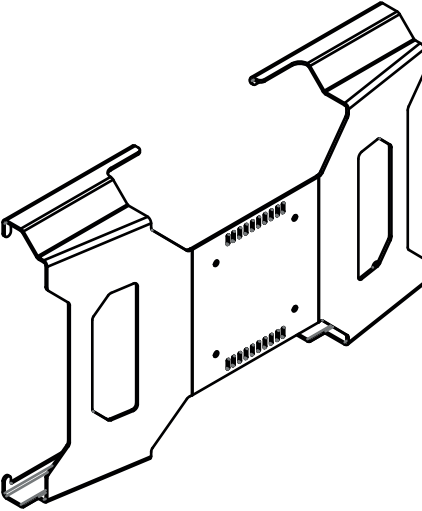
Models 15.4 inch	VESA Mount ID and appearance	Specifications
<ul style="list-style-type: none"> <li>• NYP65-□0□□□-15</li> <li>• NYP35-□0□□□-15</li> <li>• NYP3A-□0□□□-15</li> <li>• NYP2C-□0□□□-15</li> <li>• NYP2A-□0□□□-15</li> <li>• NYP13-□0□□□-15</li> </ul>	<p style="text-align: center;">NY000-AB07</p> 	<ul style="list-style-type: none"> <li>• Material: stainless steel, 2.5 mm</li> <li>• Finish: Black industrial powder coating</li> <li>• Width: 397 mm</li> <li>• Height: 280 mm</li> <li>• Depth: 86 mm</li> <li>• Weight: 3.1 kg</li> </ul>
<ul style="list-style-type: none"> <li>• NYP65-□1□□□-15</li> <li>• NYP55-□0□□□-15</li> <li>• NYP37-□0□□□-15</li> <li>• NYP35-□1□□□-15</li> <li>• NYP2C-□1□□□-15</li> <li>• NYP27-□0□□□-15</li> <li>• NYP13-□1□□□-15</li> </ul>	<p style="text-align: center;">NY000-AB10</p> 	<ul style="list-style-type: none"> <li>• Material: stainless steel, 2.5 mm</li> <li>• Finish: Black industrial powder coating</li> <li>• Width: 397 mm</li> <li>• Height: 280 mm</li> <li>• Depth: 118 mm</li> <li>• Weight: 3.3 kg</li> </ul>
Models 18.5 inch	VESA Mount ID and appearance	Specifications
<ul style="list-style-type: none"> <li>• NYP65-□0□□□-19</li> <li>• NYP35-□0□□□-19</li> <li>• NYP3A-□0□□□-19</li> <li>• NYP2C-□0□□□-19</li> <li>• NYP2A-□0□□□-19</li> <li>• NYP13-□0□□□-19</li> </ul>	<p style="text-align: center;">NY000-AB08</p> 	<ul style="list-style-type: none"> <li>• Material: stainless steel, 2.5 mm</li> <li>• Finish: Black industrial powder coating</li> <li>• Width: 478 mm</li> <li>• Height: 306 mm</li> <li>• Depth: 83 mm</li> <li>• Weight: 3.9 kg</li> </ul>

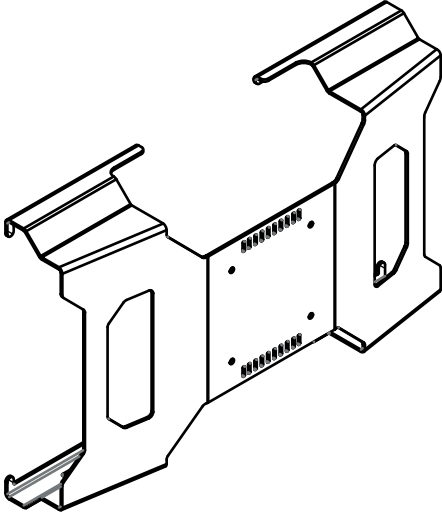
Models 18.5 inch	VESA Mount ID and appearance	Specifications
<ul style="list-style-type: none"> <li>• NYP55-□0□□□-19</li> <li>• NYP37-□0□□□-19</li> <li>• NYP27-□0□□□-19</li> </ul>	<p>NY000-AB11</p> 	<ul style="list-style-type: none"> <li>• Material: stainless steel, 2.5 mm</li> <li>• Finish: Black industrial powder coating</li> <li>• Width: 478 mm</li> <li>• Height: 306 mm</li> <li>• Depth: 98 mm</li> <li>• Weight: 4.0 kg</li> </ul>

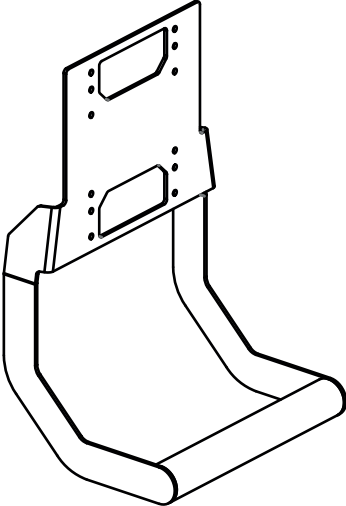
Model	VESA Mount handle ID and appearance	Specifications
<p>Optional VESA Handle for all models with a VESA bracket:</p> <ul style="list-style-type: none"> <li>• All NY-series Panel PCs with a VESA bracket</li> <li>• All NY-series Monitors with a VESA bracket</li> </ul>	<p>NY000-AB12 Optional VESA Handle</p> 	<ul style="list-style-type: none"> <li>• Material: stainless steel</li> <li>• Finish: Black industrial powder coating</li> <li>• Width: 205 mm</li> <li>• Height: 318 mm</li> <li>• Depth: 164 mm</li> <li>• Weight: 2.4 kg</li> <li>• Handle diameter: 30 mm</li> <li>• Hole pitch from middle hole:                             <ul style="list-style-type: none"> <li>14 mm up</li> <li>21 mm down</li> </ul> </li> </ul>



**Additional Information**

Refer to 5-3-9 VESA Mount Procedure on page 5-28 for VESA mount details.

## 4-2 Connector Specifications

This section provides the connector specifications of the Industrial Panel PC.

### 4-2-1 Power Connector Specifications

The power supply connector is locked when inserted to prevent unintentional disconnection.

The connector can only be inserted the correct way.

The connector is a Phoenix Contact type SPC5/2-STCL-7.62 BK (1711708).

The Panel PC provides protection against reverse polarity.

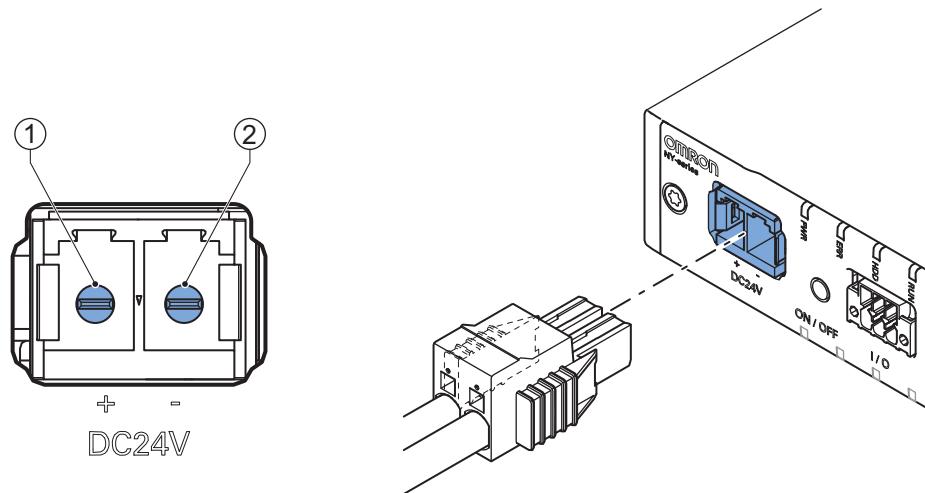

The pin layout represents the power connector on the Panel PC.

Pin	Description
1	24 VDC
2	0 VDC

Item	Specifications
Conductor isolation rating	90°C
Termination rating	90°C



#### Additional Information

- Refer to 5-4-3 *Wire the Power Connector* on page 5-38 for wiring details.
- Refer to 5-4-2 *Ground* on page 5-31 for grounding details.

## Locking and Removing the Power Connector

The power connector automatically locks into place when the black part of the connector is held and pushed in.

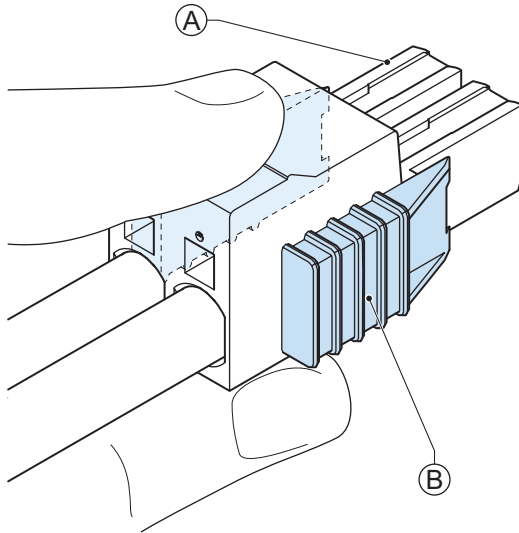

Pushing both orange sliders (B) towards the end of the connector (A) will release the lock when removing the connector.

### 4-2-2 I/O Connector Specifications

Details of the I/O connector are provided below.

Lock the I/O connector when inserted to prevent unintentional disconnection.

The connector can only be inserted in the correct way.

The Lock-and-Release Latch connector is a Phoenix Contact type DFMC 1,5/ 3-ST-3,5-LR BK (1711658).

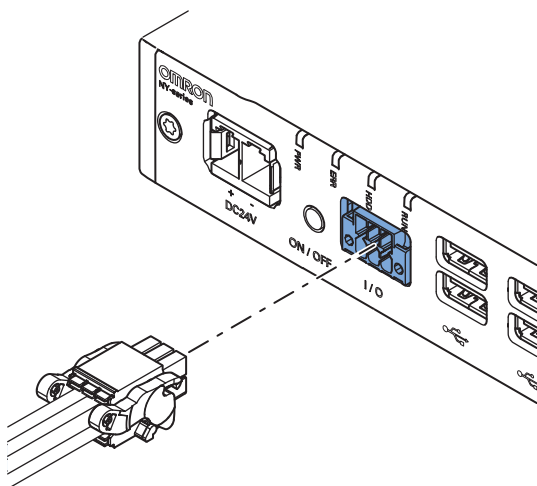

Item	Specifications
Conductor isolation rating	90°C
Termination rating	90°C

## I/O Connector Pin Details

The pin details of the I/O connector.

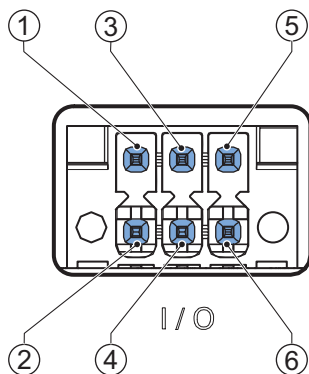

The pin layout represents the I/O connector on the Panel PC.

The I/O signals connected must be powered from a power supply which conforms to the SELV standards.

For model-IDs NY□13, NY□2E, NY□3A, NY□37, NY□55, NY□65 the functionality of the pins of the I/O connector can be reconfigured using the System SDK. Refer to NY-series Software Development Kit User's Manual for configuration details.

Default pin details of the I/O Connector:

Pin	Description	Type	Electrical Specifications	Details
1 2	Output 1 *1	Contact output	<ul style="list-style-type: none"> <li>• SPST-NO contact configuration</li> <li>• 24 VDC at 2A switching capacity (resistive load)</li> <li>• Operation lifetime 150,000 cycles at 2A max.</li> <li>• Connect to SELV</li> </ul>	<ul style="list-style-type: none"> <li>• Open: Output 1 is OFF when the Panel PC is ON or has been disconnected from the power supply.</li> <li>• Closed: Output 1 is ON when the Panel PC has shutdown successfully and is connected to the power supply and has not been disconnected from that power supply since power OFF.</li> </ul> <p>Refer to <i>I/O Connector Output Details</i> on page 4-30 for details.</p>
3 4	Input 1 *2	Isolated transistor input (sinking or sourcing)	<ul style="list-style-type: none"> <li>• ON: 8.8 VDC min./5 mA min.</li> <li>• OFF: 1.1 VDC max./0.5 mA max.</li> <li>• Connect to SELV</li> </ul>	<p>Configured as <b>Power ON/OFF</b> a signal change from inactive to active, will perform one of the following operations.</p> <ul style="list-style-type: none"> <li>• When powered ON, the Panel PC will shut down and power OFF.</li> <li>• When powered OFF, the Panel PC will power ON.</li> </ul>
5 6	Input 2 *3			<p>This input is provided to allow monitoring the state of an external UPS unit that provides a compatible power state output signal.</p>

\*1. Refer to *I/O Connector Output Details* on page 4-30 for Output 1 details.

\*2. Refer to *6-2 Power ON* on page 6-3 and *6-3 Power OFF* on page 6-5 for Power ON/OFF Input details.

\*3. This input is provided to allow monitoring the state of an external UPS unit that provides a compatible power state output signal.



### Additional Information

---

Refer to *5-4-4 Wire the I/O Connector* on page 5-41 for I/O connector wiring details.

---

## I/O Connector Output Details

This section provides details of Output 1.

Output 1 has a relay between pin 1 and 2 that can be used as a Power Status Output.



### Additional Information

Refer to 5-4-4 *Wire the I/O Connector* on page 5-41 for I/O connector wiring details.

### ● Power ON Output 1 Operation

This section provides power ON details of the Output 1 operation.

Output 1 turns ON to indicate that the system has been shut down and the power supply to the Panel PC can be turned OFF.

If power is not turned OFF, Output 1 will turn OFF when the Panel PC is turned ON.

Output 1 is ON <sup>(A)</sup> when the Panel PC has been used and has not been disconnected from the power supply.

Output 1 is OFF <sup>(B)</sup> when the Panel PC has been disconnected from the power supply.

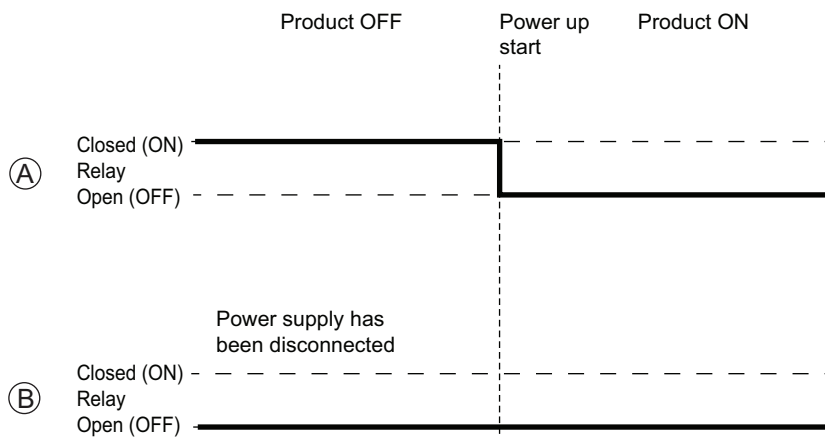

### ● Power OFF Output 1 Operation

This section provides power OFF details of the Output 1 operation.

Output 1 turns ON to indicate that the system has been shut down and the power supply to the Panel PC can be turned OFF.

If power is not turned OFF, Output 1 will stay ON <sup>(A)</sup>. It will turn OFF when the Panel PC is turned ON.

If power is turned OFF, Output 1 will turn OFF <sup>(B)</sup>.

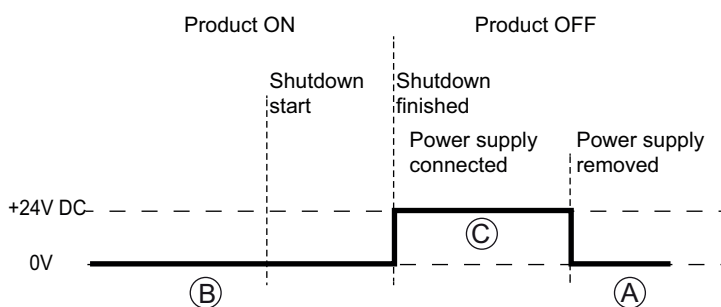

## Lock and Remove the I/O Connector

The I/O connector locks into place when the black part of the connector is held and pushed in to the I/O Port.

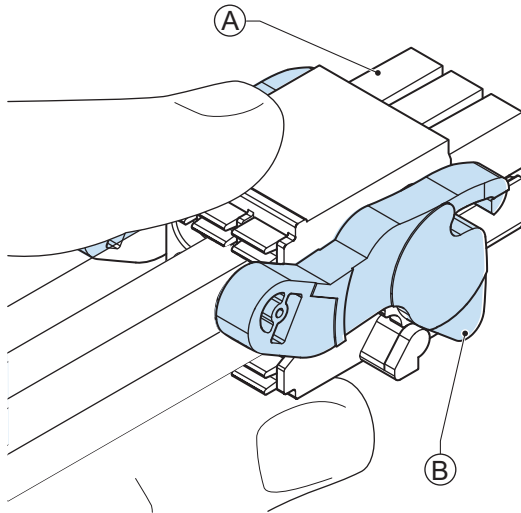

Tilting both levers **B** will release the I/O connector **A** from the Panel PC.

### 4-2-3 USB Connector Specifications

The Industrial Panel PC includes several USB connectors.  
 The connector layout represents the USB connectors on the Panel PC.

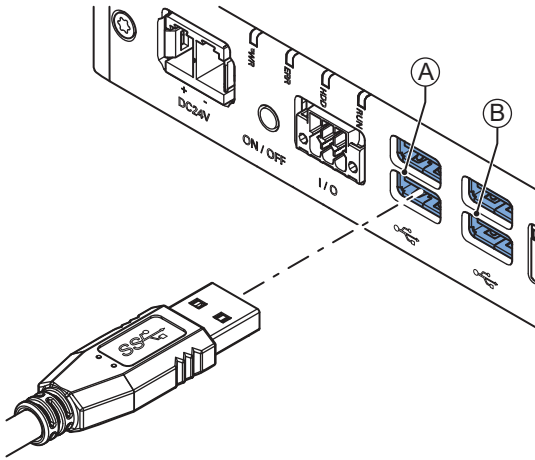

- (A)  
2 USB3.x connectors.
- (B)  
2 USB3.x connectors for model-IDs NY□13, NY□2E, NY□37, NY□55, NY□65.  
2 USB2.x connectors for all other model-IDs.

The power consumption is provided per USB Connector, calculate the sum for the maximum power consumption off all USB Connectors.

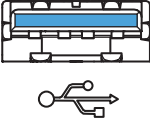
Interface	Details	Specification	Details
USB-A USB3.x		Maximum current	900 mA at 5V DC
		Maximum power consumption	4.5 W per USB connection
		Maximum cable length	3 m

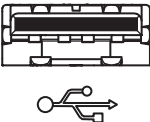
Interface	Details	Specification	Details
USB-A USB2.x		Maximum current	500 mA at 5V DC
		Maximum power consumption	2.5 W per USB connection
		Maximum cable length	5 m



#### Additional Information

Note that the read/write speed of the connected USB device determines the actual data transfer speed. Use a fast USB device to reduce data transfer durations.

## 4-2-4 Ethernet Connector Specifications

Details of the RJ45 Ethernet connectors are provided below.

The Ethernet connector locks automatically to prevent unintentional disconnection.

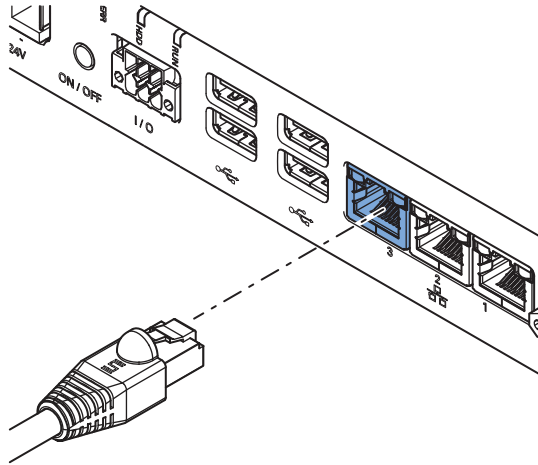

Base layer: 3 RJ45 connectors

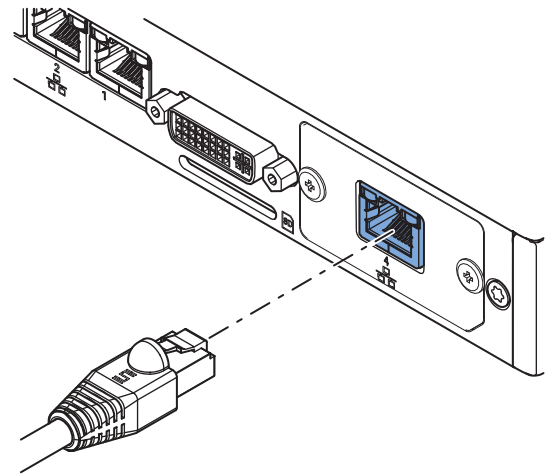

Base layer: 1 optional RJ45 connector

### Ethernet Connector Specification Details

Details of the RJ45 Ethernet connectors are provided below.

Item		Specifications
Physical layer	3 RJ45 connectors	10BASE-T, 100BASE-TX or 1000BASE-T 2500BASE-T *1
	1 optional RJ45 connector	1000BASE-T
Frame length		1,514 bytes max.
Media access method		CSMA/CD
Modulation		Baseband
Topology		Star
Transmission media		STP (shielded, twisted pair) cable of Ethernet category 5,5e or higher
Maximum transmission distance between Ethernet switch and node		100 m
Cascade connections		There are no restrictions if an Ethernet switch is used

\*1. For model-IDs NY□13, NY□2E, NY□37, NY□55, NY□65: the 3 RJ45 connectors support 2500BASE-T.  
For model-ID NY□3A: Ethernet connectors 2 and 3 support 2500BASE-T.

## Ethernet Connector LED Indicators

This section explains the RJ45 Ethernet connector LED indicators.

Each connector has LED indicators that display the link, activity and speed status.

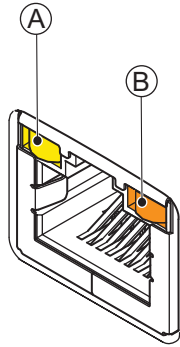

Item	Indicator	Color	Status		Description
A	Link/Act	Yellow		Not lit	No link
				Lit	Link
				Flashing	Link and activity
B	Speed	Not lit		Not lit	10 Mbps or no link
		Green		Lit	100 Mbps link
		Orange		Lit	1 or 2.5 Gbps link

## 4-2-5 DVI Connector Specifications

DVI is the standard video interface for the Panel PC.

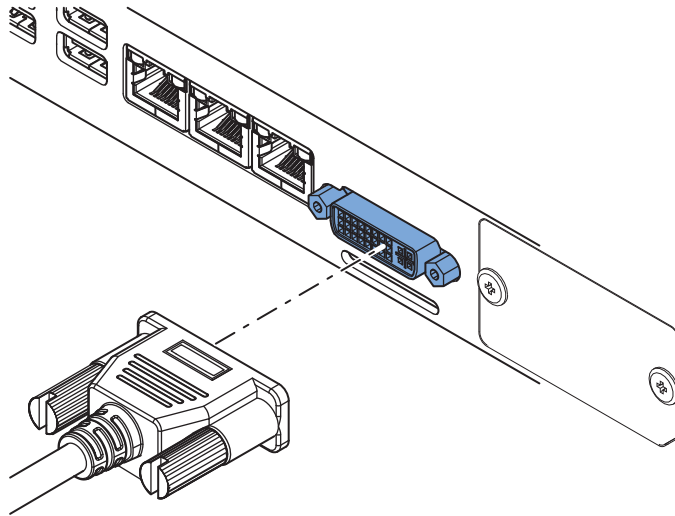

### Additional Information

- Refer to 4-1-5 *CPU Specifications* on page 4-10 for graphics controller details.
- Refer to 5-4-2 *Ground* on page 5-31 for grounding details.
- Refer to A-2 *DVI Connector Pin Details* on page A-76 for pin details.

The DVI Card specifications depend on the CPU and thus on the product configuration.

Item	Specifications
Video interface NY□1C	Digital only
Video interface NY□1E	Digital or Analog
Video interface NY□17	Digital or Analog
Video interface NY□2A	Digital only
Video interface NY□2C	Digital only
Video interface NY□25	Digital only
Video interface NY□27	Digital or Analog
Video interface NY□35	Digital only
Resolution	Up to 1920 x 1200 pixels at 60 Hz
Type	Dual link
Maximum DVI cable length	Dependent upon connected monitor type and resolution

## 4-2-6 DisplayPort Connector Specifications

The DisplayPort is the standard video interface for the Panel PC for model-IDs NY□13, NY□2E, NY□3A, NY□37, NY□55 and NY□65

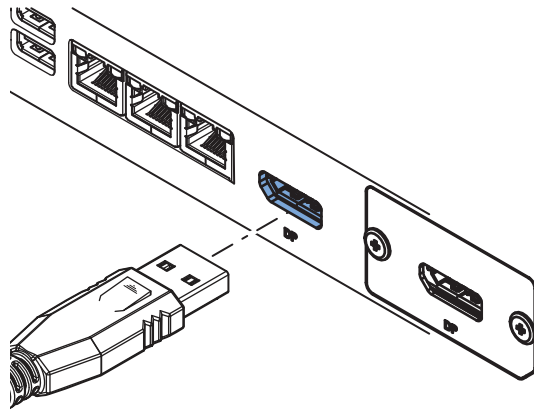

IPC left DisplayPort Connector

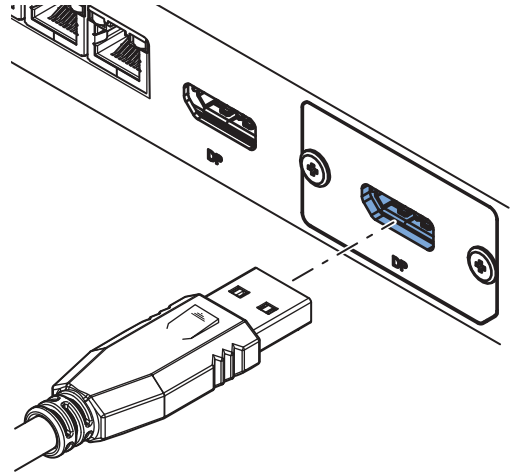

IPC right DisplayPort Connector



### Additional Information

Refer to *5-4-2 Ground* on page 5-31 for grounding details.

The DisplayPort specifications depend on the CPU and thus on the product configuration.

Item	Specifications
Video interface	Video and Audio
Version	1.2
Resolution	Up to 3840 x 2160 pixels at 75 Hz
Features	Multi-sst operation
Maximum DisplayPort cable length	Dependent upon connected monitor type and resolution.

The DisplayPort interface supports DP++ mode.

Make sure a thick, fully shielded, and high-resolution cable is used to prevent disturbance on the display. For DisplayPort cables that have a locking mechanism, press the release button on the connector to disconnect the cable.

A commercially available cable can be used to convert to a DVI-D, HDMI or VGA interface.

## 4-2-7 DVI-D Connector Specifications

The optional video interface on the Panel PC uses a DVI dual link connector.

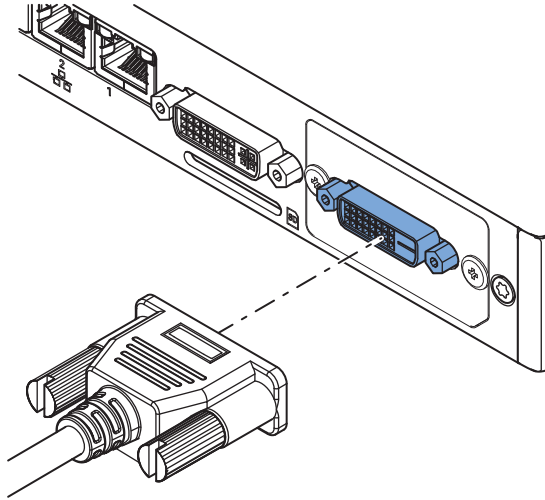

Item	Specification
Video interface	Digital only
Resolution	Up to 1920 x 1200 pixels at 60 Hz
Type	Dual link
Maximum DVI cable length	Dependent upon connected monitor type and resolution



### Additional Information

- Refer to *4-1-5 CPU Specifications* on page 4-10 for graphics controller details.
- Refer to *5-4-2 Ground* on page 5-31 for grounding details.
- Refer to *A-2-2 DVI-D Connector Pin Details* on page A-77 for pin details.

## 4-2-8 RS-232C Connector Specifications

The optional RS-232C interface on the Panel PC uses a standard SUBD9 connector. The RS-232C interface is not isolated from the internal Panel PC's components.

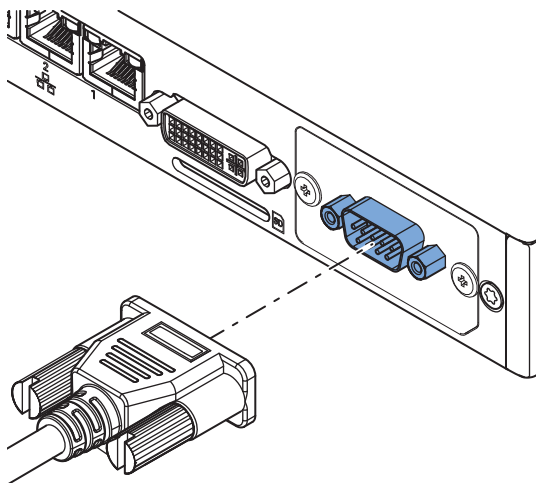

### Additional Information

- Refer to 5-4-2 *Ground* on page 5-31 for grounding details.
- Refer to A-3 *RS-232C Connector Pin Details* on page A-79 for pin details.

## 4-2-9 NY Monitor Link Connector Specifications

The NY Monitor Link connects an OMRON Industrial Monitor with an OMRON Industrial PC that has an NY monitor link connector.

The NY Monitor Link communication is a combination of video and USB information.

Item	Specifications
Connector type	RJ45
Transmission media	Twisted pair cable of category 6A or higher (double-shielded straight cable with copper braiding and aluminum foil) Refer to 3-10-7 <i>NY Monitor Link Cables</i> on page 3-32 for more information.
Maximum cable length between Industrial PC and Industrial Monitor	100 m
Topology	Line (direct) connection only *1
Video resolution	1,280 x 800 pixels at 60 Hz (12.1", 15.4") 1,920 x 1,080 pixels at 60 Hz (18.5")
USB Data throughput rate	280 Mbps max. *2
Daisy-chain functionality	Only for model-IDs: NY□13, NY□2E, NY□3A, NY□37, NY□55, NY□65

\*1. Use a direct NYML connection between the OMRON Industrial PC and the OMRON Industrial Monitor. Do not use Ethernet switches or Ethernet hubs.

\*2. Due to USB limitations it is advised to only connect Low- and Full-speed devices like keyboards and mice.

The NY Monitor Link connector locks automatically to prevent unintentional disconnection.

## NY Monitor Link Connector LED Indicators

The connector has LED indicators Connected (A) and Video (B).

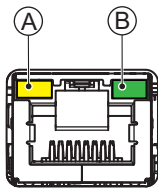

NYML

Item	Indicator	Color	Status		Description
A	Connected	Yellow		Not lit	Not connected
				Lit	Connected USB communication active
B	Video	Green		Not lit	No video signal
				Blinking	Video signal present
				Lit	Encrypted video signal present Video output is not supported for encrypted video.

## 4-3 Display Specifications

This section provides the display specifications of the Industrial Panel PC.

WARNING

Do not use the input functions of the touchscreen in applications that involve human life, in applications that may result in serious injury, or for emergency stop switches.





### Precautions for Correct Use

The touchscreen supports 5 simultaneous touches. When the number of touches is exceeded, not all touch points will be detected.

Item		Model Specifications		
		12.1 inch <sup>*1</sup>	15.4 inch <sup>*1</sup>	18.5 inch <sup>*1</sup>
Display panel <sup>*2</sup>	Display device	TFT LCD		
	Screen size	12.1 inch	15.4 inch	18.5 inch
	Surface treatment	Anti glare treatment		
	Surface hardness	Mohs scale 5-6		
	Resolution (horizontal × vertical)	1,280 × 800 pixels at 60 Hz		1,920 × 1,080 pixels at 60 Hz
	Colors	16,770,000 colors (24 bit full color)		
	Effective display area	261 × 163 mm (horizontal × vertical)	331 × 207 mm (horizontal × vertical)	409 × 230 mm (horizontal × vertical)
	View angles	Left: 60°, Right: 60°, Top: 60°, Bottom: 60°		Left: 89°, Right: 89°, Top: 89°, Bottom: 89°
	EMC	Correct touchscreen operation is possible within allowable EMC immunity conditions <sup>*3</sup>		
Touch	Technology	Projected capacitive		
	Touch resolution	Touch accuracy 1.5% (4-5mm)		
	Life	50,000,000 operations minimum		
	Multitouch	Up to 5 simultaneous touches		
	Features	Water detection <sup>*4</sup> , hand palm rejection <sup>*5</sup> , gloves <sup>*6</sup>		
Backlight	Life	50,000 hours minimum. <sup>*7</sup>		
	Brightness adjustment <sup>*8</sup>	200 levels		

<sup>\*1.</sup> Refer to *1-4 Product Configuration Panel PC* on page 1-5 for details.

<sup>\*2.</sup> There may be some defective pixels in the display. This is not a fault as long as the number of defective light and dark pixels fall within the following standard range: light and dark pixels 10 or less. There must not be 3 adjacent light/dark pixels.

<sup>\*3.</sup> Refer to *4-1-2 General Electrical Specifications* on page 4-6 for EMC immunity level specifications.

<sup>\*4.</sup> Details are available in **Touch input settings** of the Industrial Monitor Utility.

See NY-series Operating Systems and Software Utilities Manual (Cat. No. W616).

- \*5. If a palm is detected that specific area is ignored.
- \*6. The touchscreen can be operated when wearing gloves. Confirm you can operate the touchscreen with gloves before actual operation.
- \*7. This is the estimated time before brightness is reduced by half at room temperature. The life expectancy is drastically shortened if used at high temperatures.
- \*8. If the brightness is set to very low, it causes flickering or the screen will be too dark to use.

All LCD displays will display image retention effects when used in less optimal conditions. Refer to *7-1-5 Minimize LCD Image Retention* on page 7-4 for details.

## 4-4 Environmental Specifications

This section provides environmental specifications of the Industrial Panel PC.

### 4-4-1 Operation Environment Specifications

The following table provides general environmental specifications for the Industrial Panel PC.

Item	Specifications		
	12.1 inch <sup>*1</sup>	15.4 inch <sup>*1</sup>	18.5 inch <sup>*1</sup>
Ambient operating temperature	0 to 55°C <sup>*2</sup>		
Ambient storage temperature	-20 to 70°C <sup>*2</sup>		
Ambient operating humidity	10% to 90% (with no condensation) <sup>*2</sup>		
Ambient storage humidity	10% to 90% (with no condensation) <sup>*2</sup>		
Operating atmosphere	No corrosive gases		
Altitude	2,000 m max.		
Noise resistance (during operation)	Conforms to IEC 61000-4-4, 2kV (power lines)		
Vibration resistance (during operation)	The vibration resistance depends on the storage device(s): <ul style="list-style-type: none"> <li>• For a Panel PC with only SSD storage devices: 5 to 8.4Hz with 3.5 mm single amplitude and 8.4 to 150 Hz with 9.8 m/s<sup>2</sup> for 10 times each in X, Y and Z directions. Conforms to IEC 60068-2-6.</li> <li>• For a Panel PC with one or more HDD storage devices the Panel PC must be installed in a vibration free environment. <sup>*3</sup></li> </ul>		
Shock resistance (during operation)	Conforms to IEC 60068-2-27. 147 m/s <sup>2</sup> , 3 times each in X, Y and Z directions		
Material finish	Applicable for model-ID NYP□□-□□□□□-□□□□□1□□ <sup>*1</sup> Nickel plated conforms to ASTM B733-15, SC2		
Degree of protection	Front of Monitor: IP65 or the equivalent <sup>*4</sup>		
Pollution degree	JIS B3502 and IEC 61131-2: 2 or less		

\*1. Refer to Product Configuration Panel PC for details.

\*2. Refer to *4-4-2 Temperature and Humidity Specifications* on page 4-43 for ambient operating temperature and humidity details per CPU type.

\*3. A Panel PC with one or more HDD storage devices should not be used in applications subject to vibration. Examples of applications subject to vibration:

- AGV (Automated Guided Vehicles)
- Rail vehicle
- Stacker crane
- Elevator
- Tableting machine
- Connector pin assembling machine
- Bending machine

Ensure your Panel PC with HDD does not vibrate. When in doubt use a Panel PC with SSD storage devices.

\*4. The Panel PC may not operate properly in locations subjected to oil splashes for extended periods of time.

## 4-4-2 Temperature and Humidity Specifications

The maximum ambient operating temperature depends on the model, mounting orientation, and storage device type.

The following tables provide ambient temperature and humidity details and temperature specifications per model.

### Operating Temperature and Humidity Graphs

The maximum ambient operating temperature and ambient humidity are specified per storage device type.

The following graphs provide ambient temperature and humidity details per storage device type and the conditions for storage.

- Operate the Panel PC with a HDD within the ambient temperature and humidity ranges as shown in following graph.

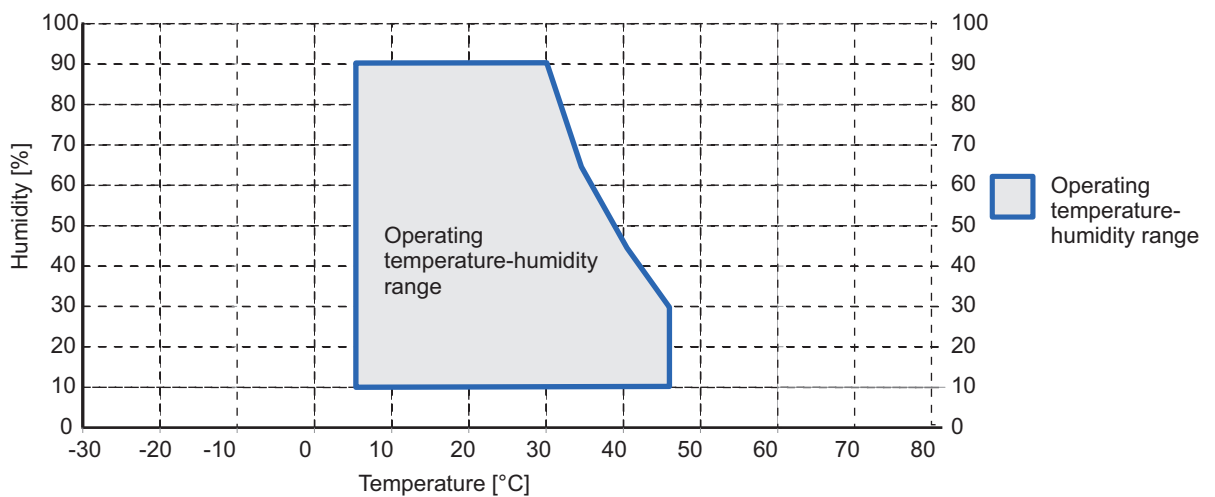

#### Additional Information

Refer to the ambient temperature specifications per Model-ID for ambient operating temperature details.

- Operate the Panel PC with a SSD or CFast within the ambient temperature and humidity ranges as shown in following graph.

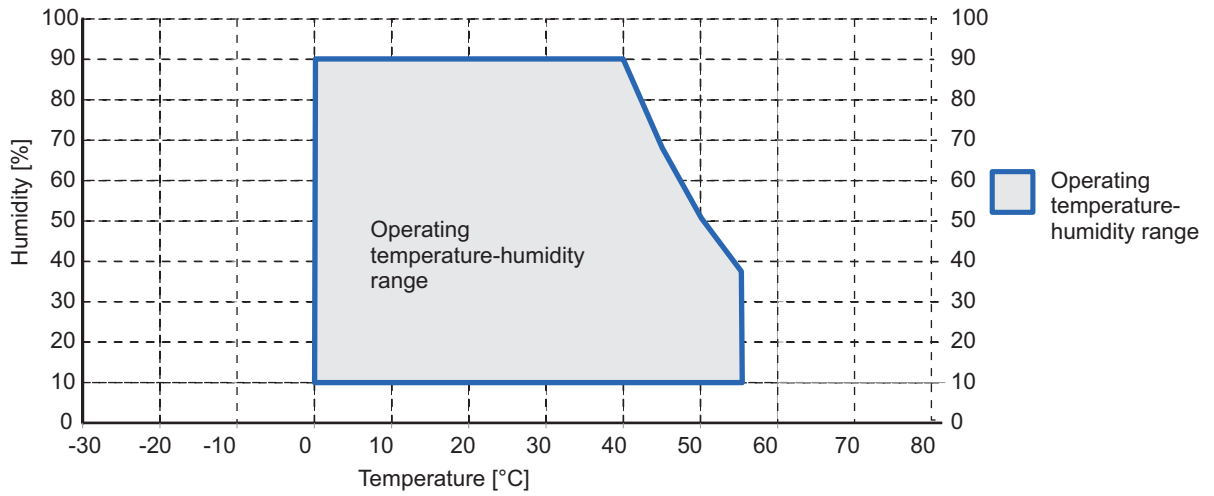

Model-ID	Specifications
<ul style="list-style-type: none"> <li>• NYP13-□0</li> <li>• NYP2A-□0</li> <li>• NYP2C-□0</li> <li>• NYP3A-□0</li> <li>• NYP35-□0</li> <li>• NYP65-□0</li> </ul>	Refer to <i>Temperature Specifications Without Expansion and Passive Cooling</i> on page 4-46 for more information.
<ul style="list-style-type: none"> <li>• NYP27-□0</li> <li>• NYP37-□0</li> <li>• NYP55-□0</li> </ul>	Refer to <i>Temperature Specifications Without Expansion and Active Cooling</i> on page 4-47 and active cooling for more information.
<ul style="list-style-type: none"> <li>• NYP1C-□1</li> <li>• NYP13-□1</li> <li>• NYP2C-□1</li> <li>• NYP25-□1</li> <li>• NYP35-□1</li> <li>• NYP65-□1</li> </ul>	Refer to <i>Temperature Specifications With Expansion and Passive Cooling</i> on page 4-47 for more information.
<ul style="list-style-type: none"> <li>• NYP17-□1</li> <li>• NYP27-□1</li> </ul>	Refer to <i>Temperature Specifications With Expansion and Active Cooling</i> on page 4-48 for more information.

## Storage Temperature and Humidity Graphs

The maximum ambient storage temperature and ambient humidity are specified per storage device type.

The following graph provides ambient storage temperature and humidity details per storage device type.

- Store the Panel PC with a SSD or CFast within the general environmental specifications.
- Store the Panel PC with a HDD within the ambient temperature and humidity ranges as shown in following graph.

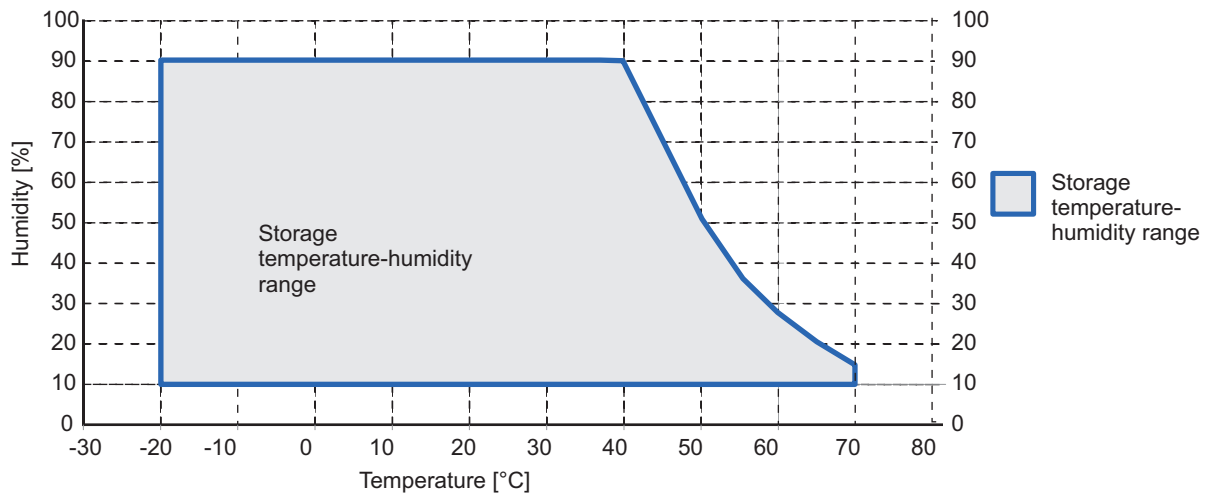

## Temperature Specifications Without Expansion and Passive Cooling

Ambient operating temperature specifications for Panel PCs without an expansion layer and with a passive cooling layer.

Product Orientation	Mounting Angle	Storage device type <sup>*1</sup>
		CFast Card
Landscape and Portrait	0° to 45°	0 to 50°C <sup>*2</sup>
Landscape	45° to 90°	0 to 55°C <sup>*3</sup>
	90° to 135°	0 to 55°C <sup>*3</sup>
Portrait	45° to 90°	0 to 55°C <sup>*3</sup>
	90° to 135°	0 to 55°C <sup>*3</sup>

\*1. Refer to *1-4 Product Configuration Panel PC* on page 1-5 for model details.

\*2. 45°C for model NYP65-□0

\*3. 50°C for model NYP65-□0

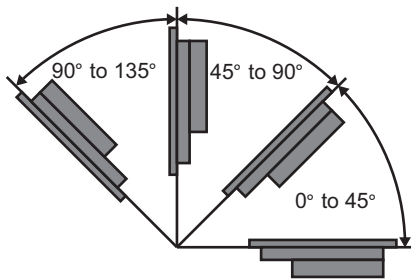

## Temperature Specifications Without Expansion and Active Cooling

Ambient operating temperature specifications for Panel PCs without an expansion layer and with an active cooling layer.

Product Orientation	Mounting Angle	Storage device type <sup>*1</sup>
		SSD
Landscape and Portrait	0° to 135°	0 to 55°C

\*1. Refer to 1-4 Product Configuration Panel PC on page 1-5 for model details.

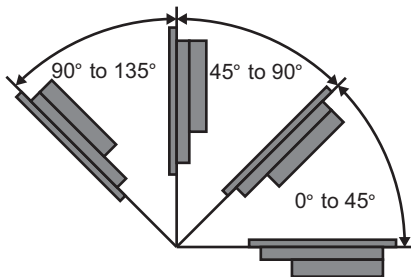

## Temperature Specifications With Expansion and Passive Cooling

Ambient operating temperature specifications for models with an expansion layer and with a passive cooling layer.

Product Orientation	Mounting Angle	Configuration <sup>*1</sup>		
		1 or 2 x SSD	1 x HDD 320 GB / 500 GB	1 x HDD 1 TB
Landscape and Portrait	0° to 45°	0 to 50°C <sup>*2</sup>	5 to 35°C	0 to 30°C
Landscape	45° to 90°	0 to 55°C <sup>*3</sup>	5 to 35°C	0 to 35°C
	90° to 135°	0 to 55°C <sup>*3</sup>	5 to 40°C	0 to 35°C
Portrait	45° to 90°	0 to 55°C <sup>*3</sup>	5 to 40°C	0 to 35°C
	90° to 135°	0 to 55°C <sup>*3</sup>	5 to 40°C	0 to 35°C

\*1. Refer to 1-4 Product Configuration Panel PC on page 1-5 for model details.

\*2. 45°C for models NYP2C-□1, NYP35-□1, NYP65-□1.

\*3. 45°C for model NYP65-□1.

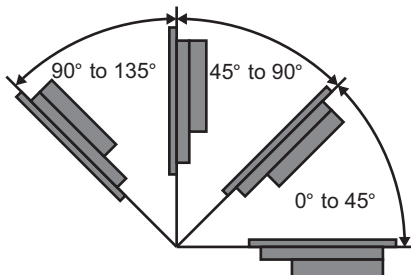

## Temperature Specifications With Expansion and Active Cooling

Ambient operating temperature specifications for models with an expansion layer and with an active cooling layer.

Product Orientation	Mounting Angle	Configuration <sup>*1</sup>		
		1 or 2 x SSD	1 x HDD 320 GB / 500 GB	1 x HDD 1 TB
Landscape and Portrait	0° to 45°	0 to 50°C	5 to 35°C	0 to 35°C <sup>*2</sup>
Landscape	45° to 90°	0 to 55°C	5 to 35°C	0 to 35°C <sup>*3</sup>
	90° to 135°	0 to 55°C	5 to 40°C	0 to 40°C <sup>*3</sup>
Portrait	45° to 90°	0 to 55°C	5 to 40°C	0 to 40°C <sup>*3</sup>
	90° to 135°	0 to 55°C	5 to 40°C	0 to 40°C <sup>*3</sup>

\*1. Refer to 1-4 Product Configuration Panel PC on page 1-5 for model details.

\*2. 0 to 30°C for model NYP27-□1

\*3. 0 to 35°C for model NYP27-□1

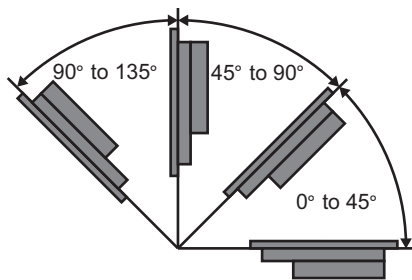

### 4-4-3 Recycling Specifications

The following table provides recycling information for the Industrial Panel PC.

Part	Recycle specifications
Battery	Chemical waste
Other electrical components	Electrical waste



#### Precautions for Safe Use



廢電池請回收

Dispose of the product and batteries according to local ordinances as they apply.



Dispose in accordance with applicable regulations.

# 5

## Installation

This section provides all installation details for the Industrial Panel PC.

<b>5-1</b>	<b>Unpack .....</b>	<b>5-2</b>
5-1-1	Unpack Procedure.....	5-2
5-1-2	Items Supplied.....	5-3
<b>5-2</b>	<b>Install Options .....</b>	<b>5-4</b>
5-2-1	Install a Drive.....	5-4
5-2-2	Install the PCIe Card .....	5-8
<b>5-3</b>	<b>Mount.....</b>	<b>5-14</b>
5-3-1	Installation Method in Control Panels.....	5-14
5-3-2	Product Orientation .....	5-15
5-3-3	Temperature .....	5-16
5-3-4	Humidity .....	5-18
5-3-5	Vibration and Shock .....	5-18
5-3-6	Atmosphere .....	5-19
5-3-7	Electrical Environment.....	5-19
5-3-8	Panel Mount Procedure.....	5-25
5-3-9	VESA Mount Procedure .....	5-28
<b>5-4</b>	<b>Wire.....</b>	<b>5-31</b>
5-4-1	Wiring Warnings and Cautions .....	5-31
5-4-2	Ground .....	5-31
5-4-3	Wire the Power Connector .....	5-38
5-4-4	Wire the I/O Connector.....	5-41
<b>5-5</b>	<b>Connect.....</b>	<b>5-44</b>
5-5-1	Connector Identification.....	5-44
5-5-2	Connection Procedure.....	5-46
<b>5-6</b>	<b>Initial Power ON.....</b>	<b>5-48</b>
5-6-1	Initial Power ON Procedure.....	5-48
5-6-2	Windows Startup First Time .....	5-50
<b>5-7</b>	<b>Install Software.....</b>	<b>5-52</b>
<b>5-8</b>	<b>Connect UPS .....</b>	<b>5-53</b>
5-8-1	Connect UPS Using the USB Connector .....	5-54
5-8-2	Connect UPS Using the I/O Connector .....	5-56
<b>5-9</b>	<b>Create Backup and Repair Data.....</b>	<b>5-60</b>

# 5-1 Unpack

---

This section provides details on how to unpack the Industrial Panel PC.

## 5-1-1 Unpack Procedure

- 1** Check the package for damage.  
If there is any visible damage:
  - Take photos of the package and save them.
  - Inform your supplier immediately.
- 2** Open the package.  
Ensure not to damage the contents.
- 3** Ensure that all items are present.



---

### Additional Information

Refer to *5-1-2 Items Supplied* on page 5-3 for the items supplied.

---

## 5-1-2 Items Supplied

This section describes the items supplied with your Industrial Panel PC.

- Industrial Panel PC
- Documentation:
  - Safety Precautions sheets (English and Japanese)
  - General Compliance Information and Instructions for EU
  - Standards and Certifications sheet
- Bag with:
  - Power connector
  - I/O connector
- Models with an Expansion Layer will have inside the bag also:
  - Drive bracket for drive installation
  - 4 Mounting screws for drive installation
  - PCIe Card support for PCIe Card installation

Model NYP□□-□1.

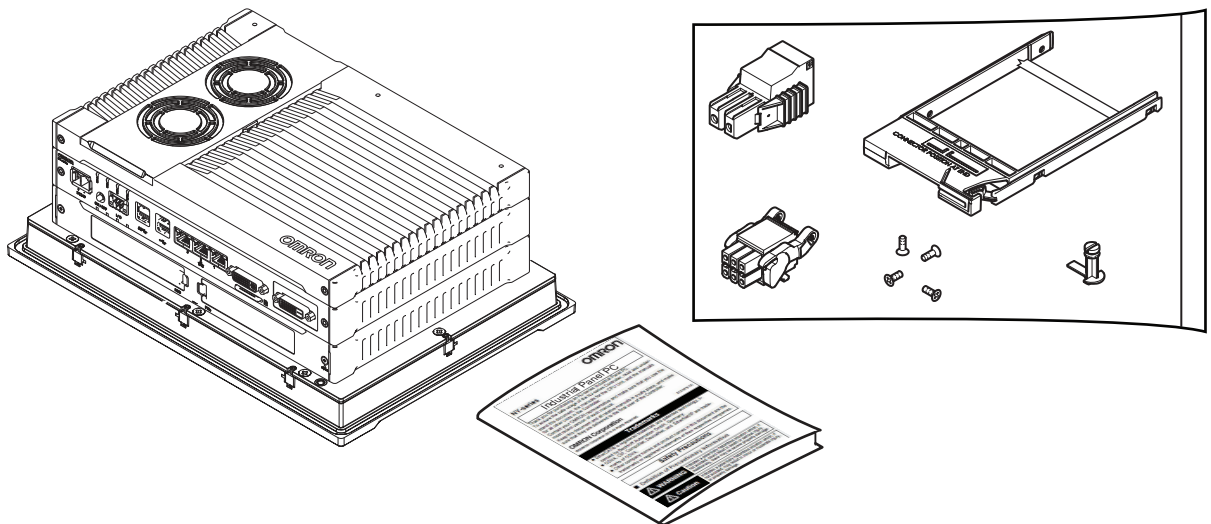

Model NYP□□-□0.

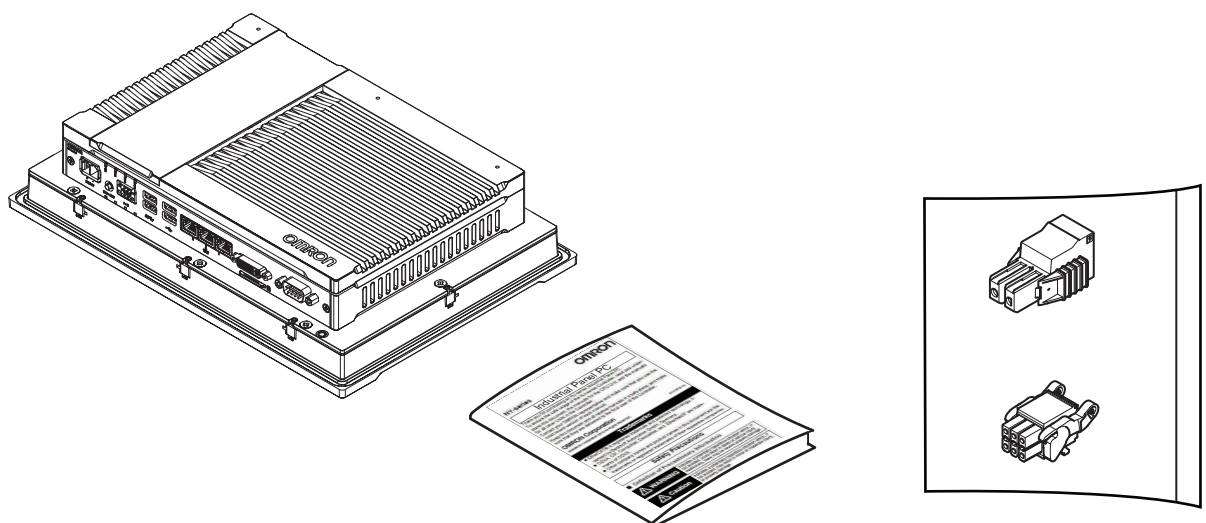

## 5-2 Install Options

This section describes the installable options for the Industrial Panel PC.

### 5-2-1 Install a Drive

A drive is a storage device for the Industrial Panel PC.



#### Additional Information

- Depending on the product configuration 0, 1 or 2 drives can be pre-installed. Refer to *1-4 Product Configuration Panel PC* on page 1-5 for details.
- Depending on the CPU type one or two drives are supported. Refer to *4-1-5 CPU Specifications* on page 4-10 for the number of supported drives.
- Refer to *3-10-4 HDD and SSD Storage Devices* on page 3-29 for the recommended drive models.
- Refer to *4-1-7 Storage Device Specifications* on page 4-17 for drive specifications.

Prepare the following items:

- The drive  
A drive is not supplied with the Panel PC.
- The drive bracket with mounting screws  
These are supplied with the Panel PC.

To install a drive:

- 1** Ensure the Panel PC is OFF.
- 2** Remove the drive cover.

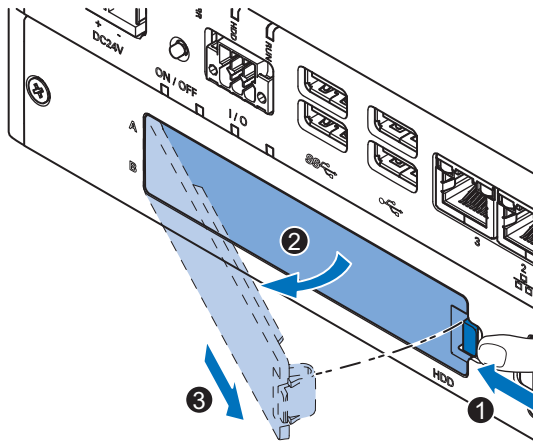

- 1) Push the lock lever **1**.
- 2) Tilt the drive cover **2**.
- 3) Remove the drive cover **3**.

- 3** Pull the metal shielding cover out of the Panel PC.

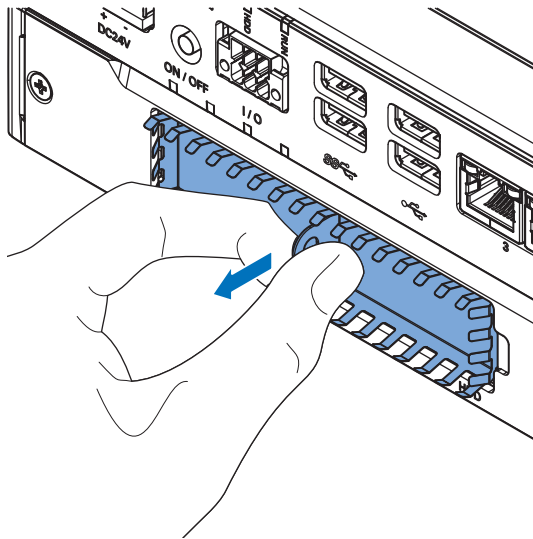

- 4** Rotate **1** and then remove **2** the break out part from the drive bracket.

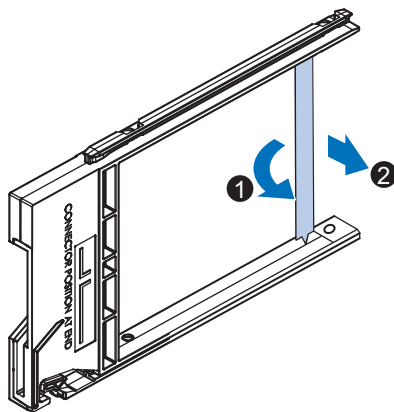

- 5** Align the connectors of the drive as shown **(A)** on the bracket. Then insert the replacement drive **1** in the bracket and insert the 4 mounting screws **2**. Tighten these screws with a torque of 0.35 N·m.

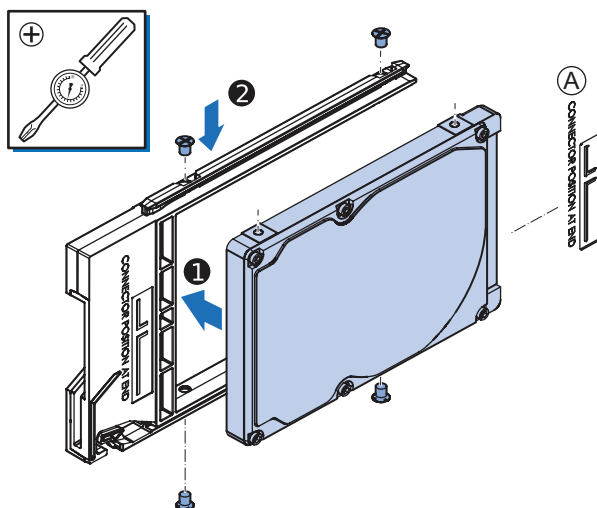

- 6** Insert the bracket with the drive in the correct bay.  
Refer to *3-1-3 Expansion Layer (Optional)* on page 3-6 for bay details.

Ensure the bracket is completely in the Panel PC with an extra push.

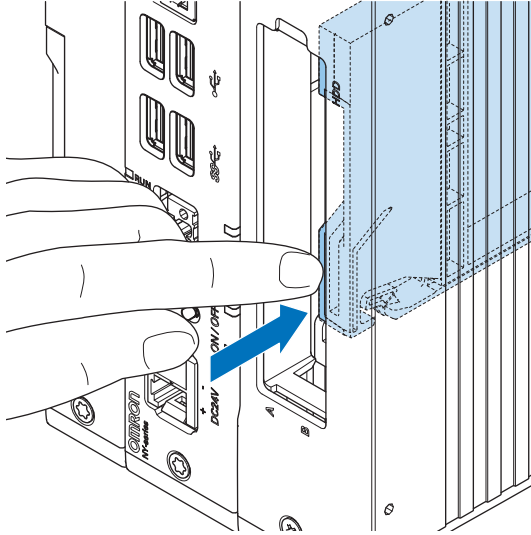

The drive bracket will lock into place when it is fully inserted.

- 7** Insert the metal shielding cover.

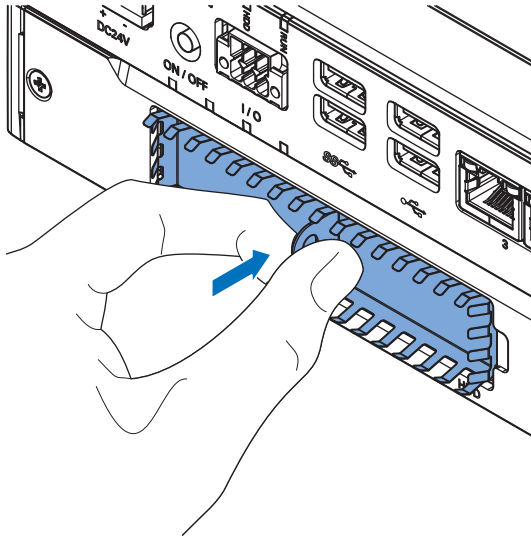

- 8** Mount the drive cover.  
The lock lever will click when closed correctly.

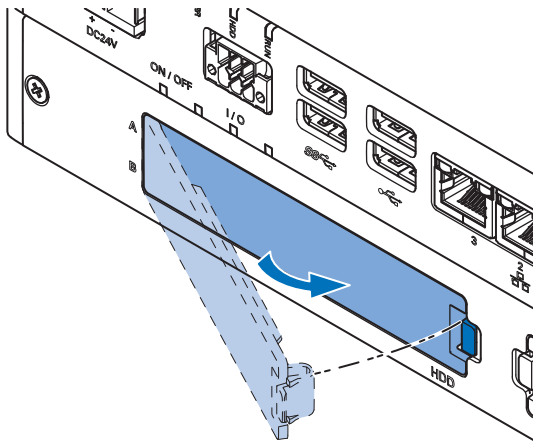

- 9** Finalize the drive installation when the Panel PC installation is completed.
- For a drive that requires an operating system:
    - 1) Install an operating system
    - 2) Power OFF and then Power ON
    - 3) Ensure the drive is functional and confirm normal operation.  
If required set the drive as boot disk in the BIOS settings.  
Refer to A-1 BIOS on page A-2 for boot priority settings.
  - For storage drives:
    - 1) Ensure the drive is functional and confirm normal operation.
    - 2) For a Panel PC with a Windows operating system:  
If the storage drive should be visible in Windows but it is not visible then that drive needs to be allocated.  
Refer to 3-1-3 Expansion Layer (Optional) on page 3-6 for details on the visibility per storage drive.

The drive is installed and functional.

## 5-2-2 Install the PCIe Card

Prepare the following items:

- The PCIe Card.

A PCIe Card is not supplied with the Panel PC.



### Additional Information

- Depending on the product configuration a PCIe card can be pre-installed. Refer to *1-4 Product Configuration Panel PC* on page 1-5 for details.
- Refer to *4-1-8 PCIe Card Specifications* on page 4-21 for PCIe specifications.

- The PCIe Card mounting material: Card Support.

This item is supplied with the Panel PC.

To install the PCIe Card:

- 1** Ensure the Panel PC is OFF.
- 2** Remove the two crosshead screws **1** indicated with "open" and then pull up **2** the PCIe Drawer.

The indent at the side of the drawer will help you to pull the drawer from the Panel PC.

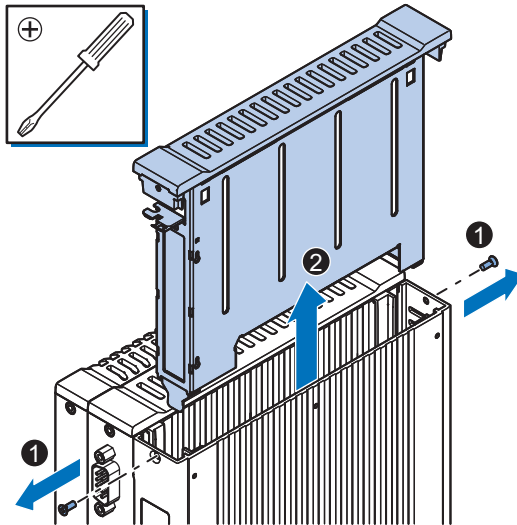

- 3** Remove the Card Clip from the PCIe Drawer.  
There are two types of Card Clips available. Use the steps applicable to your type.

## CAUTION

When installing or removing a PCIe card, avoid touching the sharp edges of the sheet metal frame tab. Injury may result.

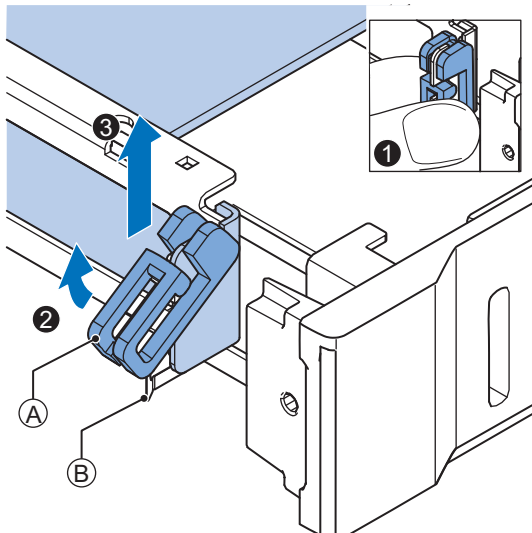

(A) Card Clip

(B) Sheet metal frame tab

Grip the Card Clip (A) on the sides ①. Pull the middle of the Card Clip to unlock it ② and remove it ③ from the PCIe Drawer.

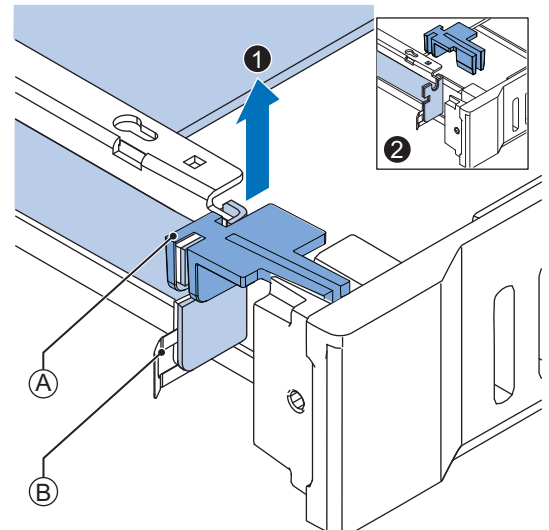

(A) Card Clip

(B) Sheet metal frame tab

Grip the Card Clip (A) on the sides. Lift the Card Clip ① and remove it ② from the PCIe Drawer.

- 4** Remove the slot cover from the PCIe Drawer.  
The thin sheet metal frame should stay in the PCIe Drawer.

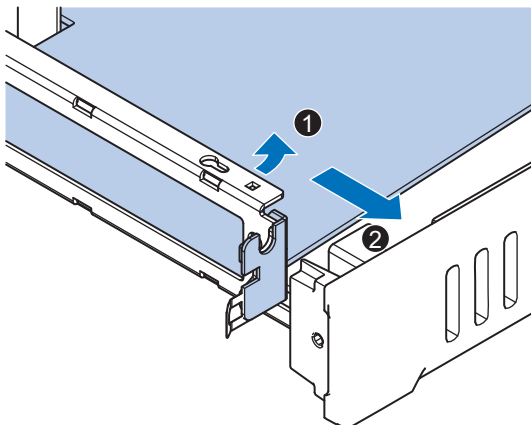

The slot cover is now removed.

**5** Place the PCIe Card in the PCIe Drawer.

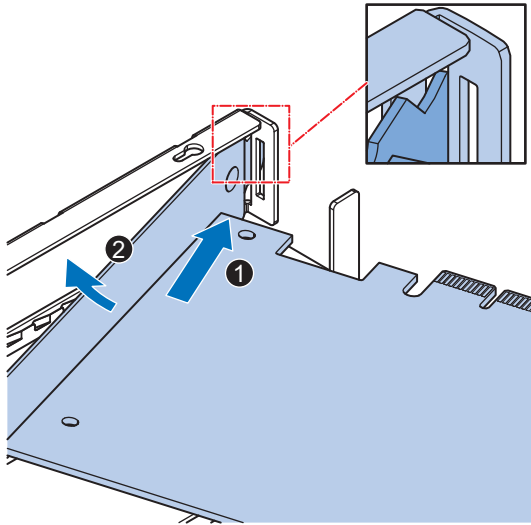

Ensure to insert the PCIe Card in the correct opening.

Ensure the thin sheet metal frame is positioned between the PCIe Card and the PCIe Drawer to ensure a good conductive contact.

## 6 Place the Card Clip (A) in the PCIe Card and PCIe Drawer.

There are two types of Card Clips available. Use the steps applicable to your type.

### CAUTION

When installing or removing a PCIe card, avoid touching the sharp edges of the sheet metal frame tab. Injury may result.

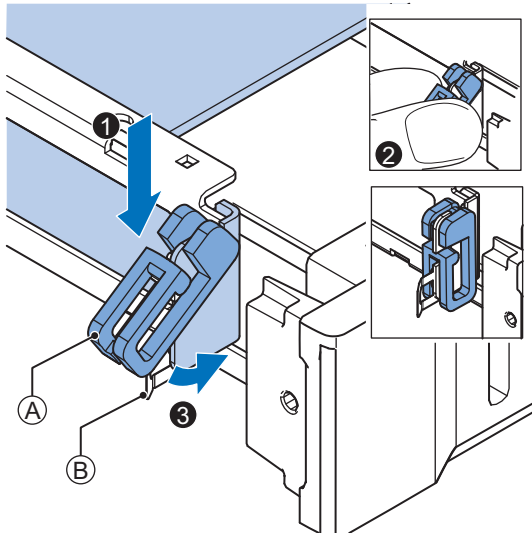

(A) Card Clip

(B) Sheet metal frame tab

Place the Card Clip (A) in the PCIe Card and PCIe Drawer (1), grip the Card Clip on the sides (2) and then rotate the Clip (3) to lock it in place.

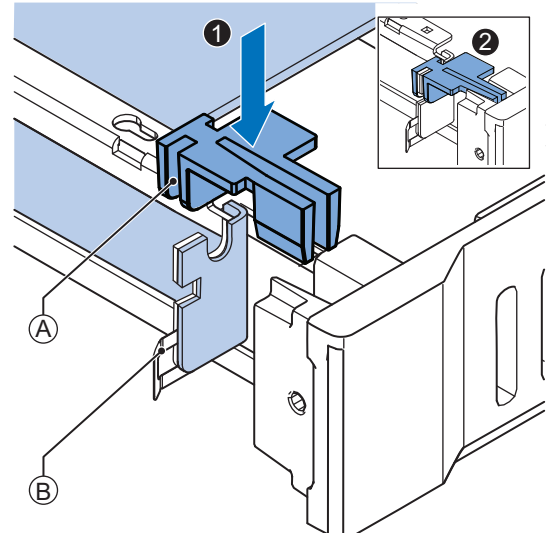

(A) Card Clip

(B) Sheet metal frame tab

Place the Card Clip (A) in the PCIe Card and PCIe Drawer and push it down (1) to lock it in place (2).

- 7** Slide the Card Support **1** so that it supports the side of the PCIe Card.  
The card should be in small groove so there is support below and above the card.  
Rotate the Card Support **2** to lock it in place.

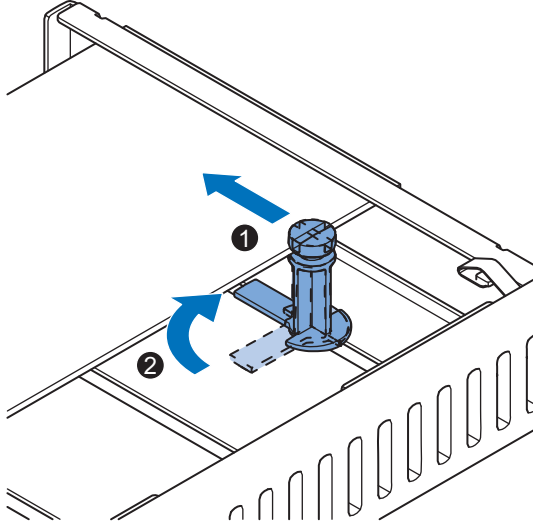

- 8** Insert the PCIe Drawer in the Panel PC and then insert the two crosshead screws that hold the PCIe Drawer in place.

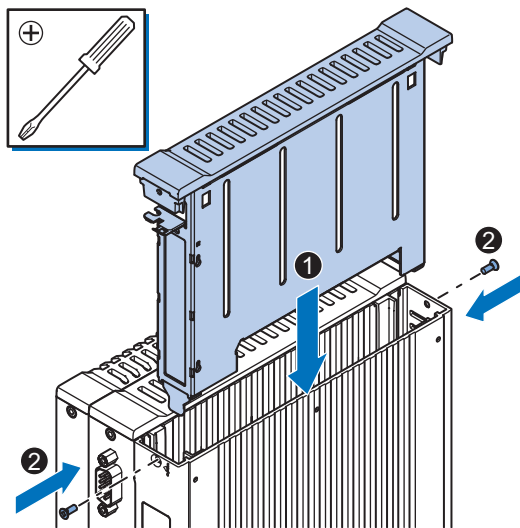

- 9 Remove the PCIe cover if the PCIe Card has external connectors.

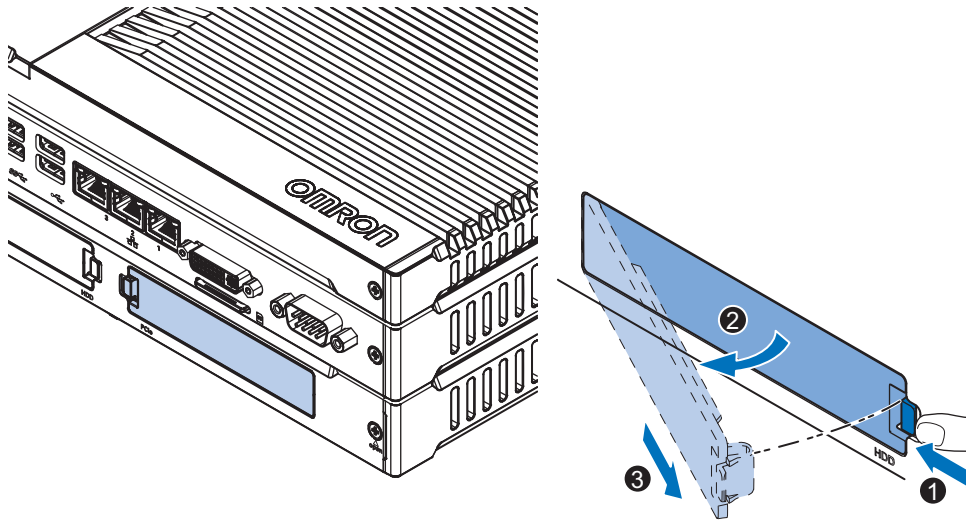

- 1) Push the lock lever ①.
- 2) Tilt the PCIe cover ②.
- 3) Remove the PCIe cover ③.

The PCIe Card is installed.

## 5-3 Mount

This section describes how to mount the Industrial Panel PC in a control panel.

### **WARNING**

Ensure that installation and post-installation checks of the product are performed by personnel in charge who possess a thorough understanding of the machinery to be installed.



### 5-3-1 Installation Method in Control Panels

The Panel PC must be mounted to the outside surface of a control panel.

Consider product orientation, cooling distance, noise resistance, ducts and product replacement when determining the space between the Panel PC and other devices.



#### **Precautions for Safe Use**

Install the product in the correct orientation and temperature according to the specifications in the manual to prevent overheating. Not doing so may result in malfunction.



#### **Precautions for Correct Use**

Do not operate or store the product in the following locations. Operation may stop or malfunctions may occur.

- Locations subject to direct sunlight
- Locations subject to temperatures or humidity outside the range specified in the specifications
- Locations subject to condensation as the result of severe changes in temperature
- Locations subject to corrosive or flammable gases
- Locations subject to dust (especially iron dust) or salts
- Locations subject to exposure to water, oil or chemicals
- Locations subject to shock or vibration
- Locations outdoors subject to direct wind and rain
- Locations subject to strong ultraviolet light



#### **Additional Information**

- Ensure you have installed the options before you mount the product. Refer to *5-2 Install Options* on page 5-4 for option details.
- Refer to *5-3-2 Product Orientation* on page 5-15 for orientation details.
- Refer to *5-3-3 Temperature* on page 5-16 for temperature details.
- Refer to *5-3-4 Humidity* on page 5-18 for humidity details.
- Refer to *5-4 Wire* on page 5-31 for wiring details.

### 5-3-2 Product Orientation

The Industrial Panel PC can be mounted in a landscape (A) or portrait (B) orientation.

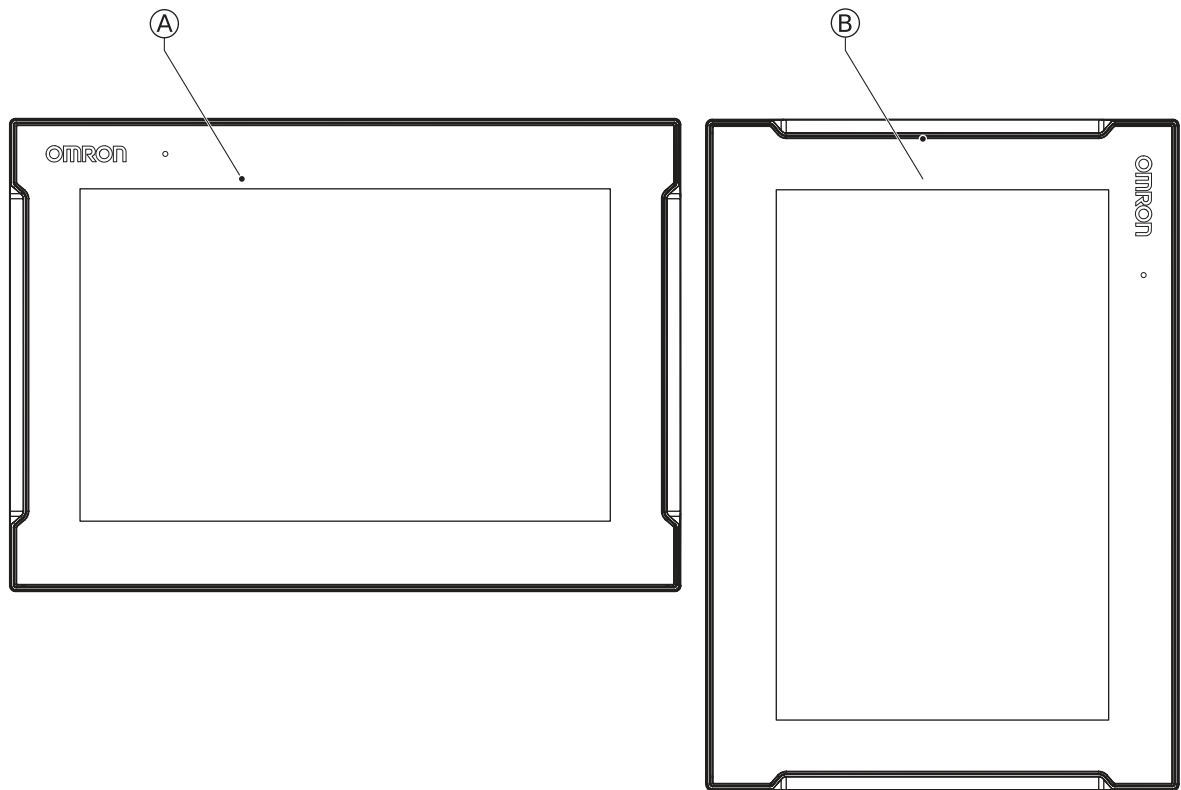

Do not install the Industrial Panel PC in any of the following orientations.

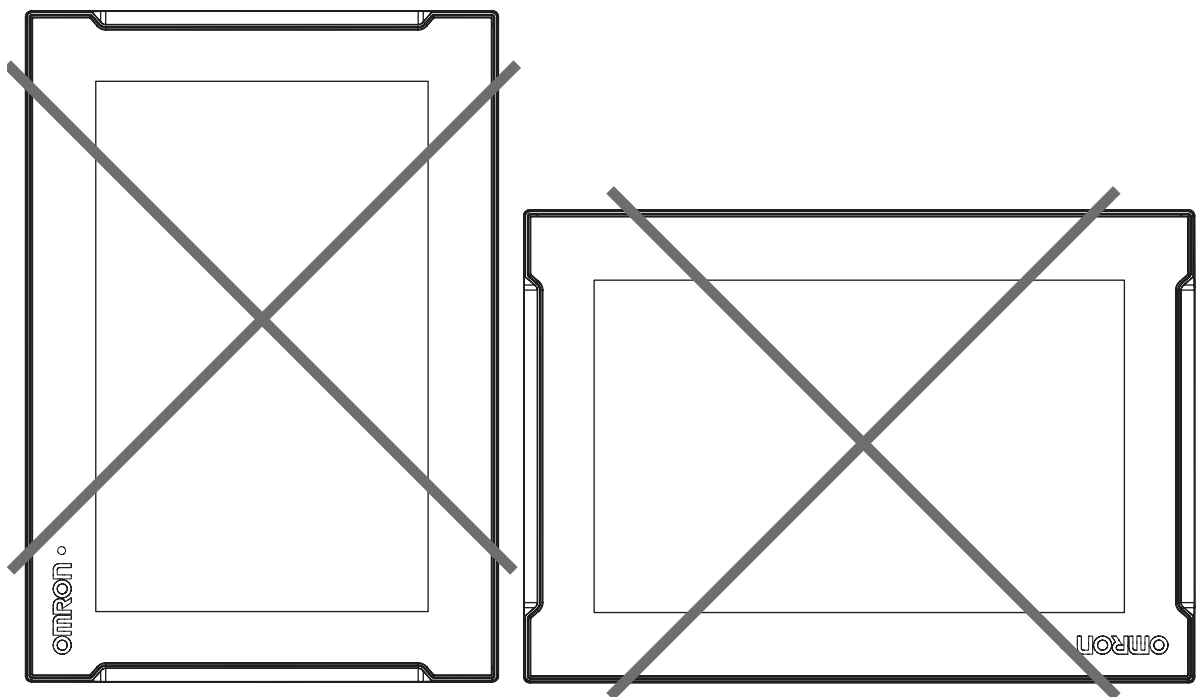

### 5-3-3 Temperature

#### Distance for Cooling

Adequate airflow around the Industrial Panel PC is required.



#### Additional Information

- The ambient temperature must be within the operating range. Refer to *4-4-1 Operation Environment Specifications* on page 4-42 for temperature specifications.
- Allow space to accommodate for the bending radius of the cables. Refer to *3-10 Optional Hardware* on page 3-27 for cable bending requirements and connector clearances.

Provide enough space for good air flow and ensure the following minimum distances are observed around the sides of the Industrial Panel PC.

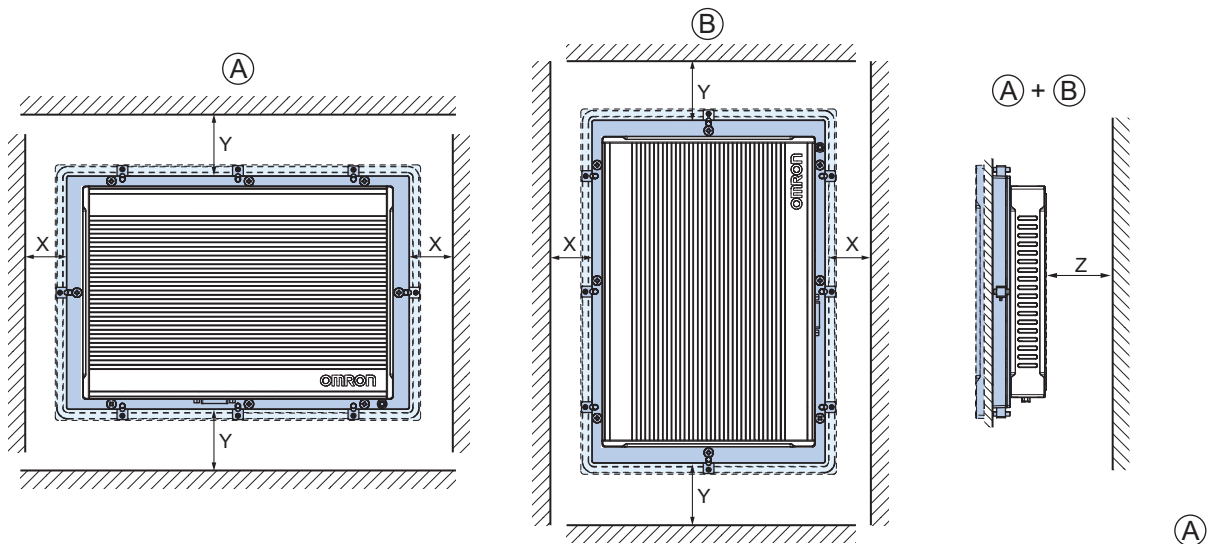

Landscape orientation. (B) Portrait orientation.

Item	Minimum distance
X	50 mm
Y	100 mm
Z	50 mm

## High Temperatures

Use the following cooling methods as required, taking into account the ambient temperature and the amount of heating inside the panel.

### ● Natural Cooling

Natural cooling relies on natural ventilation through slits in the panel, rather than using cooling devices such as fans or coolers. When using this method, observe the following points.

- Do not install the Panel PC at the top of the panel, where hot air tends to stagnate.
- To provide ventilation space above and below the Panel PC, leave sufficient distance from other devices, wiring ducts, etc.
- Do not mount the Panel PC in the wrong direction (e.g., vertically or upside down). Doing so may cause abnormal heating in the Panel PC.
- Do not install the Panel PC directly above any heat-generating equipment, such as heaters or transformers.
- Do not install the Panel PC in a location exposed to direct sunlight.

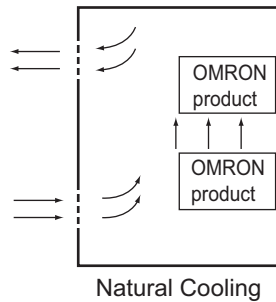

### ● Forced Ventilation

Forced ventilation with a fan in the top of the control cabinet.

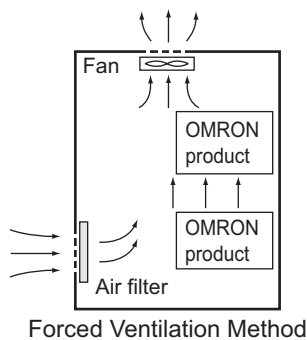

### ● Forced Air Circulation

Forced circulation with a fan inside the closed control cabinet.

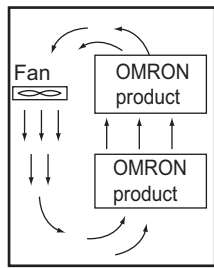

Forced Air Circulation

### ● Room Cooling

Cool the entire room where the control panel is located.

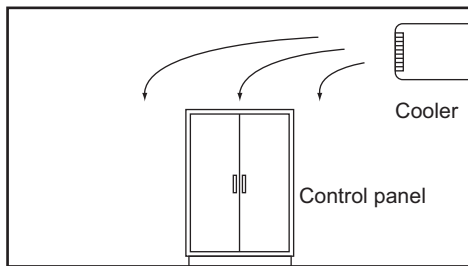

Room Cooling

## Low Temperatures

The Panel PC may not start normally if the temperature is below 0°C when the power is turned ON. Maintain an ambient air temperature of at least 5°C by implementing measures such as installing a low-capacity space heater in the panel.

Alternatively, leave the Panel PC power ON to keep the Panel PC warm.

### 5-3-4 Humidity

Rapid temperature changes can cause condensation to occur, resulting in malfunctioning due to short-circuiting.

When there is a possibility of this occurring, take measures against condensation, such as leaving the Panel PC power ON at night or installing a heater to keep it warmer.

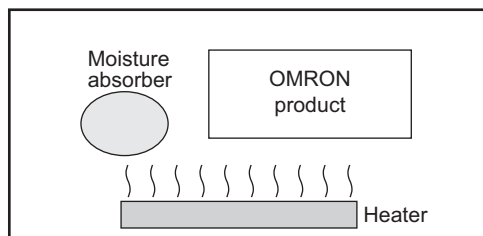

Examples of Measures against Condensation

### 5-3-5 Vibration and Shock

The Panel PC is tested for conformity with the sine wave vibration test method (IEC 60068-2-6) and the shock test method (IEC 60068-2-27) of the Environmental Testing for Electrotechnical Products. It

is designed so that malfunctioning will not occur within the specifications for vibration and shock. If, however, the Panel PC is to be used in a location in which it will be directly subjected to regular vibration or shock, then implement the following countermeasures:

- Separate the Panel PC from the source of the vibration or shock. Or secure the Panel PC with rubber padding to prevent vibration.
- Make the building or the floor vibration-resistant.
- Prevent shocks when other devices, such as electromagnetic contactors, operate. Secure either the source of the shock or the Panel PC with rubber padding.

### 5-3-6 Atmosphere

Using the Panel PC in any of the following locations can cause defective contact with connectors and corrosion of components. Implement countermeasures such as purging the air as required.

- In locations exposed to dust, dirt, salt, metal powder, soot, or organic solvents, use a panel with an airtight structure. Be careful of temperature increases inside the panel.
- In locations exposed to corrosive gas, purge the air inside the panel to clear the gas and then pressurize the inside of the panel to prevent gas from entering from outside.
- In locations where flammable gas is present, either use an explosion-protected construction or do not use the Panel PC.

### 5-3-7 Electrical Environment

When installing or wiring devices, make sure that there will be no danger to people and that noise will not interfere with electrical signals.

## Installation Location

Install the Panel PC as far away as possible from high-voltage (600 V or higher) and power devices to ensure safe operation and maintenance.

Example of Recommended Equipment Arrangement

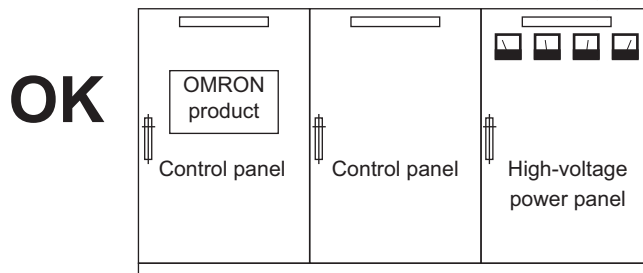

Example of Poor Equipment Arrangement

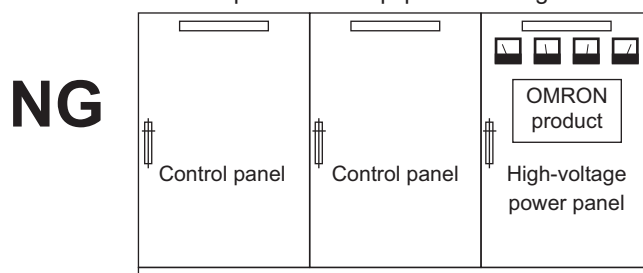

Examples of Equipment Arrangement in Panel with High-voltage Devices

## Hardware Arrangement

The coils and contacts in electromagnetic contacts and relays in an external circuit are sources of noise. Do not install them close to the Panel PC. Locate them at least 100 mm away from the Panel PC.

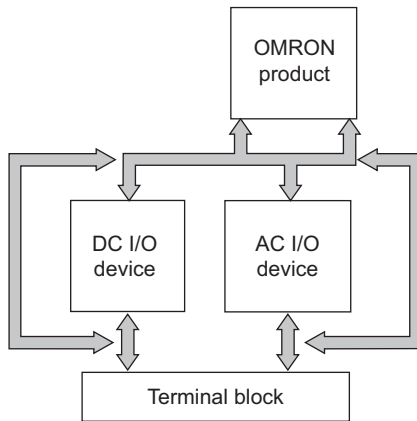

Example of Arrangement in Panel

## Wire Layout for the Power Supply

Observe the following points when wiring the power supply system.

- Separate the Panel PC power supply from the I/O device power supply and install a noise filter near the Panel PC power supply feed section.
- Use an isolating transformer to significantly reduce noise between the Panel PC and the ground. Install the isolating transformer between the Panel PC power supply and the noise filter, and do not ground the secondary coil of the transformer.
- Keep the wiring between the transformer and the Panel PC as short as possible, twist the wires well, and keep the wiring separate from high-voltage and power lines.

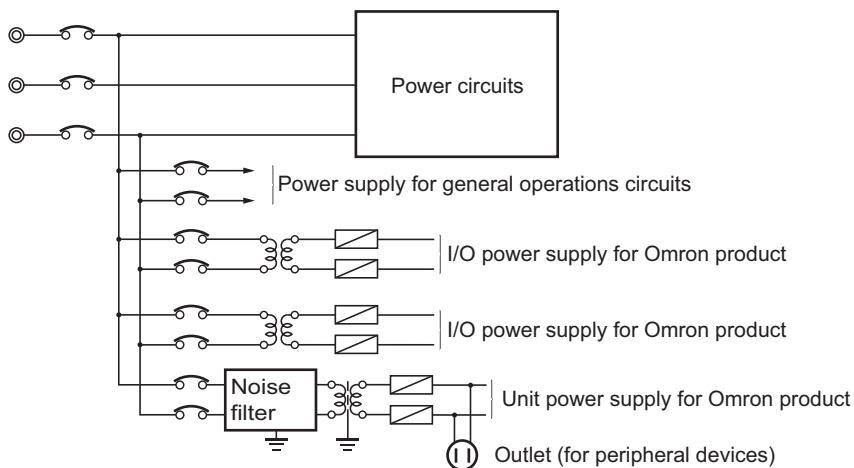

Power Supply System Diagram

## Wire External I/O Signal Lines

Observe the following points when wiring the external I/O signal lines.

- To absorb reverse electromotive force when an inductive load is connected to an output signal, connect a surge suppressor near the inductive load in an AC circuit, or connect a diode near the inductive load in a DC circuit.

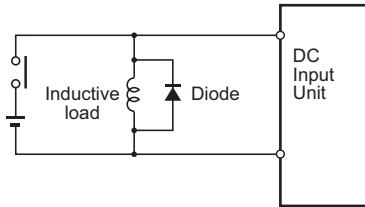

Connect a diode in a DC circuit.

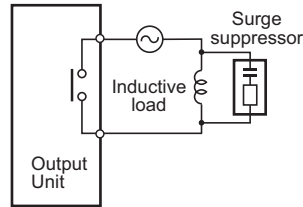

Connect a surge suppressor in an AC circuit.

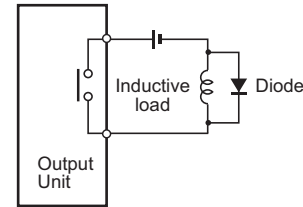

Connect a diode in a DC circuit.

Input Signal Noise Countermeasures

Output Signal Noise Countermeasures

- Never bundle output signal lines with high-voltage or power lines, and do not route them in close proximity or parallel to such lines. If output signal lines must be routed in close proximity to such lines, place them in separate ducts or conduits. Be sure to ground the ducts or conduits.

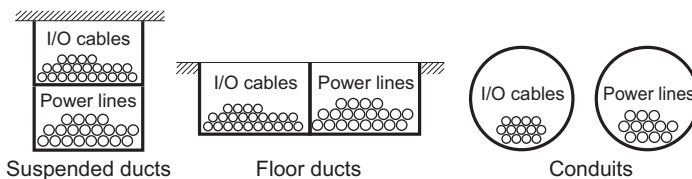

I/O Cable Arrangement

- If the signal lines and power lines cannot be routed in separate ducts, use shielded cable. Connect the shield to the ground terminal at the Panel PC, and leave it unconnected at the input device.
- Wire the lines so that common impedance does not occur. Such wiring will increase the number of wires, so use common return circuits. Use thick wires with sufficient allowance for the return circuits, and bundle them with lines of the same signal level.
- For long I/O lines, wire the input and output signal lines separately.
- Use twisted-pair wires for pilot lamps (and particularly lamps with filaments).
- Use countermeasures, such as CR surge absorbers and diodes, for input device and output load device noise sources, as required.

## External Wiring

Wiring, and noise countermeasures in particular, are based on experience, and it is necessary to closely manage wiring based on experience and information in the manuals.

### ● Wiring Routes

Each of the following combinations includes different signal types, properties, or levels. They will cause the signal-to-noise ratio to drop due to factors such as electrical induction. As a general rule when wiring, either use separate cables or separate wiring routes for these items. Future maintenance operations and changes to the system will also be made easier by carefully organizing the wiring from the start.

- Power lines and signal lines
- Input signals and output signals
- Analog signals and digital signals
- High-level signals and low-level signals
- Communications lines and power lines
- DC signals and AC signals
- High-frequency devices (such as Inverters) and signal lines (communications)

### ● (Routing of) Wiring

Observe the following points when wiring power supply and signal cables.

- When routing signal cables with differing characteristics through the same duct, always keep them separated.
- As much as possible, avoid routing multiple power supply lines through the same duct. If it cannot be avoided, then construct a partition between them in the duct and ground the partition.

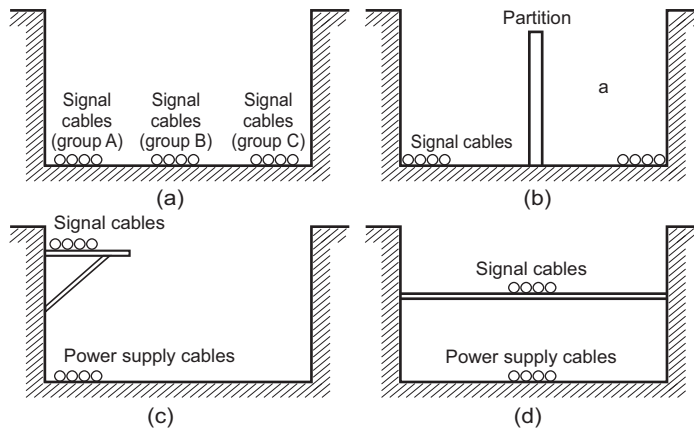

Partitioning Methods for Signal and Power Supply Cables

- To avoid overheating the conduits when using conduits for wiring, do not place wires for a single circuit in separate conduits.

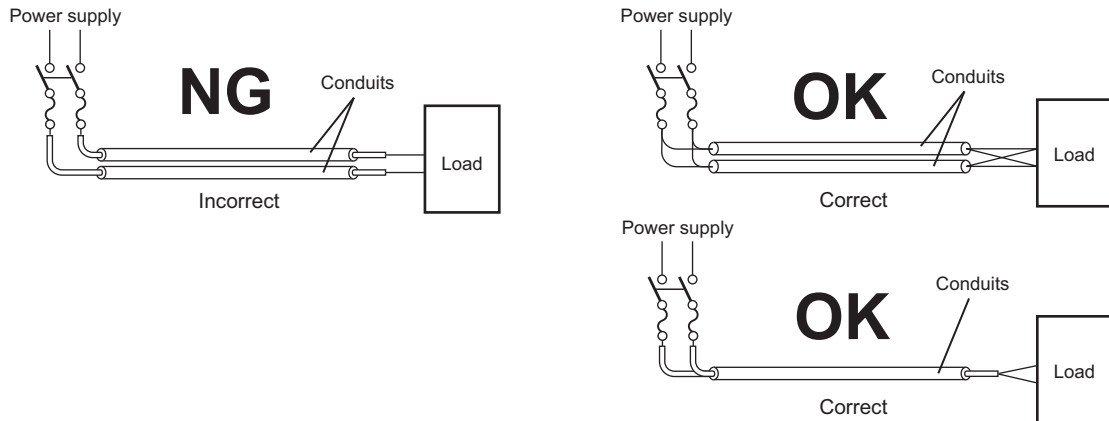

Parallel Wiring (Single Phase)

- Power cables and signal cables adversely affect each other. Do not wire them in parallel.
- Noise induction may occur if the Panel PC is installed in a panel that includes high-voltage devices. Wire and install them as far apart as possible.
- Either install the Panel PC a minimum of 200 mm away from high-voltage lines or power lines, or place the high-voltage lines or power lines in metal tubing and completely ground the metal tubing to 100  $\Omega$  or less.

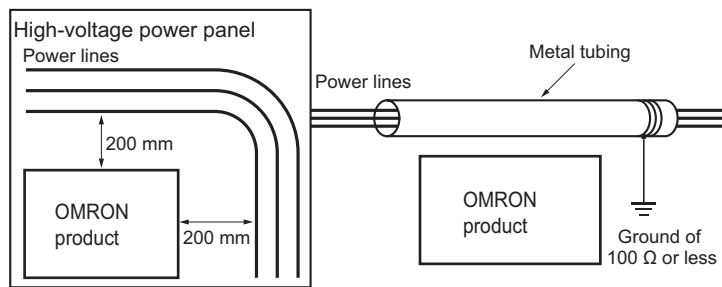

Example: Separating an OMRON product from Power Lines

## ● Wiring Ducts

Whenever possible, route the cables and wires through wiring ducts.

Install the wiring ducts so that it is easy to route the wires from the Panel PC directly into the duct.



### Additional Information

Refer to *Distance for Cooling* on page 5-16 for the minimum required distances.

It is convenient to use wiring ducts that have the same depth as the Panel PC.



- **Other Precautions**

Basic I/O Units have both plus and minus commons, so pay attention to the polarity when wiring.

## 5-3-8 Panel Mount Procedure

Ensure the panel cut out is ready before beginning the mounting procedure.  
Refer to *Prepare the Mounting Surface* on page 5-26 for details.

Tools required: Torque screw driver with hexagon 2 mm bit.

The Industrial Panel PC is equipped with 8 (12.1", 15.4") or 9 (18.5") retractable mounting brackets on the back of the Panel PC.

These brackets are used to fasten and secure the Panel PC to the mounting surface.

Use the following procedure to mount the Panel PC to the mounting surface:

- 1 Ensure all retractable mounting brackets (A) are in the retracted position ①. If required press the mounting brackets in the retracted position and hand tighten the allen bolt ②.

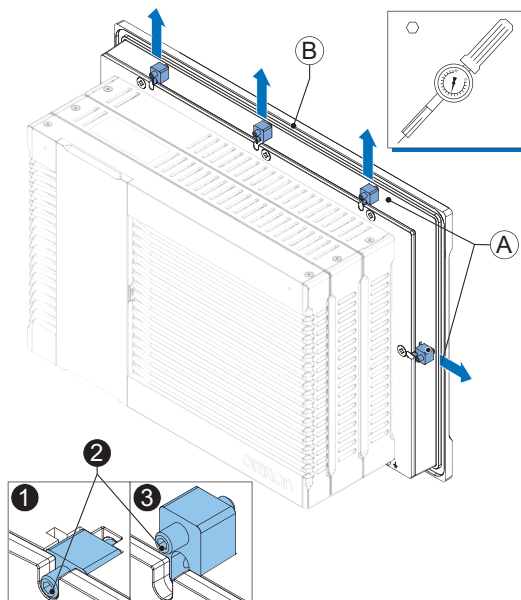

- 2 Insert the Panel PC into the mounting surface cut out so the bezel (B) touches the mounting surface.
- 3 Loosen the allen bolts ② of the mounting brackets.  
The mounting brackets are spring loaded and will extend ③ when loose.
- 4 Ensure all mounting brackets extend to overlap the mounting surface.
- 5 Tighten all mounting brackets to a torque of 0.6 N·m to maintain water and dust resistance.



### Precautions for Safe Use

The mounting panel must be between 1.6 and 6.0 mm thick. Tighten the Mounting Brackets evenly to a torque of 0.6 N·m to maintain water and dust resistance. If the tightening torque exceeds the specified value, or the tightening is not even, deformation of the front panel may occur. Additionally, make sure the panel is not dirty or warped and that it is strong enough to hold the product.

## Prepare the Mounting Surface

The Industrial Panel PC can be mounted in a landscape or portrait orientation. The mounting hardware is integrated into the back of the Panel PC.

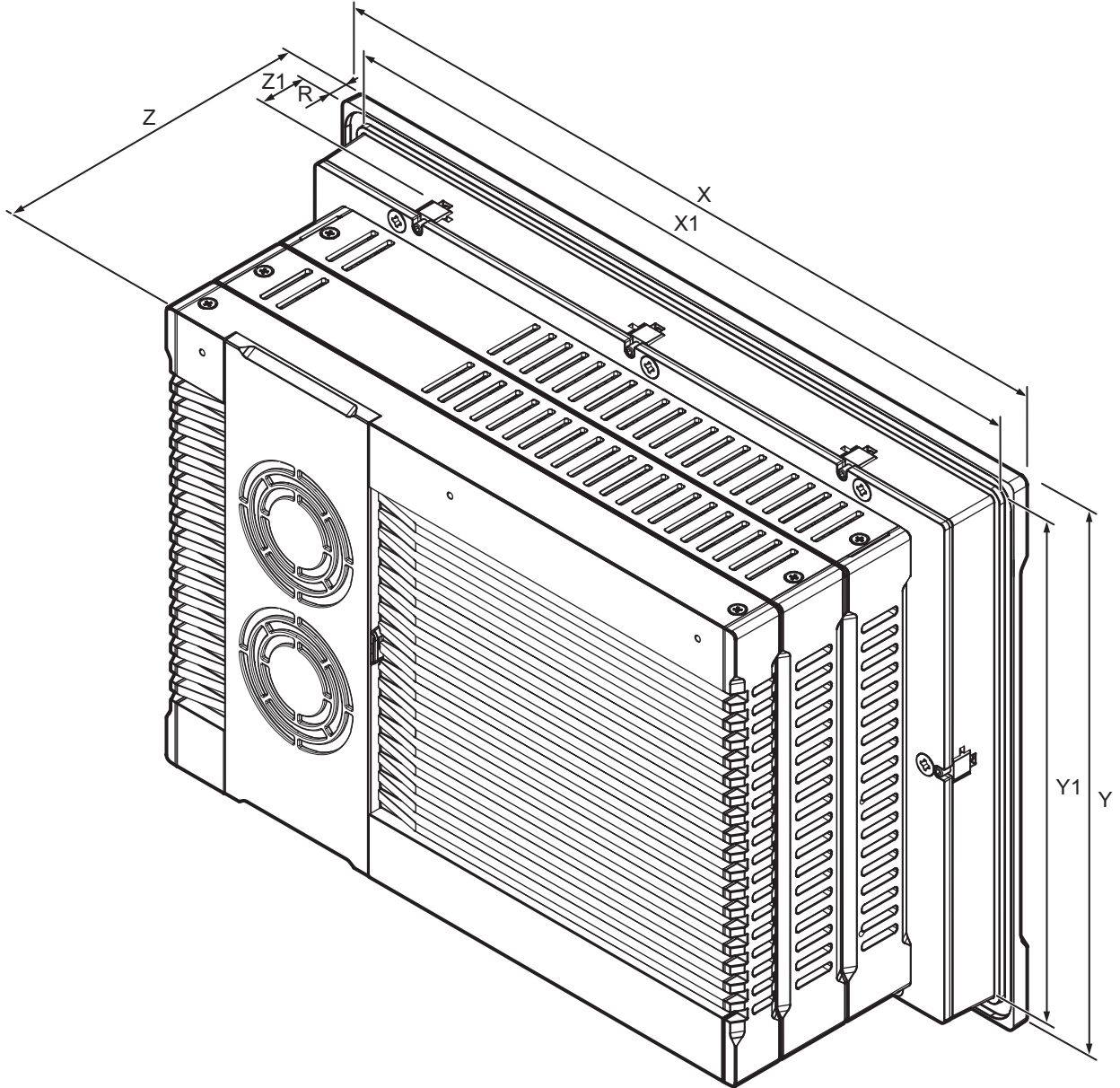

Item	Model Specifications		
	12.1 inch <sup>*1</sup>	15.4 inch <sup>*1</sup>	18.5 inch <sup>*1</sup>
Panel cutout dimensions	Width X1 = 314 <sup>-0 +1</sup> mm Height Y1 = 216 <sup>-0 +1</sup> mm	Width X1 = 383 <sup>-0 +1</sup> mm Height Y1 = 259 <sup>-0 +1</sup> mm	Width X1 = 463 <sup>-0 +1</sup> mm Height Y1 = 285 <sup>-0 +1</sup> mm
Panel thickness range <sup>*2</sup>	Panel thickness range Z1 = 1.6 to 6.0 mm		
Dimensions	Refer to 4-1-1 <i>Dimensions and Weight</i> on page 4-2 for X, Y, Z and R dimensions.		

\*1. Refer to 1-4 *Product Configuration Panel PC* on page 1-5 for model details.

\*2. The minimum panel thickness depends on the panel material. For the most common materials the minimum panel thickness is mentioned in the following steps.

- 1** Ensure the mounting surface conforms to following requirements.

Standards conformance	Material	Mounting panel requirements
IP65	Steel	Thickness 1.6 to 6.0 mm
	Aluminum	Thickness 2.5 to 6.0 mm

- 2** Create an opening in the mounting surface.

The table before step 1 gives an overview of the cut out dimensions for the Panel PC. Prepare a rectangular cut out with the dimensions X1 and Y1.

- 3** Ensure the mounting surface is clean and not warped.

## 5-3-9 VESA Mount Procedure

Use the following procedure to mount your Panel PC using the VESA Mount bracket.



### Precautions for Safe Use

- Always use an arm construction with sufficient strength to support the Panel PC and the additional forces from making adjustments. Not doing so may lead to system damage or injury.
- Carefully follow the instructions in the manual when mounting or dismantling a unit from the VESA mount bracket, to avoid system damage or injury.
- Check the reliability of the mechanical construction of arm and VESA mount bracket on a regular basis. Doing so will prevent unexpected breakdown of the construction, which might lead to system damage or injury.



### Additional Information

- Refer to 5-4-2 *Ground* on page 5-31 for grounding details.
- Refer to 3-10-1 *VESA Mount Brackets* on page 3-27 for the bracket model.

To mount the Panel PC with a VESA bracket:

- 1** Unpack the product.  
Remove the fasteners from the VESA bracket.  
Discard the plastic spacer bus, this component is not needed for the VESA mounting.
- 2** Position the VESA bracket and the optional VESA handle at the desired location with the 4 M4x16 hexagon socket head screws and washers supplied with the VESA bracket.  
Position the optional VESA handle between the VESA bracket and the external mounting when applicable. The VESA handle is intended for landscape use.  
Use the 4 holes

  - at location **(A)** for 18.5 inch models
  - at location **(B)** for 15.4 inch models
  - at location **(C)** for 12.1 inch models

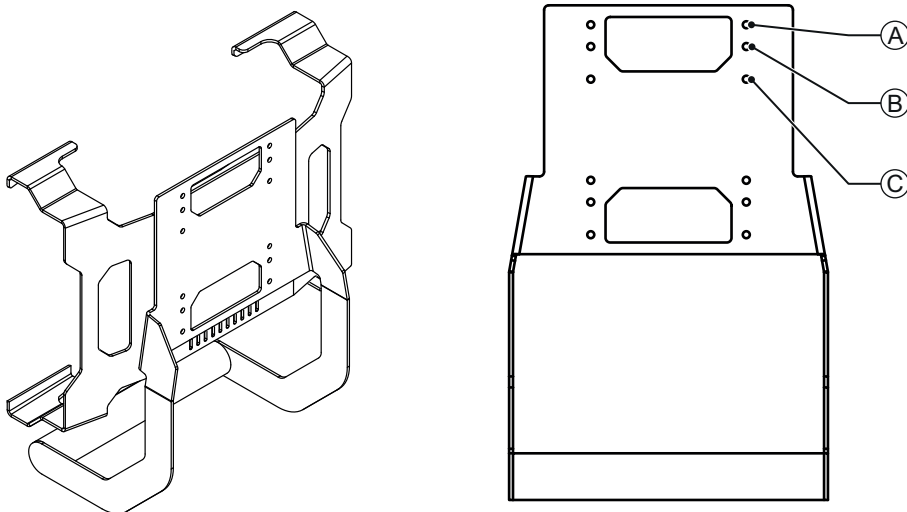

- 3** Tighten the 4 screws with a torque between 2.5 and 3.0 N m with a hexagon tool.

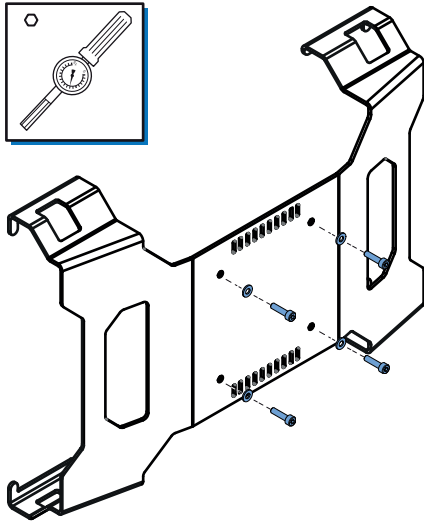

The bracket shape can differ depending on the bracket ID.

- 4** Mount the ground connection.  
Refer to *Ground Connection Details* on page 5-37 for details.  
The VESA bracket does not require separate grounding.

- 5** Loosen the allen bolts ② of 4 mounting brackets.  
Loosen the bolts of the two mounting brackets on top and bottom that are closest to the corners. The mounting brackets are spring loaded and will extend ③ when loose.

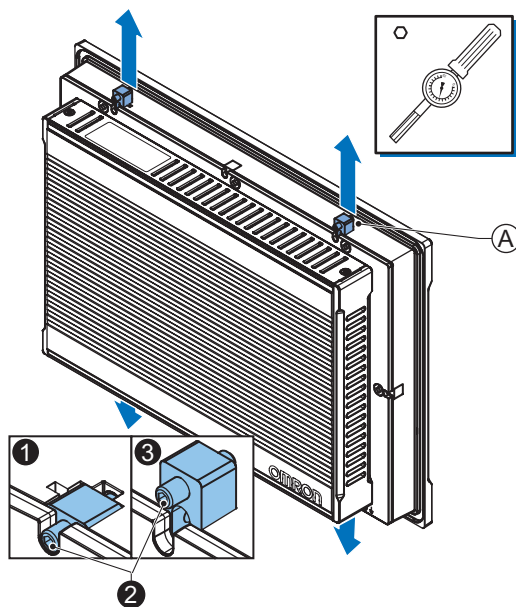

- 6** Insert the Panel PC into the VESA bracket.  
Position the Panel PC to rest in both bottom arms of the VESA bracket with both extended mounting brackets inside the VESA bracket.  
Rotate the top of the Panel PC towards the top arms of the VESA bracket. Push down both mounting brackets to get them inside the VESA bracket, they will extend automatically when the Panel PC is correctly positioned.

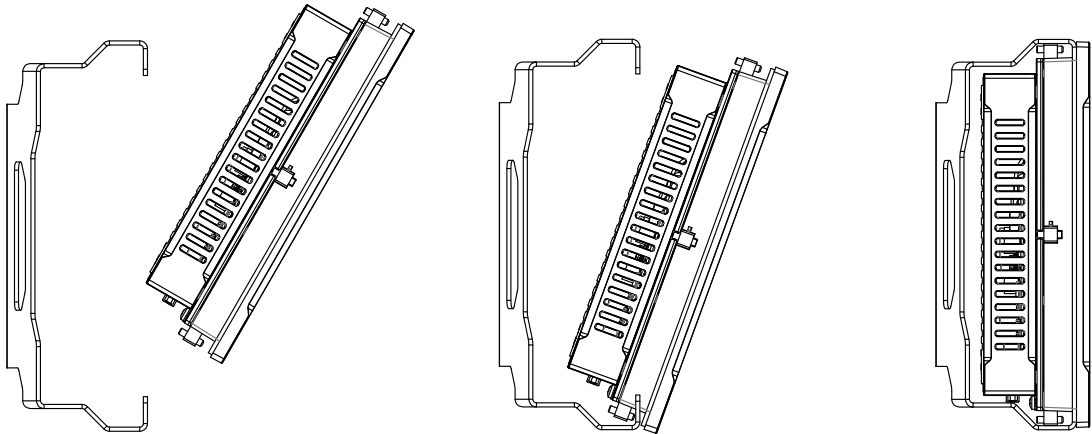

The bracket and the Panel PC can differ depending on the product configuration.

- 7** Tighten all four mounting brackets with a torque of 0.6 N·m and ensure the frontside of each allen bolt overlaps the surface at the inside of the VESA bracket.
- 8** Connect the connectors and wiring.

Fix the cables (B) against the bracket (C) using cable ties (A) and the 10 fixation slots on the bottom of the bracket.

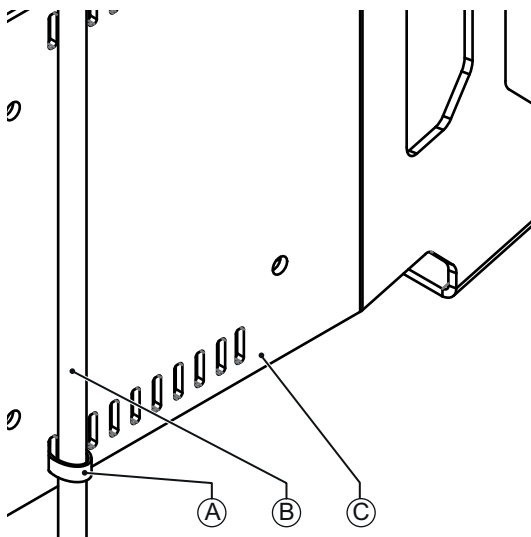

The Panel PC is mounted.

## 5-4 Wire

This section describes how to wire the Industrial Panel PC.

### 5-4-1 Wiring Warnings and Cautions

This section describes the Warnings and Cautions when wiring the Industrial Panel PC.

#### WARNING

Provide safety measures in external circuits to ensure safety in the system if an abnormality occurs due to malfunction of the product or due to other external factors affecting operation. Not doing so may result in serious accidents due to incorrect operation.



#### WARNING

Emergency stop circuits, interlock circuit, limit circuits, and similar safety measures must be provided in external control circuits.



#### WARNING

Unintended behavior may occur when an error occurs in internal memory of the product. As a countermeasure for such problems, external safety measures must be provided to ensure safe operation of the system.



#### Precautions for Safe Use

Do not let metal particles enter the product when preparing the panel. Do not allow wire clippings, shavings, or other foreign material to enter any product. Otherwise, the product burning, failure, or malfunction may occur. Cover the product or take other suitable countermeasures, especially during wiring work.

### 5-4-2 Ground

This section describes how to ground the Industrial Panel PC.

#### WARNING

Always connect to a ground of 100  $\Omega$  or less when installing the product.



## ⚠ CAUTION

The product has an internal non-isolated DC power supply. Circuit ground (0 VDC) and frame ground are connected together. When connecting a non-isolated device or a non-isolated interface to the product, take appropriate actions to avoid communication failures or damage to the mentioned ports.

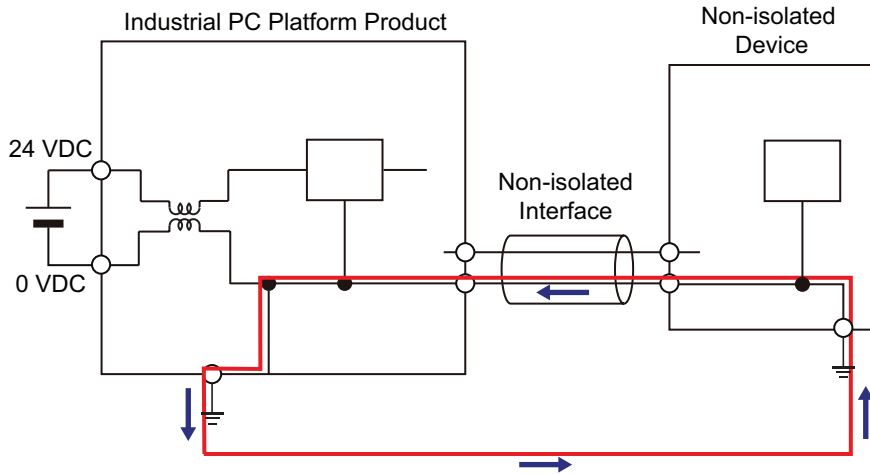

## ⚠ CAUTION

Never ground the 24 VDC side of the power supply. This may cause a short circuit.



The shielding of the communication connectors are directly bonded to the case and to the ground of the Panel PC.

The shield of a communication cable should be terminated to ground at both ends of the cable with a low impedance connection. A large surface area surrounding the entire cable shield ensures a low impedance connection, avoid the use of pigtailed.

Potential differences between the two connected communicating devices might cause an equipotential current to flow through the shielding connected at both ends.

To avoid equipotential currents on the cable shields, an additional equipotential bonding conductor must be installed.

Refer to IEC 61918 for guidelines regarding conductor sizing and length to prevent a voltage offset between two communicating devices exceeding 1 V.

Make sure to run the bonding conductor in close proximity to the communication cable.

The Panel PC has a protection ground connection because the metal part of the Panel PC outside of the enclosure must be part of the protection grounding of that enclosure (for example a cabinet).

There are no power supply voltages used in the Panel PC which require protection grounding.

## Considerations for Earthing Methods

Local potential fluctuations due to lightning or noise occurred by power devices will cause potential fluctuations between ground terminals of devices. This potential fluctuation may result in device malfunction or damage. To prevent this, it is necessary to suppress the occurrence of a difference in electrical potential between ground terminals of devices. You need to consider the earthing methods to achieve this objective.

The recommended earthing methods for each usage condition are given in the following table.

Specification of communications cables	Earthing methods		
	Equipotential bonding system	Star earthing	Daisy chain
The cable shield connected to the connector hood at both ends of the communications cable	Recommended	Not recommended	Not recommended



### Additional Information

- In a country or region where the earthing method is regulated, you must comply with the regulations. Refer to the applicable local and national ordinances of the place where you install the system, or other international laws and regulations.
- Ethernet switches are used with the EtherNet/IP. For information on the environmental resistance of the Ethernet switch to use, the grounding between Ethernet switches, or the specifications of cables, ask the Ethernet switch manufacturer.

Each of these earthing methods is given below.

## Equipotential Bonding System

Equipotential bonding is an earthing method in which steel frames and building structures, metal ducts and pipes, and metal structures in floors are connected together and make connections to the earth trunk line to achieve a uniform potential everywhere across the entire building. We recommend this earthing method.

The following figure shows an example of an equipotential bonding system.

Connect the main earthing terminal and building structures together with equipotential bonding conductors and embed the mesh ground line in each floor.

Connect the ground line of each control panel to the equipotential bonding system.

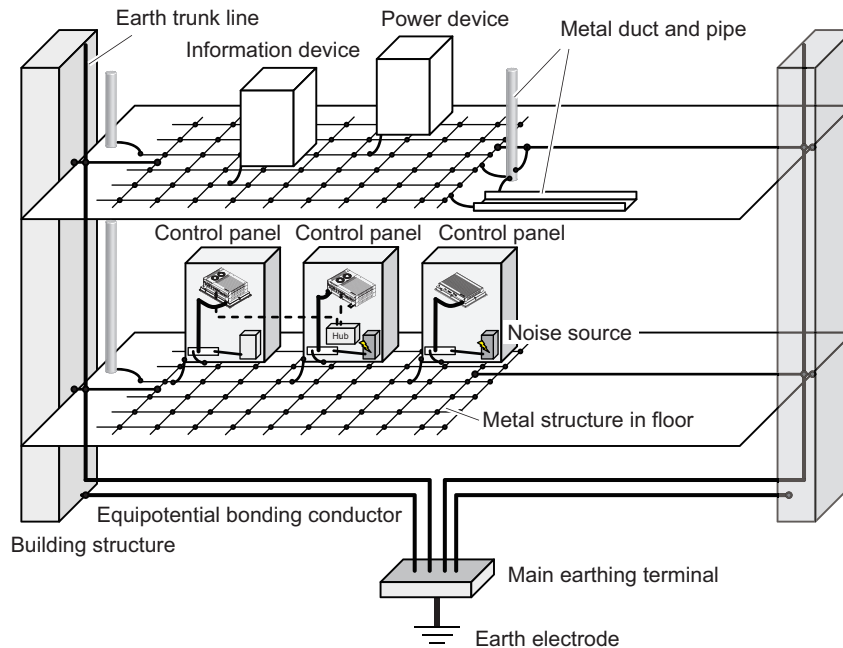

## Star Earthing

If the earthing method used for the building is not equipotential bonding or the earthing system is unknown, choose (a) from among the earthing methods given below.

### a. Connecting devices and noise sources to separate earth electrodes

This is an earthing method to separately ground an earth electrode of the device that is connected with a communications cable or other devices and an earth electrode of a high-power device that could be a noise source, such as a motor or inverter.

Each earth electrode must be ground to  $100\ \Omega$  or less.

Connect the ground lines of the device that is connected with a communications cable and other devices as a bundle to a single earth electrode. Be sure that the earth electrode is separated by a minimum of 10 m from any other earth electrode of a device that could be a noise source.

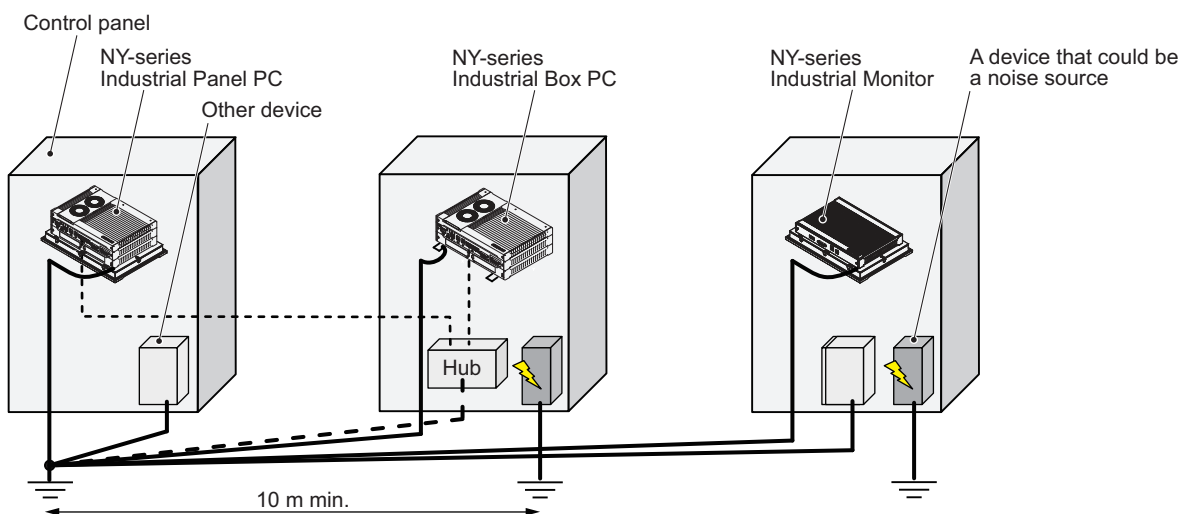

### b. Connecting devices and noise sources to a common earth electrode

This is an earthing method to connect the device that is connected with a communications cable, other devices, and a device that could be a noise source, to a common earth electrode.

This earthing method is not recommended because the device that could be a noise source may interfere electromagnetically with other devices.

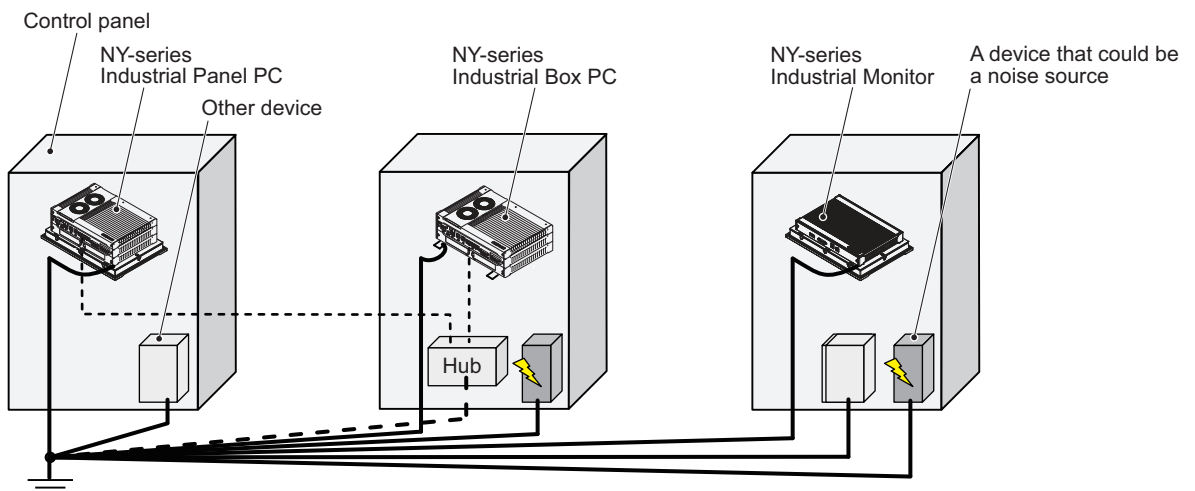

## Daisy-chain

This is an earthing method to connect the device that is connected with a communications cable, other devices, and a device that could be a noise source using a Daisy-chain topology to a common earth electrode.

This earthing method is not recommended because the device that could be a noise source may interfere electromagnetically with other devices.

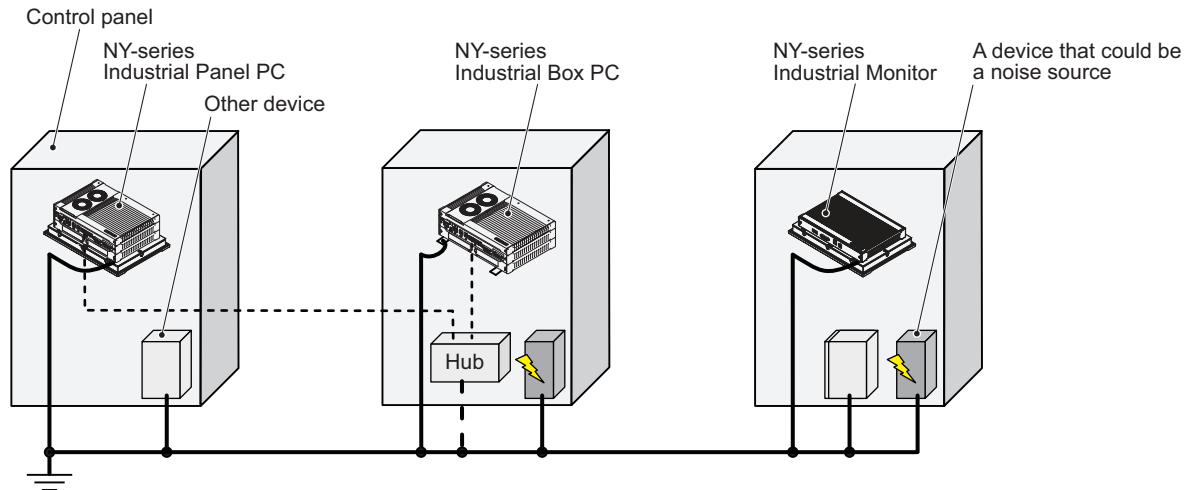

## Ground Connection Details

This section provides details about the ground connection.

Use the ground terminal to ground your Panel PC.

The washers and screw (A) are pre-mounted at the Panel PC.

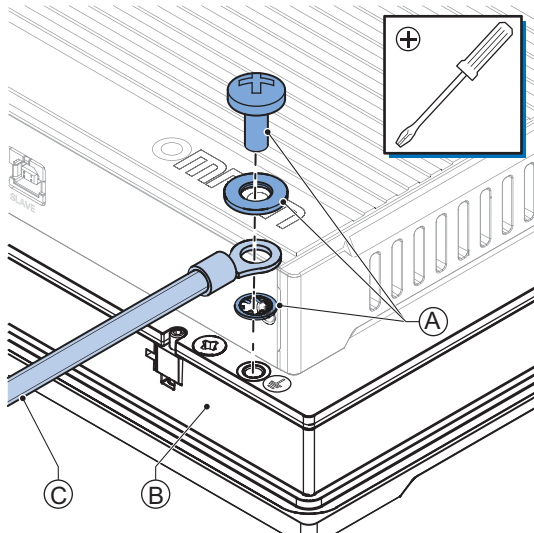

### Grounding the Panel PC

Remove the pre-mounted washers and screw (A) and then mount the ground connection wire (C) to the Panel PC (B) using the washers and screw (A).

Tighten the screw with a torque of 1.2 N·m max.

### ● Crimp terminals

Use crimp terminals with dimensions X = M4 and Y = 8 mm max.



### 5-4-3 Wire the Power Connector

This section describes how to wire the power connector.



#### Precautions for Safe Use

---

- Do not perform a dielectric strength test.
  - Always use the recommended uninterruptible power supply (UPS) to prevent data loss and other system file integrity issues caused by unexpected power interruption. Back up the system files in the planned way to prevent data loss and other system file integrity issues caused by incorrect operation.
- 



#### Additional Information

---

- The selected conductor size must match with the used maximum power supply capacity or an overcurrent protection device must be used.
  - The used wires and the overcurrent protection device must meet the applicable national standards.  
Standards are:
    - NEC (National Electric Code)
    - CEC (Canadian Electrical Code)
    - international applicable standards
  - Refer to 4-1-2 *General Electrical Specifications* on page 4-6 for electrical specifications.
  - Refer to 4-1-3 *Power Consumption Specifications* on page 4-7 for power consumption specifications.
  - Refer to 3-10-10 *UPS* on page 3-36 for UPS information.
-

## Power Connector Wiring Materials

Use the power supply connector that was supplied to connect the power supply to the Industrial Panel PC.

- Select power supply conductors with consideration to the voltage drop and heat generation for the cable length at the installation environment.
- Always use twisted wires to minimize the occurrence of electrical disturbance.
- Recommended power supply conductor sizes are provided in the table.

Wire type	Conductor cross-section
Solid conductor	0.5 to 10 mm <sup>2</sup>
Flexible conductor	0.5 to 6 mm <sup>2</sup>
Flexible conductor, with ferrule and no plastic sleeve	0.5 to 6 mm <sup>2</sup>
Flexible conductor, with ferrule and plastic sleeve	0.5 to 4 mm <sup>2</sup>
Minimum AWG according to UL/cUL	20
Maximum AWG according to UL/cUL	8

- Power Supply Connector

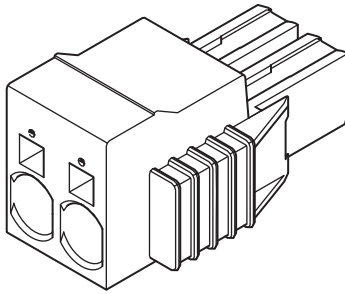

## DC Power Supply

The OMRON S8VK-series power supply is recommended for use with the Industrial Panel PC.



### Additional Information

- Refer to *3-10-9 Power Supply* on page 3-35 for more information.
- Refer to *4-1-3 Power Consumption Specifications* on page 4-7 for power consumption details.

## Power Connector Wiring Procedure

Use the following procedure to wire the power connector.

- 1 Ensure the power connector is not connected to the Panel PC.

- 2 Remove the sheath from the power supply wires.



### Precautions for Safe Use

Observe the following precautions to prevent broken wires.

- When you remove the sheath, be careful not to damage the conductor.
- Connect the conductor without twisting the wires.
- Do not weld the conductors. Doing so may cause the wires to break with vibration.

- 3 Insert a 2.5 mm flat-blade screwdriver in the small opening above the cable opening ① to unlock the cable entry and then push the wire all the way to the back of the cable opening ②.

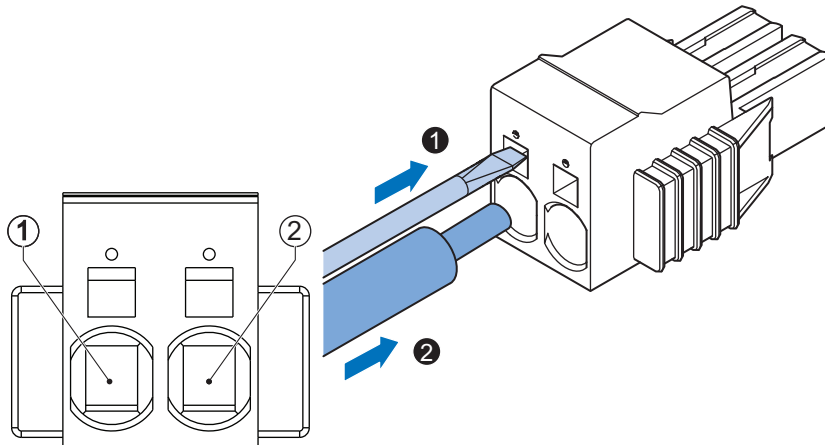

Pin	Description
1	24 VDC
2	0 VDC

- 4 Remove the screwdriver.

Do not apply stress to the cable after you have connected the wires.

## 5-4-4 Wire the I/O Connector

This section describes how to wire the I/O connector.

### I/O Connector Wiring Materials

Use the supplied I/O connector to connect the inputs and outputs to the Industrial Panel PC. Recommended I/O conductor sizes for the connector are provided in the table.

Wire type	Conductor cross-section
Solid conductor	0.2 to 1.5 mm <sup>2</sup>
Flexible conductor	
Flexible conductor, with ferrule and no plastic sleeve	0.25 to 1.5 mm <sup>2</sup>
Flexible conductor, with ferrule and plastic sleeve	0.25 to 0.75 mm <sup>2</sup>
Minimum AWG according to UL/cUL	24
Maximum AWG according to UL/cUL	16

### I/O Connections

This section describes I/O connection details.

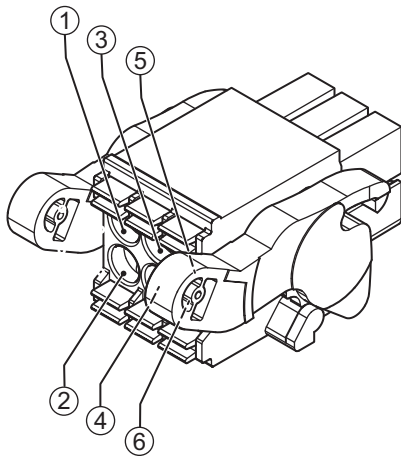

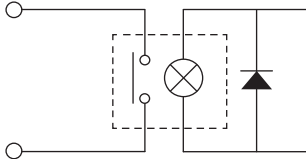
Pin	Description	Internal Circuit Details
1	Output 1	Output 1 has an internal relay. Wire this according to the input device connected to this output. 
2		

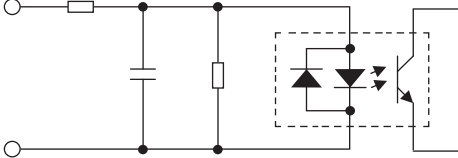
Pin	Description	Internal Circuit Details
3	Input 1	<p>Input 1 and Input 2 are bi-directional and isolated. Each input can be wired as sinking (NPN) or sourcing (PNP). Wire these according to the output device connected to the inputs.</p> 
4		
5	Input 2	
6		



### Additional Information

Refer to:

- *4-2-2 I/O Connector Specifications* on page 4-27 for I/O connector specifications.
- *I/O Connector Output Details* on page 4-30 for power status output details.
- *3-10-10 UPS* on page 3-36 for UPS information.

## I/O Connector Wiring Procedure

Use the following procedure to wire the I/O connector.

- 1 Ensure the I/O connector is not connected to the Panel PC.

- 2 Remove the sheath from the wires.



### Precautions for Safe Use

Observe the following precautions to prevent broken wires.

- When you remove the sheath, be careful not to damage the conductor.
- Connect the conductor without twisting the wires.
- Do not weld the conductors. Doing so may cause the wires to break with vibration.

- 3 Remove the I/O connector from the Panel PC.
- 4 Insert a screwdriver in the small groove above the cable entry **1** to unlock the cable entry and then push the wire all the way to the back of the cable opening **2**.

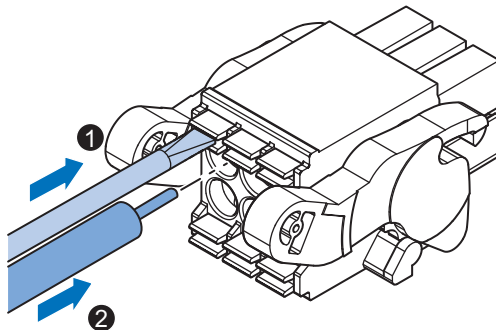

- 5 Remove the screwdriver.

Do not apply stress to the cable after you have connected the wires.

## 5-5 Connect

This section describes how to connect the Industrial Panel PC.

### 5-5-1 Connector Identification

An overview of the connectors of the base layer.

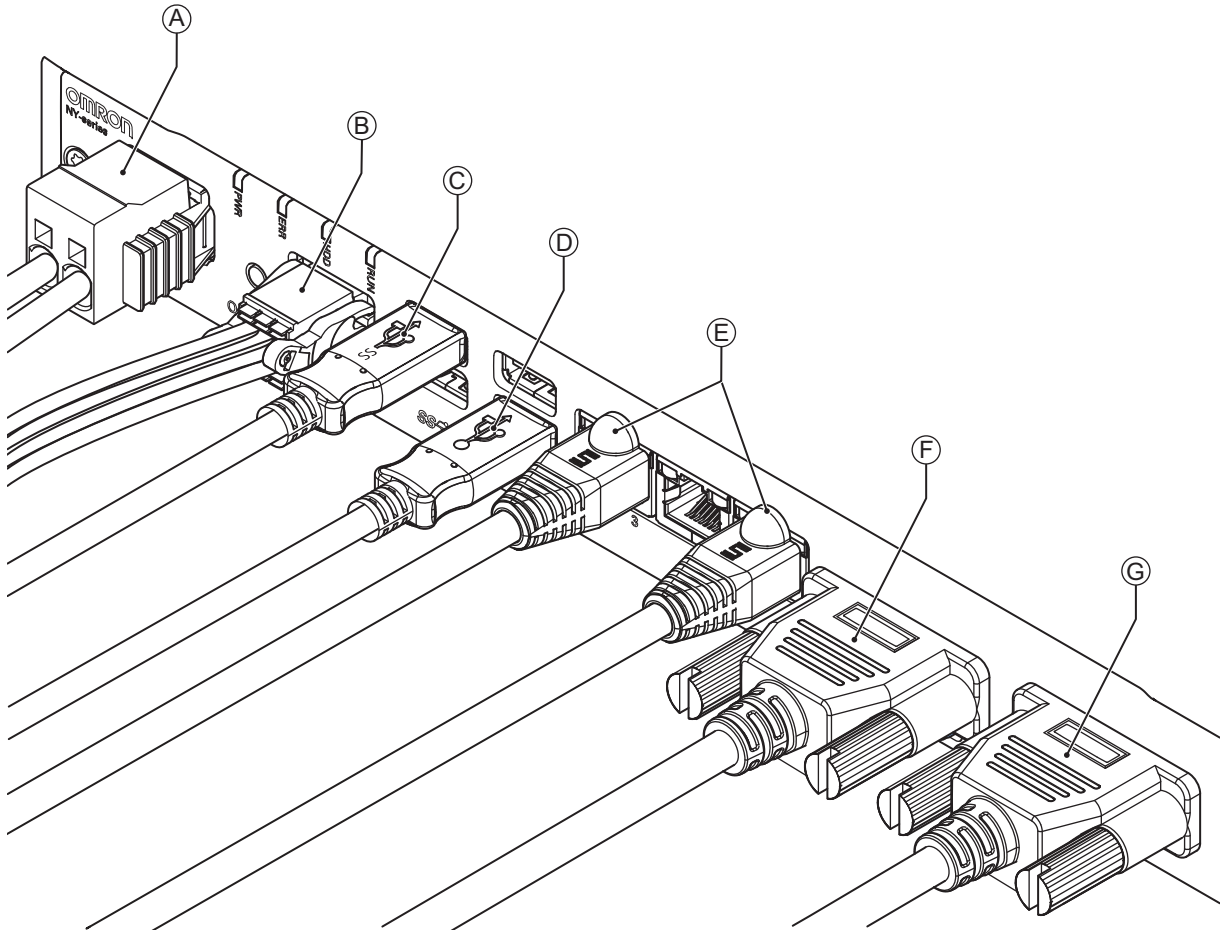

Item	Name	Description
A	Power connector	Lockable power connector
B	I/O connector	2 inputs (UPS signal and power OFF control) and 1 output (power state)
C	USB connectors	2 USB connectors
D	USB connector	2 USB connectors
E	10BASE-T/100BASE-TX/ 1000BASE-T Ethernet connectors	3 RJ45 Gb Ethernet connectors
F	Video connector	Video connector: <ul style="list-style-type: none"> <li>• DisplayPort connector (default)</li> <li>• Digital Visual Interface connector</li> </ul>

Item	Name	Description
G	Option port	Interface connection options for peripheral devices or an additional monitor: <ul style="list-style-type: none"><li>• DisplayPort connector</li><li>• RS-232C connector</li><li>• DVI-D connector</li><li>• NY Monitor Link connector</li><li>• RJ45 Gb Ethernet connector</li></ul>

## 5-5-2 Connection Procedure

Use the following procedure to connect the Industrial Panel PC.

Ensure the Panel PC is securely fastened to the mounting surface.

Ensure the mounted Panel PC can be connected to power and peripheral devices. Remove dust covers where applicable and store them in a safe place.



### Additional Information

- Refer to 5-3 *Mount* on page 5-14 for mounting details.
- Refer to 3-10 *Optional Hardware* on page 3-27 for the cables advised by Omron.  
Refer to individual cable specifications for cable bending requirements and connector clearance.

Use the following procedure to connect the Panel PC:

- 1** Ensure the ground terminal is connected.  
Refer to 5-4-2 *Ground* on page 5-31 for grounding details.
- 2** Connect the power connector (A).  
Hold the black part to enable the auto-locking mechanism.

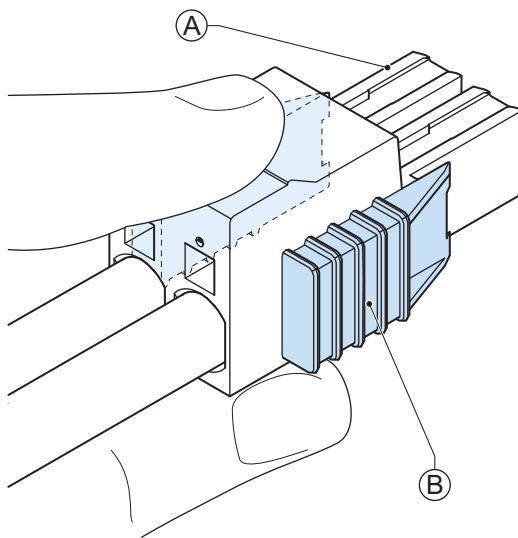

Do not push the orange sliders (B) in the direction of the Panel PC because this will unlock the connector.

**3** Connect the I/O connector.

Hold the black part **(A)** when inserting the connector, this enables the auto-locking mechanism.

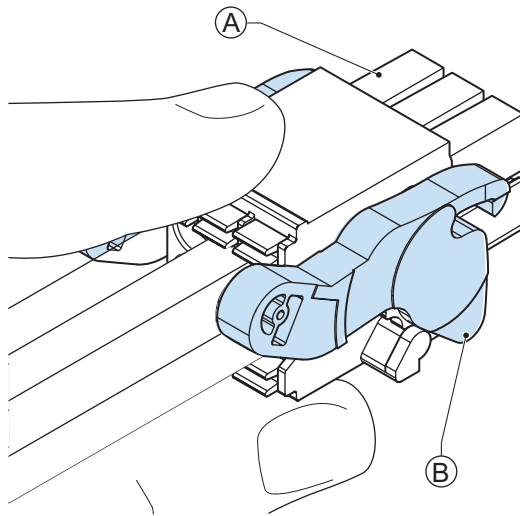

Do not tilt the orange levers **(B)** because this will unlock the connector.

- 4** Connect an external monitor such as the Industrial Monitor to the video connector. Optional tighten the fastening screws or use the optional NYML connector. For an Industrial Panel PC and for several other IPC configurations this is optional.
- 5** Connect all remaining connectors and tighten the fastening screws when applicable.
- 6** Connect the USB ports to peripheral devices .
- 7** Connect the Panel PC to the Ethernet interface connector(s).

The Panel PC is connected.

## 5-6 Initial Power ON

This section describes how to Power ON the Industrial Panel PC for the first time.

### WARNING

Ensure that installation and post-installation checks of the product are performed by personnel in charge who possess a thorough understanding of the machinery to be installed.



### 5-6-1 Initial Power ON Procedure

Use the following procedure to power ON the Industrial Panel PC for the first time.

- 1** Ensure the following conditions are present before applying power for the first time:
  - The Panel PC is securely fastened to the mounting surface.
  - The Panel PC is connected to ground.
  - All connectors are securely fastened.
- 2** Ensure that an optional connected monitor(s) is powered ON.
- 3** Connect an optional keyboard and/or mouse.



#### Additional Information

- If using an OMRON Industrial Panel PC, this may not be required because it has touch functionality.
- Do not connect additional storage devices before the installation of the operating system completed. Adding storage devices like a USB flash drive, an SD memory card or a PCIe card might influence the default drive letter sequence.

- 4** Ensure the power supply is ON.



#### Precautions for Safe Use

Always check the power supply and power connections before applying power. Incorrect power connections can damage the product or cause burning.

- 5** Press the power button and release within 1 second.  
The Panel PC starts and the PWR LED will go ON.



#### Additional Information

- Do not connect or disconnect the DVI-D cable while power is supplied to the Panel PC.
- If a Windows operating system is preinstalled:
  - the Windows configuration will automatically start
  - refer to 5-6-2 *Windows Startup First Time* on page 5-50 for details

- 6** Verify the ERR LED is OFF.

The Panel PC is ON and if an operating system is installed it will start.



### Precautions for Safe Use

---

Always use the SMART monitoring feature for storage devices that do not comply to the Omron Storage Device Specifications. Monitor the operating temperature and vibrations to ensure they stay within the environmental specifications of the storage device.

---



### Additional Information

---

- The first time initialization will prepare the system and automatically reboot the Panel PC when required.
  - Install support software to fully utilize your Panel PC and optional connected hardware.
- 



### Additional Information

---

If a drive with a windows operating system is installed a system backup of the factory state can be created. To create this system backup download and use the Rescue Disk Creator. Refer to [the OMRON website](#) for download details.

---

## 5-6-2 Windows Startup First Time

Use the following procedure for the first time startup of Windows on your Panel PC.



### Additional Information

Do not power OFF the Panel PC during this procedure!  
At the end of this Out Of Box Experience (OOBE) will result in the Windows home screen.

- 1** Ensure an input device is present.
  - For an Industrial Box PC connect a keyboard and mouse or a touch monitor.
  - For an Industrial Panel PC touch functionality is available. A keyboard and mouse are not required.
- 2** If a UPS or I/O connector is connected then disconnect it from the Panel PC.
- 3** Power ON the Panel PC.
- 4** Follow the Windows installation procedure.

Pay special attention to the following steps:

- Language  
Select the preferred language in the Language Selection Window  
Select the language carefully, the selected system language can not be changed.
- Legal stuff like license agreements  
Windows 10 and 11: Select **Accept** to accept the combined Windows and OMRON license agreements.
- The **Sign in with Microsoft** Windows.  
Select:
  - Enter your existing Microsoft account when your Industrial Panel PC is connected to a network.
  - Select **Domain join instead** when a local account is preferred.
- Settings  
Windows 10 and 11: Select **Customize** instead of **Use Express settings**.  
Set the settings according to your application environment.
- Create a user account and password and enter the **password hint**



## WARNING

Security setting adjustments should only be performed by the engineer in charge that possesses a thorough understanding of the security settings. Selecting non-recommended security settings can put your system at risk.



### Precautions for Safe Use

- Choose an OS password that is not obvious to prevent unauthorized access.
- Remember the OS user name and password. The product is inaccessible without it.

The Panel PC will automatically restart.

A black screen will be visible for a few seconds and then the Panel PC will boot to the Windows start screen.

Windows 10 and 11 Operating Systems will automatically perform a Windows Update when the Panel PC is connected to the internet. This will keep the Panel PC occupied for a longer period of time, wait until it is completed and the Panel PC automatically reboots.

- 5** Login.
- 6** Check and if necessary adjust the time and the timezone.
- 7** Adjust the backlight, Logo LED, and Status LED brightness to your settings.



#### **Additional Information**

---

Verify that the Panel PC is responding to finger touches on the touchscreen of the product.

---

- 8** Reconnect the UPS connector or I/O connector if applicable.
- 9** Install any third party software and drivers that may be required for your applications.



#### **Precautions for Safe Use**

---

Before operating the system, please make sure the appropriate software is installed and configured. Doing so may prevent unexpected operation.

---

## 5-7 Install Software

---

Install applicable software and activate Windows.



### **Additional Information**

---

Refer to *NY-series Operating Systems and Software Utilities Manual (Cat. No. W616)* for details.

---

## 5-8 Connect UPS

The OMRON S8BA UPS protects the Panel PC from power failures, voltage variations and instantaneous voltage drops. Short power interruptions will be backed up by the UPS and the Panel PC will continue normal operation. The UPS signals the Panel PC when a power failure occurs and then the Panel PC can shutdown normally without data loss. The Panel PC can automatically start up again when the power is restored.

To connect the Panel PC to the OMRON S8BA UPS use one of the following two options:

- The USB connector and the Industrial PC Support Utility Software.  
This is the preferred connection method.  
Refer to *5-8-1 Connect UPS Using the USB Connector* on page 5-54 for more information.
- The I/O connector and the Industrial PC Support Utility or a custom software program.  
Refer to *5-8-2 Connect UPS Using the I/O Connector* on page 5-56 for more information.

### WARNING

The use of an uninterruptible power supply (UPS) allows normal operation to continue even if a momentary power failure occurs, possibly resulting in the reception of an erroneous signal from an external device affected by the momentary power failure. Take external fail-safe measures. Where necessary, monitor the power supply voltage on the system for external devices and use it as an interlock condition.



#### Precautions for Safe Use

- Always use an uninterruptible power supply (UPS) to prevent data loss and other system file integrity issues caused by unexpected power interruption.
- Use an Omron S8BA UPS with the correct revision number to prevent improper system shutdown.
- Correctly perform wiring and setting, and ensure that the shutdown by the UPS can be executed.



#### Additional Information

- The minimum power requirements of the UPS are dependent on the power consumption. Refer to *4-1-3 Power Consumption Specifications* on page 4-7 for power consumption details.
- Refer to [the OMRON website](#) for S8BA specifications or to the *UPS S8BA User's Manual (Cat. No. U702)* for the UPS manual.  
Note that the power consumption details determine the output current/capacity of your UPS.

## 5-8-1 Connect UPS Using the USB Connector

Use the following procedure for a UPS connection using the USB connector.

The Industrial PC Support Utility monitors the UPS status via the USB interface and shuts down the Industrial Panel PC when needed.

For Panel PCs with Windows:

- the drivers for the S8BA UPS are pre-installed
- Installation files and the manual for the UPS Settings Utility are available in the directory D:\OM-  
RON-NY\Installers\ UPS Settings Utility



### Additional Information

Refer to 5-8 *Connect UPS* on page 5-53 for safety details.

Follow the steps below to connect the S8BA UPS with a USB cable and to configure it correctly. Refer to 3-10-10 *UPS* on page 3-36 for more information.

- 1** Ensure the revision number of the UPS is correct.  
Refer to 3-10-10 *UPS* on page 3-36 for more information.
- 2** For Panel PCs that do not have Windows pre-installed: Download the above mentioned software.
- 3** Wire the S8BA UPS.
  - 1) Wire the input of the UPS to the output of the Power Supply.
  - 2) Wire the output of the UPS to the power connector of the Panel PC.
  - 3) Ground the UPS.
  - 4) Connect the USB port of the S8BA UPS to the USB port of the Panel PC using the USB cable provided with the S8BA UPS.

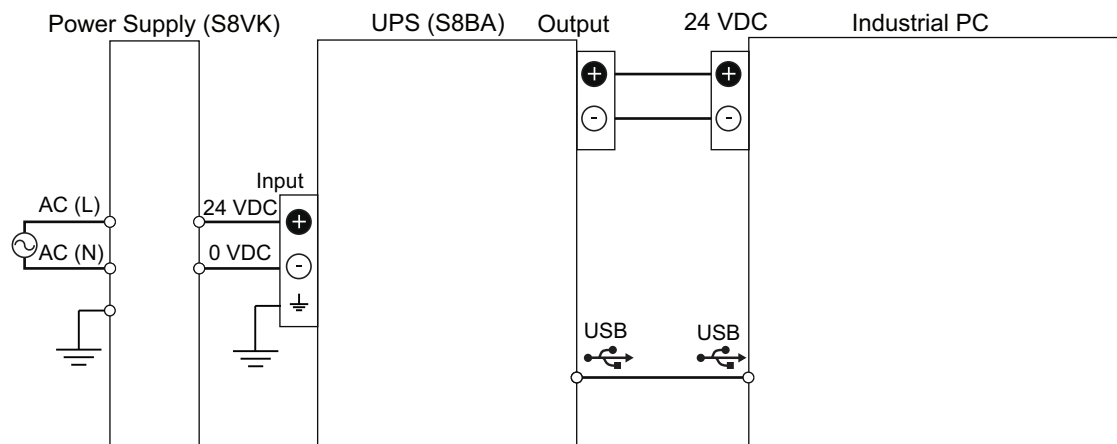

Refer to the *UPS S8BA User's Manual (Cat. No. U702)* for details.  
Refer to 5-4 *Wire* on page 5-31 for wiring details.

- 4** Supply power to the Power Supply.

- 5** Press and hold the UPS power button until **On** appears on the UPS display.
- 6** Power ON the Panel PC and then wait until the device drivers are successfully installed.
- 7** Configure the UPS using the UPS Settings Utility.  
Refer to UPS Setting Utility Instruction Manual for S8BA/BU-2RWL for details.
- 8** Configure the UPS using the Industrial PC Support Utility.  
Refer to *NY-series Operating Systems and Software Utilities Manual (Cat. No. W616)* for details.
- 9** Configure the Panel PC to auto-start after power loss within the BIOS settings.  
Refer to *A-1 BIOS* on page A-2 for BIOS details.
- 10** Simulate a power interruption and confirm a correct shutdown of the Panel PC.
  - Start the Panel PC
  - Start applications
  - Create a power interruption
  - Monitor the shutdown sequence and confirm a correct shutdown sequence

The UPS is connected with USB and correctly configured.

The Panel PC will shut down properly in case of a power supply interruption and restart automatically when the power is restored.



#### Additional Information

---

The default **Input sensitivity setting** is **Standard voltage sensitivity** and this is correct. Do not set this parameter to **Low voltage sensitivity**. Doing so can cause a system malfunction when switching to battery mode.

---

## 5-8-2 Connect UPS Using the I/O Connector

Use the following procedure for a UPS connection using the I/O connector.

The I/O connector of the Industrial Panel PC can receive the power status of the UPS with an input and set the power status of the UPS with an output.



### Additional Information

---

- A UPS connection using the I/O connector in combination with the Industrial PC Support Utility is possible for a Panel PC with a Windows operating system.
  - Without the Industrial PC Support Utility a custom software program is required to shut down the Panel PC when needed. This is required because the Panel PC does not react automatically to the UPS Mode Input.
- 

UPS Drivers and the required software is available.

- For Panel PCs with Windows:
  - the drivers for the S8BA UPS are pre-installed
  - Installation files and the manual for the UPS Settings Utility are available in the directory D:\OMRON-NY\Installers\ UPS Settings Utility
- For all other Panel PCs:
  - the drivers for the S8BA UPS can be downloaded from [this OMRON website](#)
  - Installation files and the manual for the UPS Settings Utility can be downloaded from [this OMRON website](#)

Refer to 5-4-4 *Wire the I/O Connector* on page 5-41 for I/O Connector details.



### Precautions for Safe Use

---

- Always use the recommended uninterruptible power supply (UPS) to prevent data loss and other system file integrity issues caused by unexpected power interruption.
  - Use an Omron S8BA UPS with the correct revision number to prevent improper system shutdown.
  - Correctly perform wiring and setting, and ensure that the shutdown by the UPS can be executed.
- 

Follow the steps below to connect the S8BA UPS to the I/O connector of the Panel PC and to configure it correctly.

- 1** Ensure the revision number of the UPS is correct.  
Refer to *3-10-10 UPS* on page 3-36 for more information.
- 2** Wire the S8BA UPS.
  - 1) Wire the input of the UPS to the output of the Power Supply.
  - 2) Wire the output of the UPS to the power connector of the Panel PC.
  - 3) Ground the UPS.
  - 4) Connect the Contact port of the S8BA UPS to the I/O port of the Panel PC with the connection cable S8BW-C02.

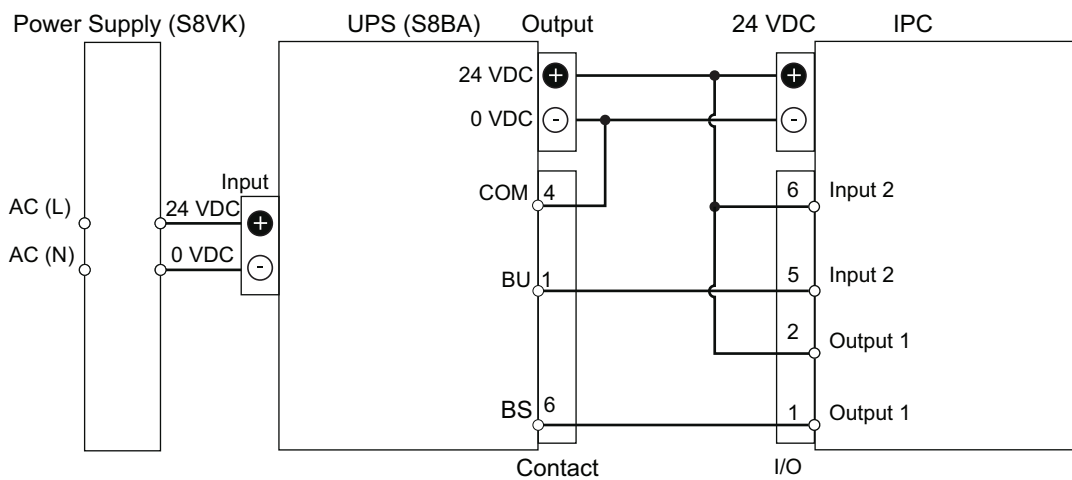

- 3** For a Panel PC with Windows:  
Connect, configure and test the UPS connection with the procedure *Connect UPS - I/O Connector and Industrial PC Support Utility* on page 5-58.

For a Panel PC with another Operating System or when custom software is preferred:  
Connect, configure and test the UPS connection with the procedure *Connect UPS - I/O Connector and Custom Software* on page 5-59.

The UPS is connected using the I/O connector and configured correctly..

## Connect UPS - I/O Connector and Industrial PC Support Utility

Use the following procedure for a UPS connection using the I/O connector in combination with the Industrial PC Support Utility.

The Industrial PC Support Utility is available for Panel PCs with a Windows operating system.



### Additional Information

Refer to *5-8-2 Connect UPS Using the I/O Connector* on page 5-56 and to *5-8 Connect UPS* on page 5-53 for safety details.

For the start of this procedure refer to *5-8-2 Connect UPS Using the I/O Connector* on page 5-56. Follow the steps below to connect the S8BA UPS to the I/O connector of the Panel PC and to configure it correctly.

- 1** Supply power to the Power Supply.
- 2** Press and hold the UPS power button until **On** appears on the UPS display.
- 3** Power ON the Panel PC and then wait until the device drivers are successfully installed.
- 4** Configure the UPS using the UPS Settings Utility.  
Refer to UPS Setting Utility Instruction Manual for S8BA/BU-2RWL for details.
- 5** Configure the UPS using the Industrial PC Support Utility.  
Refer to *NY-series Operating Systems and Software Utilities Manual (Cat. No. W616)* for details.
- 6** Configure the Panel PC to auto-start after power loss within the BIOS settings.  
Refer to *A-1 BIOS* on page A-2 for BIOS details.
- 7** Simulate a power interruption and confirm a correct shutdown of the Panel PC.
  - Start the Panel PC
  - Start applications
  - Create a power interruption
  - Monitor the shutdown sequence and confirm a correct shutdown sequence

The UPS is connected and configured.



### Additional Information

The default **Input sensitivity setting** is **Standard voltage sensitivity** and this is correct. Do not set this parameter to **Low voltage sensitivity**. Doing so can cause a system malfunction when switching to battery mode.

## Connect UPS - I/O Connector and Custom Software

Use the following procedure for a UPS connection using the I/O connector in combination with a custom software program.

The I/O connector of the Industrial Panel PC can receive the power status of the UPS with an input and set the power status of the UPS with an output.

The Panel PC does not react automatically to the UPS Mode Input. **A custom software program is required** to shut down the Panel PC when needed.



### Additional Information

Refer to *5-8-2 Connect UPS Using the I/O Connector* on page 5-56 and to *5-8 Connect UPS* on page 5-53 for safety details.

For the start of this procedure refer to *5-8-2 Connect UPS Using the I/O Connector* on page 5-56. Follow the steps below to connect the S8BA UPS to the I/O connector of the Panel PC and to configure it correctly.

- 1** Power ON the Panel PC.
- 2** Configure the UPS using the UPS Settings Utility.  
Refer to UPS Setting Utility Instruction Manual for S8BA/BU-2RWL for details.
- 3** Configure the Panel PC to auto-start after power loss within the BIOS settings.  
Refer to *A-1 BIOS* on page A-2 for BIOS details.
- 4** Create a software program that monitors the UPS Mode Input and initiates Power OFF of the Panel PC when the UPS Mode Input becomes active.  
If the Panel PC has a Windows operating system then use the Industrial PC System SDK to create the software program.  
Refer to *NY-series Software Development Kit User's Manual* for SDK details.
- 5** Install the created software program.
- 6** Test the created software program and ensure it functions correctly.
- 7** Simulate a power interruption and confirm a correct shutdown of the Panel PC.
  - Start the Panel PC
  - Start applications
  - Create a power interruption
  - Monitor the shutdown sequence and confirm a correct shutdown sequence

The UPS is connected and configured.

## 5-9 Create Backup and Repair Data

---

Ensure the operating system, software and data can always be restored when required. There are different software tools to create a backup and repair data. Select the Backup and Repair procedure or procedures that are most suitable for your situation.



### **Precautions for Correct Use**

---

Refer to *NY-series Operating Systems and Software Utilities Manual (Cat. No. W616)* for the Overview of Recover, Restore and Repair Methods.

---

# 6

## Operating Procedures

This section provides the operating procedures for the Industrial Panel PC.

---

<b>6-1</b>	<b>Touchscreen Operation .....</b>	<b>6-2</b>
6-1-1	Touchscreen Operation - Capacitive Touch.....	6-2
<b>6-2</b>	<b>Power ON .....</b>	<b>6-3</b>
6-2-1	Power ON Using the Power Button .....	6-3
6-2-2	Power ON Using the Power ON/OFF Input.....	6-3
6-2-3	Auto Power ON .....	6-4
<b>6-3</b>	<b>Power OFF .....</b>	<b>6-5</b>
6-3-1	Power OFF Using the Power Button .....	6-5
6-3-2	Power OFF Using Windows Shut Down.....	6-5
6-3-3	Power OFF Using the Power ON/OFF Input.....	6-6
6-3-4	Forced Power OFF Using the Power Button .....	6-6
<b>6-4</b>	<b>React to Product Messages .....</b>	<b>6-7</b>
<b>6-5</b>	<b>React to Windows Messages .....</b>	<b>6-8</b>

## 6-1 Touchscreen Operation

Touchscreen operation is specific for the type of touchscreen installed.

Refer to *6-1-1 Touchscreen Operation - Capacitive Touch* on page 6-2 for details.

### CAUTION

When using a system with multiple touchscreens, multiple users can perform simultaneous operations. Make sure that this can not result in unintended actions.



### 6-1-1 Touchscreen Operation - Capacitive Touch

### WARNING

Water or other liquid present on the touchscreen surface may create false touch behavior and unexpected operation. Wipe away liquid on the touchscreen before operation.



#### Precautions for Correct Use

The touchscreen supports 5 simultaneous touches. When the number of touches is exceeded, not all touch points will be detected.

Capacitive touchscreens have a glass screen. These touchscreens detect a touch using conductivity. The touchscreen supports projected capacitive technology for the touch operation. Only light pressure is required to activate the touch function.

The touchscreen supports following operations:

- Up to 5 simultaneous touches can be detected.
- Multiple simultaneous touch points can be supported in software for advanced touch functions such as zoom, rotation and multiple user interaction.
- The touchscreen can ignore hand-palm touches while still accepting additional correct touches.
- The touchscreen can be operated when wearing gloves. Check correct usage of the gloves before using them.
- Water detection, depending on the product configuration.

Details are available in **Touch input settings** of the Industrial Monitor Utility.

See NY-series Operating Systems and Software Utilities Manual (Cat. No. W616).



#### Additional Information

Refer to *7-1-2 Clean the Touchscreen Surface* on page 7-3 for cleaning details.

## 6-2 Power ON

This section provides Power ON details.



### Precautions for Correct Use

Do not turn ON the power supply to the product when a part of a human body or a conductive object is touching the surface of the touchscreen. Doing so will cause the touchscreen functionality to be disabled. Remove the conductive object and cycle the power supply to restore the touchscreen functionality.

### 6-2-1 Power ON Using the Power Button

Start condition: Power is supplied to the Panel PC and the Panel PC is OFF.

- 1** Press the power button and release within 1 second.  
Refer to *3-3 Power Button* on page 3-12 for the power button location.  
The Panel PC starts and the PWR LED will turn ON.
- 2** Wait until the PWR LED is ON and verify that the ERR LED is OFF.  
The Panel PC is ON and the Operating System, if installed, starts.

### 6-2-2 Power ON Using the Power ON/OFF Input

Start condition: Power is supplied to the Panel PC and the Panel PC is OFF.

- 1** Supply a 24 VDC signal to pin 3 of the Power and I/O connector. This activates the Power ON/OFF input that consists of pins 3 and 4.  
The input signal must remain ON for a minimum of 60 ms and a maximum of 750 ms to be correctly detected by the Panel PC.  
The Panel PC starts and the PWR LED will turn ON.
- 2** Wait until the PWR LED is ON and verify that the ERR LED is OFF.  
The Panel PC is ON and the Operating System, if installed, starts.



### Additional Information

- Refer to *4-2 Connector Specifications* on page 4-26 for connector details.
- Refer to *5-4 Wire* on page 5-31 for wiring details.

### 6-2-3 Auto Power ON

The Panel PC can be configured to start up when power is supplied to the power connector.

The **Power Loss Control** BIOS setting controls this behavior.

Set the Power Loss Control setting to **Turn ON** to activate the Auto Power ON function.



---

#### **Additional Information**

Refer to *A-1 BIOS* on page A-2 for BIOS details.

---

## 6-3 Power OFF

This section provides Power OFF details.

Before following power OFF procedures below, check that the Industrial Panel PC is ON by examining the LED indicators on the Panel PC.

### 6-3-1 Power OFF Using the Power Button

- 1** Ensure all programs are closed.  
If required close all active programs.
- 2** Press and release the power button on the Industrial Panel PC within 1 second.  
The Industrial Panel PC will shutdown.  
Note that this behaviour of can be reconfigured with the Power Options settings.  
Refer to 3-3 *Power Button* on page 3-12 for power button location information.
- 3** Wait until the PWR LED is OFF.

The Panel PC is powered OFF.



#### Additional Information

The Panel PC will restart automatically if a UPS is connected to the I/O connector of the Panel PC. Use the Power button of the UPS or remove the input power from the UPS for a normal shutdown of the Panel PC.

### 6-3-2 Power OFF Using Windows Shut Down

- 1** Ensure all programs are closed.  
If required close all active programs.
- 2** Select the Windows **Shutdown** button.  
To display the **Shutdown** button select the **Windows** button and then the **Power** button.  
The Industrial Panel PC will shut down.
- 3** Wait until the PWR LED is OFF.  
The Industrial Panel PC is powered OFF.

### 6-3-3 Power OFF Using the Power ON/OFF Input

- 1** Ensure all programs are closed.  
If required, close all active programs.
- 2** Supply a 24 VDC signal to pin 3 of the Power and I/O connector. This activates the Power ON/OFF input that consists of pins 3 and 4.  
The input signal must remain ON for a minimum of 60 ms and a maximum of 750 ms to be correctly detected by the Industrial Panel PC.  
The Industrial Panel PC will shutdown.  
Note that this behaviour can be reconfigured with the Power Options settings.
- 3** Wait until the PWR LED is OFF.  
The Panel PC is powered OFF.



#### Additional Information

- Refer to *4-2 Connector Specifications* on page 4-26 for connector details.
- Refer to *5-4 Wire* on page 5-31 for wiring details.

### 6-3-4 Forced Power OFF Using the Power Button



#### Precautions for Safe Use

Press the power button for several seconds to force the product shutdown. Always back up files in the planned way to prevent data loss or system file corruption.

- 1** Ensure all programs are closed.  
If required, close all active programs to prevent losing unsaved data.
- 2** Press and hold the power button on the Panel PC for 5 to 10 seconds.  
Refer to *3-3 Power Button* on page 3-12 for power button location information.  
The Panel PC will power OFF.  
Any optional operating system settings related to power OFF will be disregarded.
- 3** Wait until the PWR LED is OFF.  
The Panel PC is powered OFF.  
Confirm normal operation and check all product settings because unsaved data was lost.

## 6-4 React to Product Messages

The Industrial Panel PC uses the Industrial PC Tray Utility icon (A) in the system tray area (B) of Windows to present Warnings and Errors.

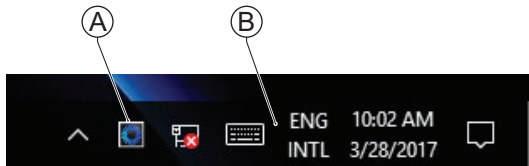

Check the Industrial PC Tray Utility icon for a Warning or Error symbol.

A Warning or Error symbol displayed on the Industrial PC Tray Utility icon indicates a product message.

To react to a product message:

- 1** Select the Industrial PC Tray Utility icon.  
A pop-up window will appear.
- 2** Read the message available in the pop-up.
- 3** Refer to *7-2-1 Warning and Error Messages* on page 7-5 for all details on the message.  
Perform the actions presented for the message until the Warning or Error is resolved.

The product messages for the Industrial Panel PC are resolved.

## 6-5 React to Windows Messages

Windows messages are available from the system tray area.

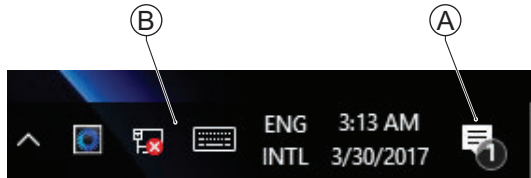

Windows 10

The Windows Action Center icon (A) is available in the system tray area (B).



Windows 11

Notifications appear when selecting the date/time (B) in the system tray area (A).

A Warning or Error symbol displayed indicates a Windows message.

To react to a Windows message:

- 1 Display the Windows message.

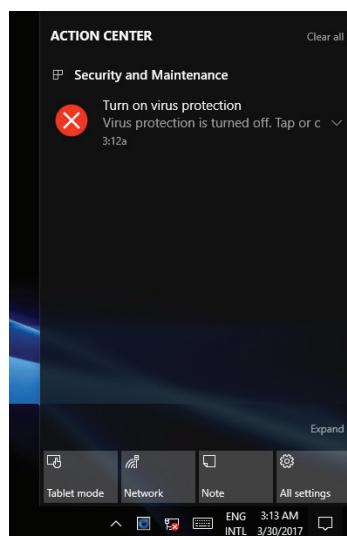

Windows 10

Select the Windows Action Center icon.

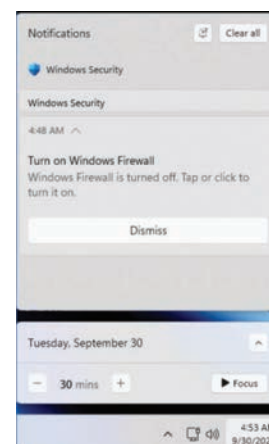

Windows 11

Select the date/time.

A pop-up window will appear.

- 2 Read the message available in the window.
- 3 Perform the actions until each Warning or Error is resolved.

The Windows messages are resolved.



# Maintenance

This section provides an overview of all maintenance tasks for the Industrial Panel PC.

---

<b>7-1</b>	<b>Preventive Maintenance .....</b>	<b>7-2</b>
7-1-1	Preventive Maintenance Schedule .....	7-2
7-1-2	Clean the Touchscreen Surface .....	7-3
7-1-3	Clean the Panel PC .....	7-4
7-1-4	Check the Gasket Seal .....	7-4
7-1-5	Minimize LCD Image Retention .....	7-4
<b>7-2</b>	<b>Corrective Maintenance .....</b>	<b>7-5</b>
7-2-1	Warning and Error Messages .....	7-5
7-2-2	Remove the Cover .....	7-7
7-2-3	Replace the Fan Unit .....	7-8
7-2-4	Replace the CJ1W Battery .....	7-10
7-2-5	Replace a Drive .....	7-15
7-2-6	Replace the PCIe Card .....	7-20
7-2-7	Replace the CFast Card .....	7-25

# 7-1 Preventive Maintenance

Preventive Maintenance covers all actions that prevent downtime.

## 7-1-1 Preventive Maintenance Schedule

Prevent unscheduled downtime with the following preventive maintenance schedule.

Daily	Reference
Check Industrial Panel PC status	<ul style="list-style-type: none"> <li>Refer to <i>7-2-1 Warning and Error Messages</i> on page 7-5 for all available messages.</li> <li>Refer to <i>3-2 LED Indicators</i> on page 3-8 for LED details.</li> </ul>
Monitor storage devices that do not comply to the Omron specifications	Refer to <i>Storage Device Considerations</i> on page 3-30 for details.
Clean the display	Refer to <i>7-1-2 Clean the Touchscreen Surface</i> on page 7-3 for display cleaning details.

Weekly	Reference
Clean the Panel PC	Refer to <i>7-1-3 Clean the Panel PC</i> on page 7-4 for cleaning details.
Ensure you have the latest software updates	Refer to <i>NY-series Operating Systems and Software Utilities Manual (Cat. No. W616)</i> for details.

When changing applications or configurations	Reference
Create a backup of the Industrial Panel PC	Refer to <i>NY-series Operating Systems and Software Utilities Manual (Cat. No. W616)</i> for backup details.

Periodically but at least every 6 months	Reference
Check the ambient environment: <ul style="list-style-type: none"> <li>Temperature and humidity within specifications</li> <li>Noise sources not close to the Industrial Panel PC</li> </ul>	Refer to <i>4-4 Environmental Specifications</i> on page 4-42 for environmental specifications.
Check installation: Industrial Panel PC mounted securely	Refer to <i>5-3 Mount</i> on page 5-14 for installation details.
Check wiring and connections: <ul style="list-style-type: none"> <li>Cable connectors fully inserted and locked</li> <li>No damaged wiring or connectors</li> </ul>	Refer to <i>5-4 Wire</i> on page 5-31 for wiring details. Refer to <i>5-5 Connect</i> on page 5-44 for connection details.
Check the gasket behind the monitor rim	Refer to <i>7-1-4 Check the Gasket Seal</i> on page 7-4 for gasket details.
Check the display: <ul style="list-style-type: none"> <li>Brightness is sufficient</li> <li>No touch offset</li> </ul>	Refer to <i>NY-series Operating Systems and Software Utilities Manual (Cat. No. W616)</i> for details.

Periodically but at least every 6 months	Reference
For models with a replaceable battery: <ul style="list-style-type: none"> <li>• Check the battery replacement date.</li> <li>• Replace the battery before the replacement date.</li> </ul>	<ul style="list-style-type: none"> <li>• Refer to 7-2-4 <i>Replace the CJ1W Battery</i> on page 7-10 to replace the battery.</li> </ul>
Check the backup and repair media.	Refer to <i>NY-series Operating Systems and Software Utilities Manual (Cat. No. W616)</i> for details.

When the Industrial Panel PC is not powered for 6 months	Reference
For a cooling layer with removable cover and active cooling: <ul style="list-style-type: none"> <li>• Confirm both fans rotate immediately after Power ON.</li> <li>• Replace the Fan Unit when the fans do not rotate smoothly.</li> </ul>	Refer to 7-2-3 <i>Replace the Fan Unit</i> on page 7-8 to replace the Fan Unit.

## 7-1-2 Clean the Touchscreen Surface

Clean the touchscreen surface of the Panel PC when necessary to keep it in the best operating condition.

- Ensure the Panel PC is OFF before cleaning.
- Wipe the Panel PC daily with a dry, soft cloth. If the touchscreen is very dirty and you try to clean it with a dry cloth, you may scratch the surface. Use a damp cloth first to remove the dirt.
- When a spot cannot be removed with a dry cloth, dampen the cloth with a neutral cleanser, wring out the cloth and wipe the touchscreen surface.
- Remove all residue from gum, vinyl or tape when cleaning.



### Precautions for Correct Use

Turn OFF the product or disable the touchscreen for cleaning.



### Additional Information

Allowed cleaning materials for the touchscreen surface:

- Isopropyl alcohol
- Detergents between pH 5 and pH 8  
Rinse with demineralized water after cleaning
- Demineralized water

### 7-1-3 Clean the Panel PC

Clean the Panel PC periodically in order to keep it in the best operating condition.  
Wipe the Panel PC with a dry, soft cloth.



#### Precautions for Safe Use

---

Do not use corrosive substances to clean the product.  
Doing so may result in the failure or malfunction.

---

### 7-1-4 Check the Gasket Seal

The gasket prevents liquid from penetrating the Panel PC.  
A damaged gasket can lead to Panel PC or other hardware failures.

Check the gasket on all 4 sides of the Panel PC.  
The gasket should be visible as a thin black line that has no dents or damage.

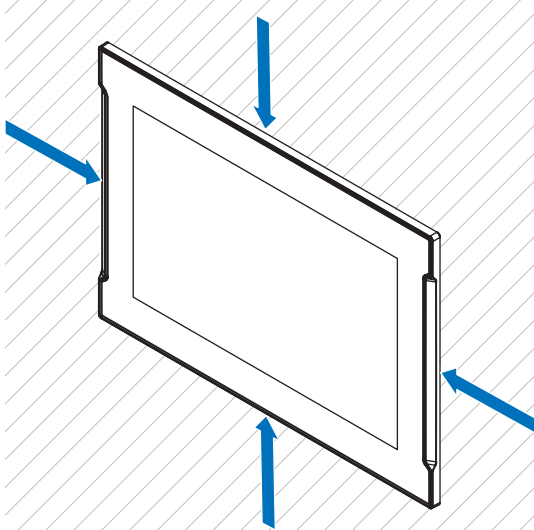

#### Precautions for Safe Use

---

As the gasket will deteriorate, shrink, or harden depending on the operating environment, periodic inspection is necessary.

---

### 7-1-5 Minimize LCD Image Retention

All LCD displays will display image retention effects when used in less optimal conditions.

To minimize the effects of image retention:

- Prevent static text and static images with high contrast
- Switch OFF the display when not in use
- Use a screen saver

## 7-2 Corrective Maintenance

Corrective maintenance covers all actions to correct problems that cause downtime.

WARNING

Do not attempt to disassemble, repair or modify the product in any way. Doing so may result in malfunction or fire.



Contact your local OMRON representative if the corrective maintenance actions did not solve the problem.

### 7-2-1 Warning and Error Messages

Warning and Error messages are provided by the Industrial Panel PC when there is a potential problem that may cause downtime. This section provides details about these messages.

Warning messages inform you about a situation that will lead to downtime of the Industrial Panel PC.

Error messages inform you about what caused the downtime of the Industrial Panel PC.

The following message channels are available.

#### LED Indicators

The ERR LED indicator provides information on warnings and errors.

#### Industrial PC Support Utility

The Industrial PC Support Utility provides information on warnings and errors.

The Industrial PC Support Utility indicates:

- Internal temperature above setting  
Check the status of the Fan Unit and check the ambient conditions.
- Low revolution speed of the Fan Unit
  - Check for excessive dust on the fans and in the Fan Unit.
  - If required replace the Fan Unit.
- Low battery status  
Replace the battery.
- The status of the UPS.

## Windows Action Center / Notifications

---

Windows related warnings and errors are available via the taskbar. Refer to *6-5 React to Windows Messages* on page 6-8 for details.

Relevant Windows information messages are security and maintenance issues. Some examples:

- Virus protection (Important)  
Windows did not find anti-virus software on this computer.
- Windows Update (Important)  
Windows Update is not set up for this computer.
- Set up backup  
Your files are not being backed up.

## Windows Pop Up Window

---

Windows Pop Up windows provide information on Windows issues.

An example of a Windows Pop Up

- Close programs to prevent information loss.



To solve this change the paging file size.

## 7-2-2 Remove the Cover

Applicable for products with a cooling layer that has a removable Cover.

The Cover of the cooling layer provides access to the following items.

- Battery
- Fan Unit (applies to products with active cooling)

The inside of the Cover contains a label with the battery replacement date.

No tools are required to open the Cover.

Use the following procedure to remove the Cover of the Panel PC.

- 1 Power OFF your Panel PC if it has active cooling.



### Precautions for Safe Use

Do not remove the fan cover while the power is ON. Contact with the rotating fan may result in injury.

- 2 Remove the Cover.

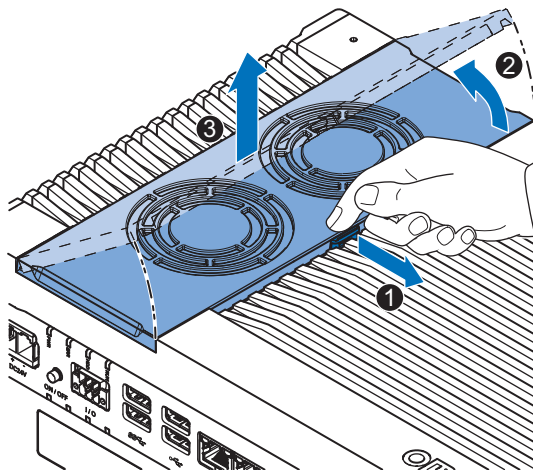

- 1) Pull the lever ① to unlock the Cover.
- 2) Lift the side ② to tilt the Cover.
- 3) Remove ③ the complete Cover.

The Cover is removed.

To mount the Cover, position the side of the Cover in the Panel PC and push the cover in place.

The lever will lock in place.

### 7-2-3 Replace the Fan Unit

The fans are mounted in the Fan Unit.  
Use the following procedure to replace the Fan Unit.



#### Precautions for Safe Use

---

If the storage period of the replacement fan exceeds 6 months, check the performance of the Fan Unit directly after replacement.

---



#### Additional Information

---

Refer to *3-9-2 Fan Unit* on page 3-25 for the model.

---

- 1** Power OFF the Panel PC.
- 2** Remove the Cover of the Panel PC.



#### Additional Information

---

Refer to *7-2-2 Remove the Cover* on page 7-7 for the cover removal procedure.

---

- 3** Disconnect the Fan Connectors from the board.

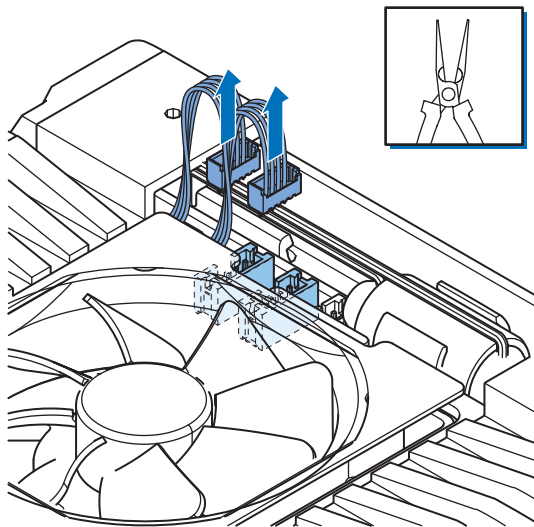

#### 4 Replace the complete Fan Unit.

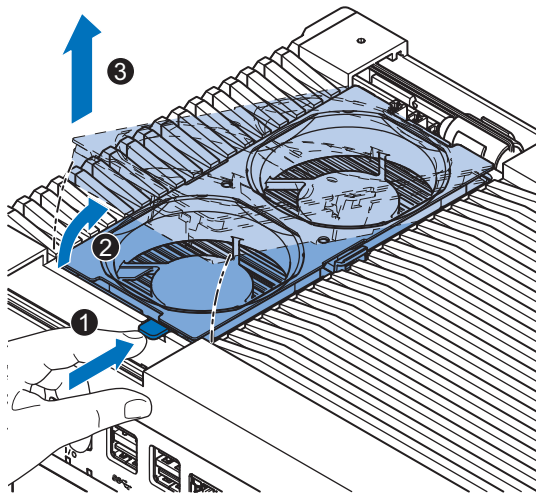

- 1) Push the lever ① to unlock the Fan Unit.
- 2) Lift the lever to tilt ② the Fan Unit.
- 3) Remove ③ the complete Fan Unit.

#### 5 Insert the new Fan Unit in the Panel PC.

Ensure the end of the Fan Unit (A) is positioned under the fan guide (B).

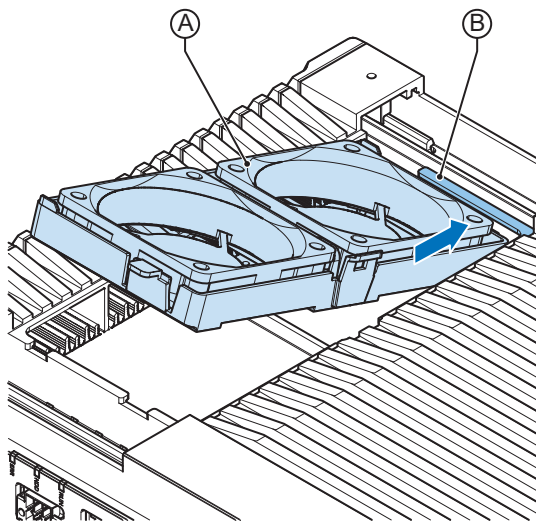

#### 6 Connect the Fan Connectors to the board.

#### 7 Mount the Cover.

#### 8 Power ON the system.

Confirm both fans rotate immediately after Power ON.

The fans are replaced and the alarm is automatically reset.

## 7-2-4 Replace the CJ1W Battery

Use the following information to replace the CJ1W Battery.



---

### Precautions for Safe Use

---

- The Battery may leak, rupture, heat, or ignite. Never short-circuit, charge, disassemble, heat, or incinerate the Battery or subject it to strong shock.
  - Dispose of any Battery that has been dropped on the floor or otherwise subjected to excessive shock. Batteries that have been subjected to shock may leak if they are used.
  - UL standards require that only an experienced engineer replace the Battery. Make sure that an experienced engineer is in charge of Battery replacement.
- 



---

### Precautions for Correct Use

---

- Always touch a grounded piece of metal to discharge static electricity from your body before starting an installation or maintenance procedure.
  - Make sure to use a battery of the correct type and install the battery properly.
  - Apply power for at least five minutes before changing the battery. Mount a new battery within five minutes after turning OFF the power supply. If power is not supplied for at least five minutes, the clock data may be lost. Check the clock data after changing the battery.
  - Turn ON the power after replacing the battery for a product that has been unused for an extended period of time. Leaving the product unused without turning ON the power even once after the battery is replaced may result in a shorter battery life.
- 



---

### Additional Information

---

- Refer to *3-9-1 Battery* on page 3-25 for the battery model.
-

## Replace CJ1W Battery in the Cooling Layer

For models with a cooling layer that has a removable cover.

Use the following procedure to replace the battery:

- 1** Power OFF the Panel PC.
- 2** Remove the cover.  
Refer to 7-2-2 *Remove the Cover* on page 7-7 for more details.
- 3** Lift the battery **1** from the compartment.
- 4** Disconnect the battery from the battery connector **2**.

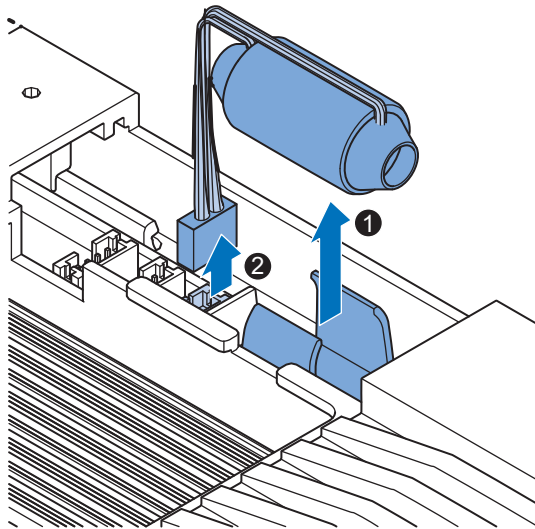

- 5** Connect the new battery to the battery connector.
- 6** Place the new battery in the Panel PC.  
Ensure the wires are at the side of the battery and not on top of the battery. If the wires are on top of the battery this might make closing and opening the cover more difficult.
- 7** Write the next date of replacement on the label at the inside of the cover.

Be sure to replace the battery within 5 minutes.	
Next date of replacement	
1	<input type="text"/>
2	<input type="text"/>
3	<input type="text"/>
4	<input type="text"/>



### Additional Information

Refer to 3-9-1 *Battery* on page 3-25 for lifetime of the battery.

- 8** Mount the cover.
- 9** Power ON the Panel PC.
- 10** Check the Date and Time in the operating system.  
Correct the Date and Time if this is required.
- 11** Dispose of the battery according to local ordinances as they apply.



廢電池請回收 A battery is chemical waste.

The battery in the cooling layer is replaced.

## Replace CJ1W Battery in the Base Layer

For models with the battery in the Base Layer behind a removable cover.

Use the following procedure to replace the battery:

- 1** Power OFF the Panel PC.
- 2** Remove the two screws that are marked with "open" at the backside of the product and open the battery cover.

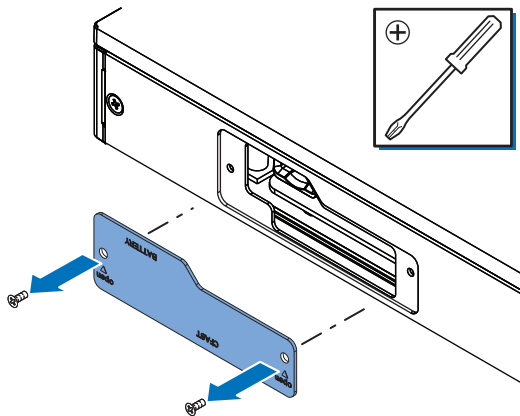

- 3** Pull the battery **1** from the battery holder and disconnect the battery from the battery connector **2**.

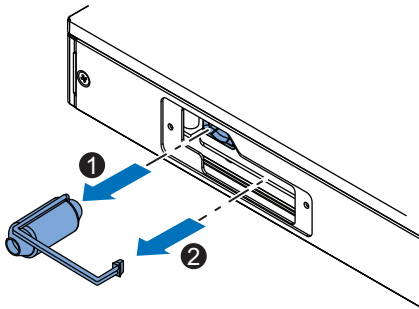

- 4** Connect the new battery to the battery connector **2** and then insert the new battery **1** in the battery holder.

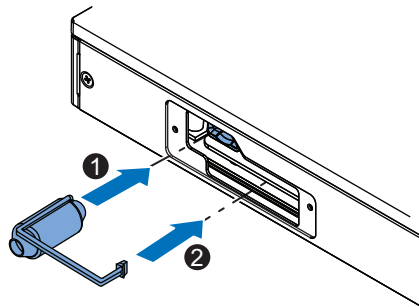

Ensure the wires are flat and inside the unit. If the wires are e.g. on top of the battery this might make closing and opening the cover more difficult.

- 5** Write the next date of replacement on the label at the inside of the cover.

Be sure to replace the battery within 5 minutes.	
Next date of replacement	
1	
2	
3	
4	



### Additional Information

Refer to 3-9-1 *Battery* on page 3-25 for lifetime of the battery.

- 6** Mount the cover.

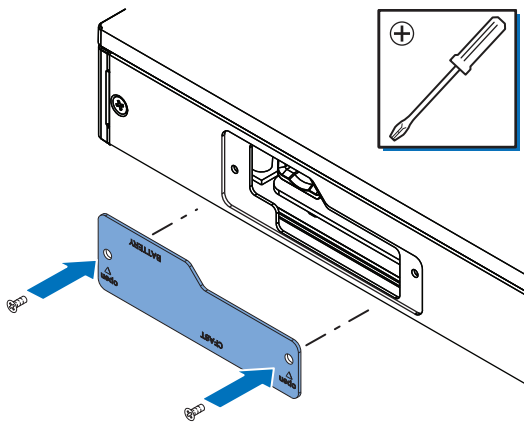

- 7** Power ON the Panel PC.
- 8** Check the Date and Time in the operating system.  
Correct the Date and Time if this is required.
- 9** Dispose of the battery according to local ordinances as they apply.



廢電池請回收 A battery is chemical waste.

The battery in the base layer is replaced.

## 7-2-5 Replace a Drive

Use the following procedure to replace a drive.

Prepare the new drive.



### Additional Information

- Refer to *1-4 Product Configuration Panel PC* on page 1-5 for the installed drive model.
- Refer to *3-10-4 HDD and SSD Storage Devices* on page 3-29 for the available drive models.
- Refer to *4-1-7 Storage Device Specifications* on page 4-17 for drive specifications.

To replace a drive:

- 1 Power OFF the Panel PC.
- 2 Remove the drive cover.

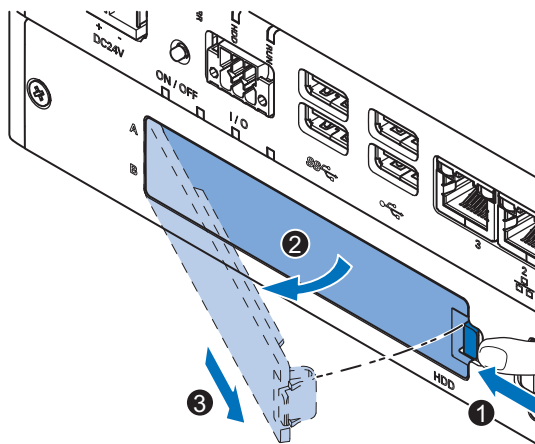

- 1) Push the lock lever ①.
- 2) Tilt the cover ②.
- 3) Remove the drive cover ③.



### Additional Information

- Refer to *3-7 Drive Bays* on page 3-23 for the location of the drive cover.
- The Panel PC has 2 drive bays, marked with "A" and "B" at the left side of the drive cover. Take note of the bay position for the drive that is being removed and do not place a drive in the incorrect bay.

- 3** Pull the metal shielding cover out of the Panel PC.

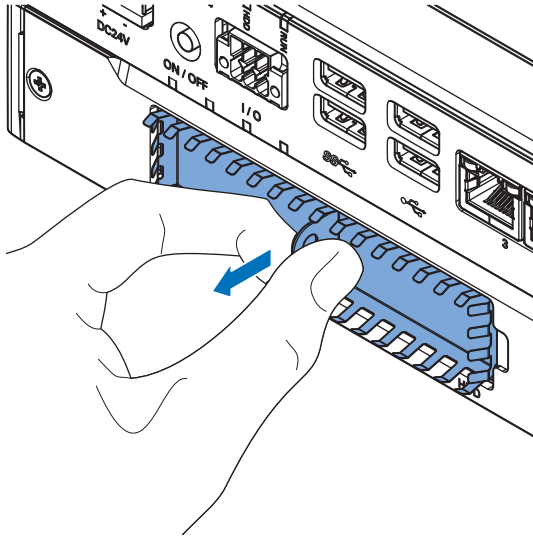

- 4** Insert the drive cover in the drive bracket bay **1** and move it down **2** so that it locks in the drive bracket.

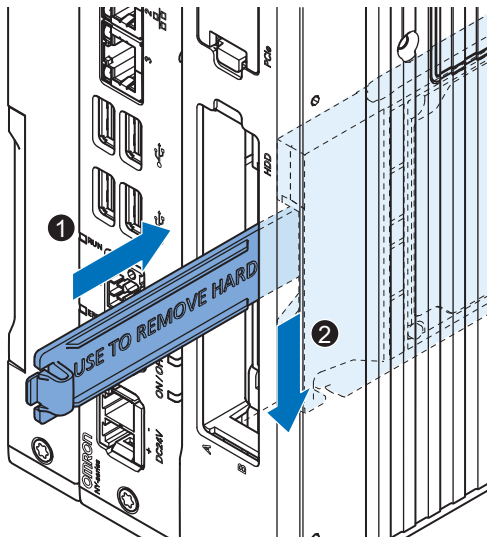

- 5** Remove the drive bracket from the Panel PC using the drive cover.

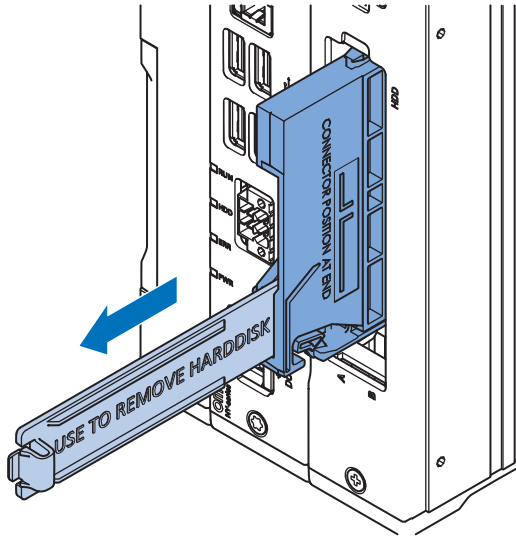

- 6** Remove the 4 mounting screws **1** and then remove the drive **2** from the drive bracket.

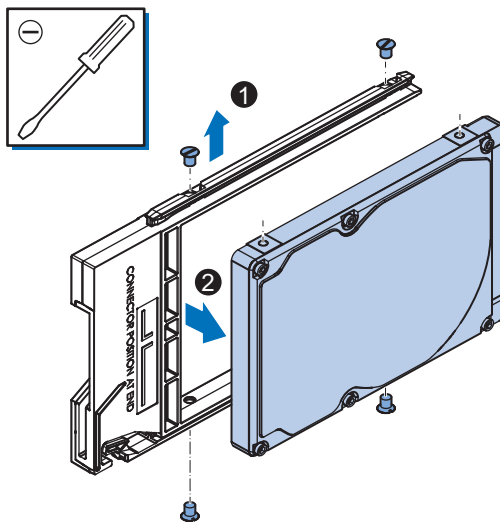

- 7** Align the connectors of the replacement drive as shown **(A)** on the bracket. Then insert the replacement drive **(1)** in the bracket and insert the 4 mounting screws **(2)**. Tighten these screws with a torque of 0.35 N·m.

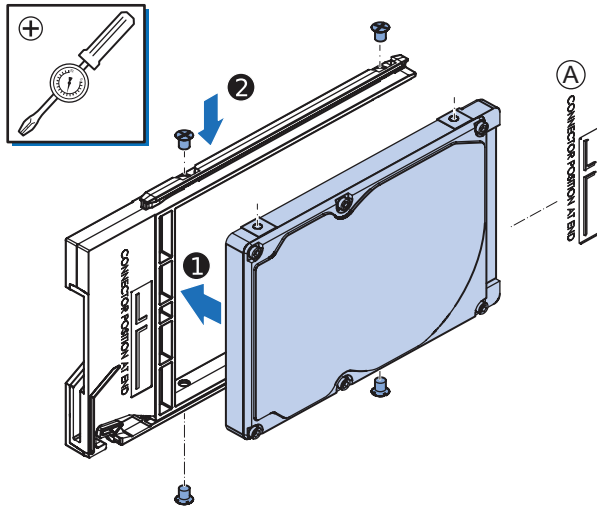

- 8** Insert the bracket with the replacement drive into the correct bay of the Panel PC. Ensure the bracket is completely in the Panel PC with an extra push.

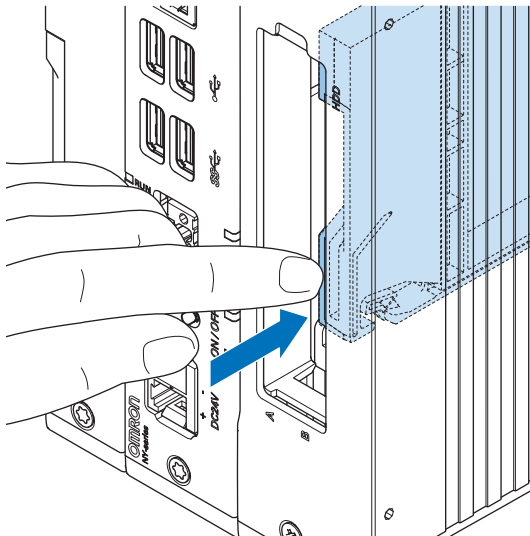

The drive bracket will lock into place when it is fully inserted.

**9** Insert the metal shielding cover.

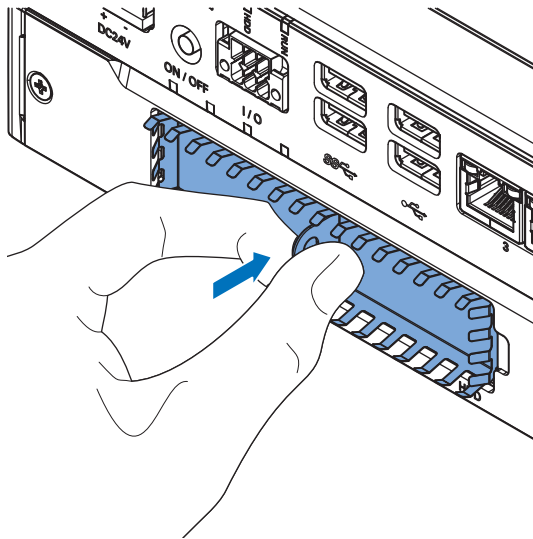

**10** Mount the drive cover.  
The lock lever will click when closed correctly.

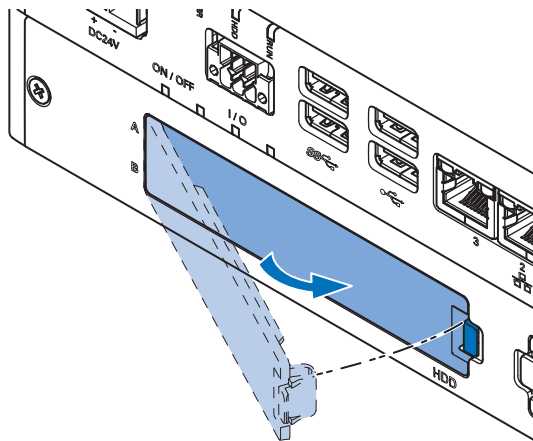

**11** Restore the drive data.

- For an Industrial PC with a Windows operating system refer to the restore procedure in the section *Corrective Maintenance* to restore data.
- For an IPC without Operating System restore the drive data from a backup.

The drive is replaced.

## 7-2-6 Replace the PCIe Card

Use the following procedure to replace the PCIe Card.

Prepare:

- The PCIe Card



### Additional Information

Refer to 4-1-8 *PCIe Card Specifications* on page 4-21 for PCIe specifications.

- The PCIe Card mounting materials: Card Clip and Card Support

These are supplied with the Industrial Panel PC.

To replace the PCIe Card:

- 1** Power OFF the system.
- 2** Unmount the Panel PC.
- 3** Remove the two crosshead screws **1** indicated with "open" and then pull up **2** the PCIe Drawer.

The indent at the side of the drawer will help you to pull the drawer from the Panel PC.

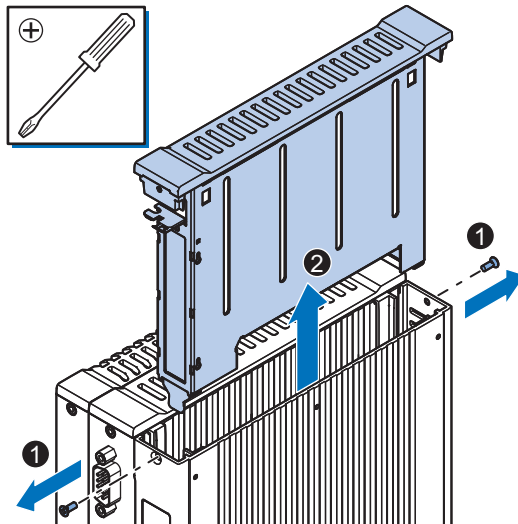

- 4** Push the notch **1** at the bottom of the Card Support up and rotate **2** the Card Support. Slide the Card Support **3** away from the card to create space and to remove it.

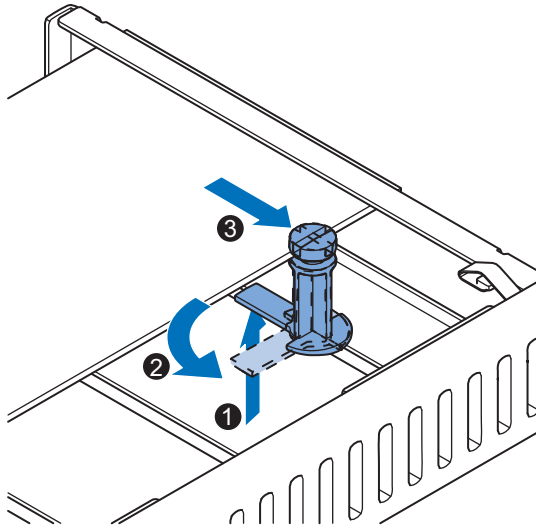

- 5** Remove the Card Clip from the PCIe Drawer. There are two types of Card Clips available. Use the steps applicable to your type.

## CAUTION

When installing or removing a PCIe card, avoid touching the sharp edges of the sheet metal frame tab. Injury may result.

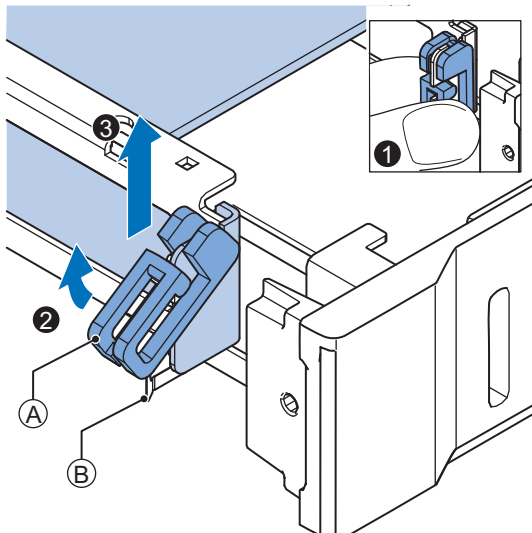

(A) Card Clip

(B) Sheet metal frame tab

Grip the Card Clip (A) on the sides **1**. Pull the middle of the Card Clip to unlock it **2** and remove it **3** from the PCIe Drawer.

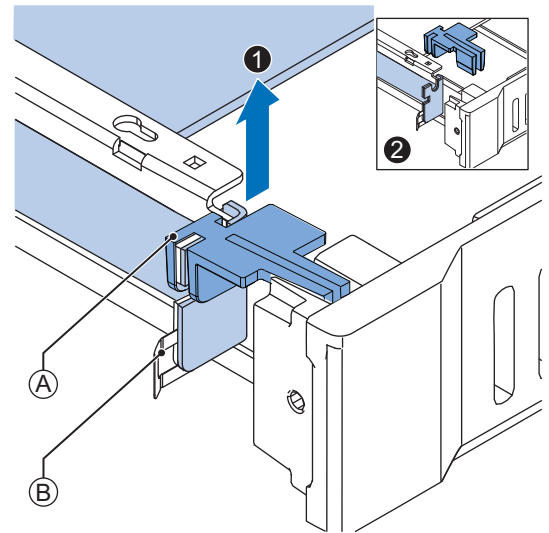

(A) Card Clip

(B) Sheet metal frame tab

Grip the Card Clip (A) on the sides. Lift the Card Clip **1** and remove it **2** from the PCIe Drawer.

- 6** Remove the PCIe Card from the PCIe Drawer.

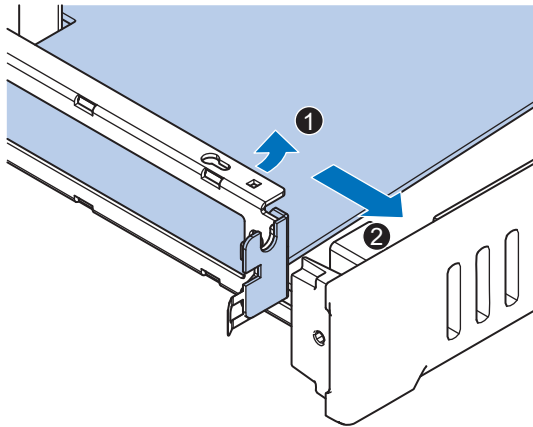

The PCIe Card is now removed.

- 7** Place the replacement PCIe Card in the PCIe Drawer.

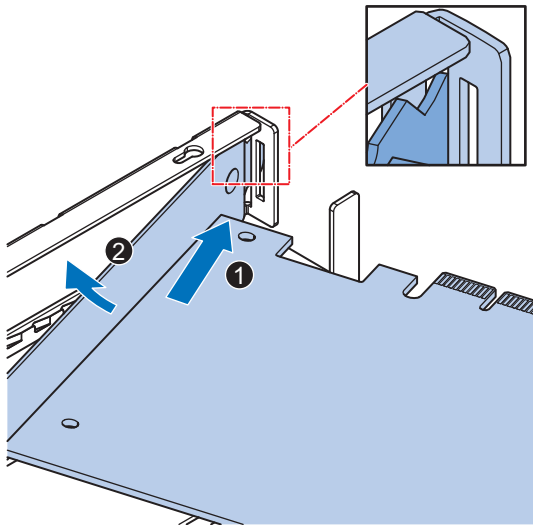

Ensure the PCIe Card is inserted into the correct opening.

- 8 Place the Card Clip (A) in the PCIe Card and PCIe Drawer.

There are two types of Card Clips available. Use the steps applicable to your type.

## CAUTION

When installing or removing a PCIe card, avoid touching the sharp edges of the sheet metal frame tab. Injury may result.

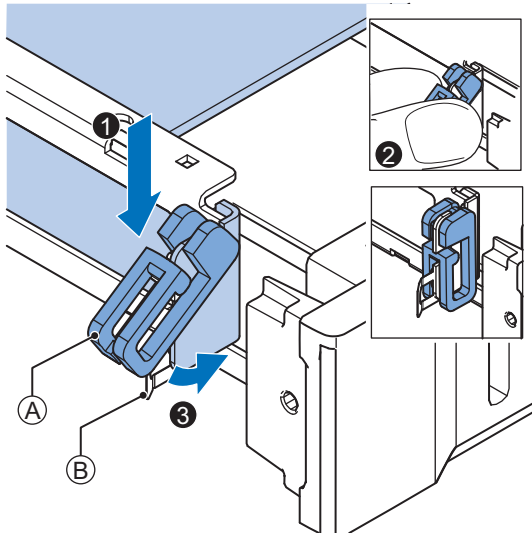

(A) Card Clip

(B) Sheet metal frame tab

Place the Card Clip (A) in the PCIe Card and PCIe Drawer (1), grip the Card Clip on the sides (2) and then rotate the Clip (3) to lock it in place.

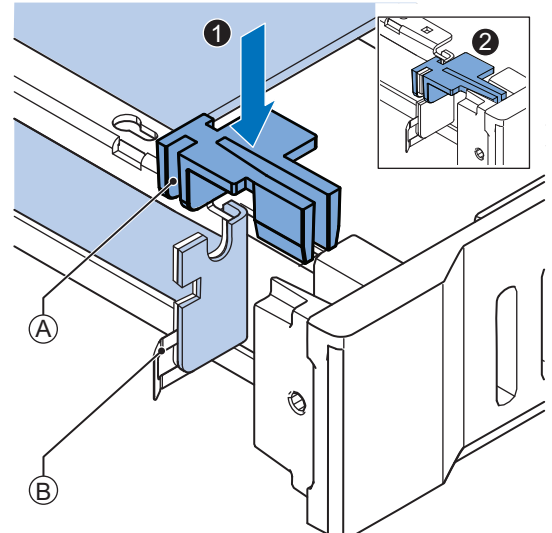

(A) Card Clip

(B) Sheet metal frame tab

Place the Card Clip (A) in the PCIe Card and PCIe Drawer and push it down (1) to lock it in place (2).

- 9** Slide the Card Support **1** so that it supports the side of the PCIe Card.  
Rotate the Card Support **2** to lock it in place.

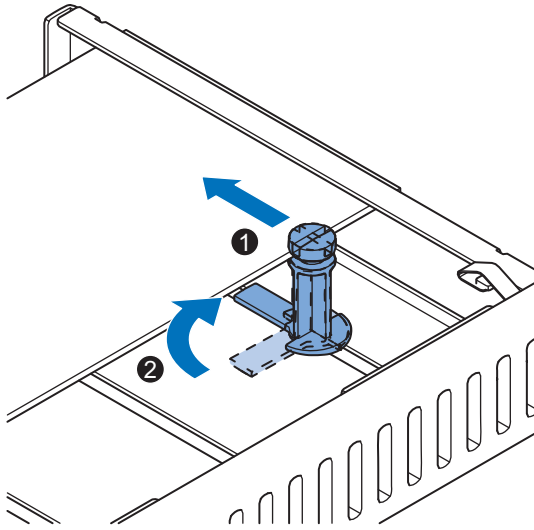

Ensure the Card Support contacts the PCIe Card with the small groove so that there is support below and above the PCIe Card.

- 10** Insert the PCIe Drawer in the Panel PC and then insert the two crosshead screws that hold the PCIe Drawer in place.

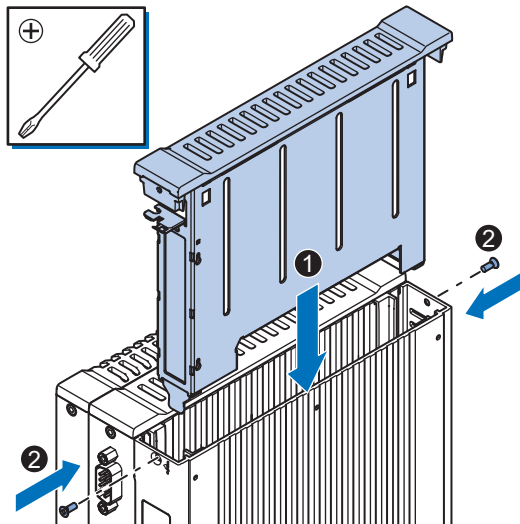

- 11** Remount the Panel PC.

- 12** Confirm normal operation.

The PCIe Card is replaced.

## 7-2-7 Replace the CFast Card

Use the following procedure to replace the CFast Card.

Prepare the new CFast Card.



### Additional Information

- Refer to *1-4 Product Configuration Panel PC* on page 1-5 for the installed CFast Card model.
- Refer to *3-10-3 CFast Cards* on page 3-28 for the available CFast Card models.
- Refer to *CFast Card Specifications* on page 4-20 for specification details.

To replace the CFast Card:

- 1** Power OFF the Panel PC.
- 2** Remove the CFast Card slot cover.

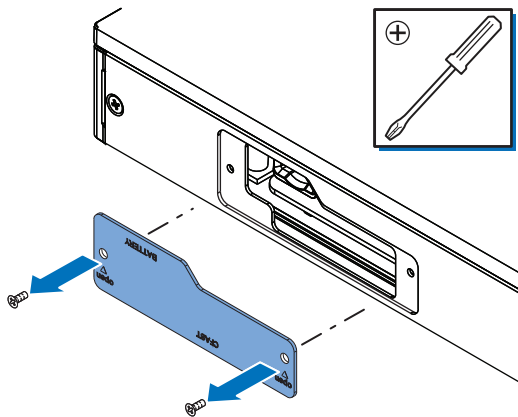

- 1) Remove the two screws that are marked with "open" **1**.
- 2) Remove the cover **2**.

- 3** Pull the plastic Pull Tab **(A)** to remove the CFast Card **(B)** from the Panel PC.

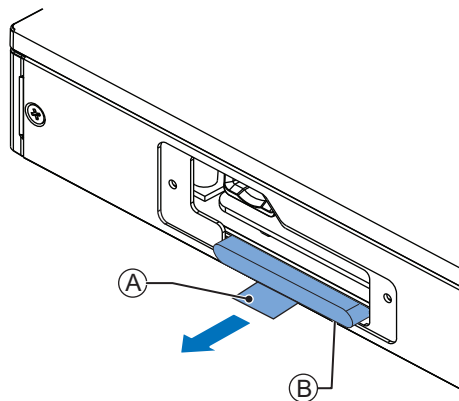

- 4** Insert the replacement CFast Card (A) into the slot of the Panel PC.

Ensure the CFast Card (A) is completely in the Panel PC.

If the CFast Card can not go in completely then the CFast Card orientation is incorrect. Remove the CFast Card, turn it upside down and reinsert it. Ensure the CFast Card (A) is completely in the Panel PC.

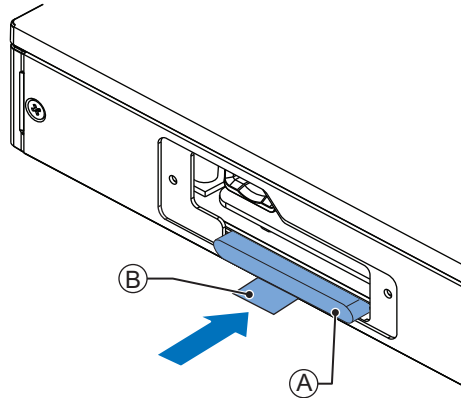

Fold the plastic Pull Tab (B) up so it stays inside the slot area.

- 5** Mount the CFast Card slot cover.

Place the slot cover (1) and then mount the screws (2).

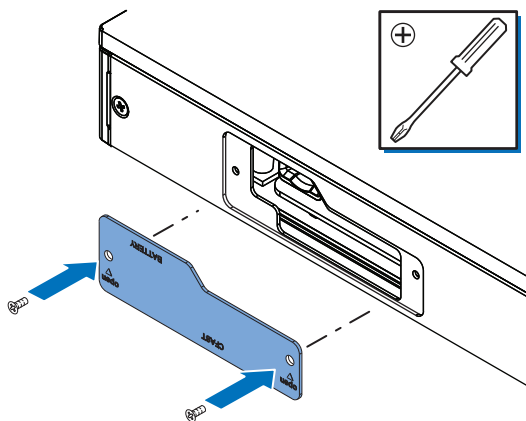

- 6** Restore the drive data from a backup.

Refer to *NY-series Operating Systems and Software Utilities Manual (Cat. No. W616)* for details.

The CFast Card is replaced.



# Appendices

---

---

<b>A-1</b>	<b>BIOS</b> .....	<b>A-2</b>
A-1-1	BIOS Overview .....	A-2
A-1-2	BIOS for 4 <sup>th</sup> generation CPUs .....	A-5
A-1-3	BIOS for 7 <sup>th</sup> generation CPUs .....	A-14
A-1-4	BIOS for 11 <sup>th</sup> generation CPU - CVWNA111 CVWNR111 CVWGR111 .....	A-44
A-1-5	BIOS for 11 <sup>th</sup> generation CPU - CQWGA111 .....	A-53
A-1-6	BIOS for Atom CPU - 1AWGR113 .....	A-61
A-1-7	BIOS for Atom CPU - 3AWNR113 .....	A-67
<b>A-2</b>	<b>DVI Connector Pin Details</b> .....	<b>A-76</b>
A-2-1	DVI-I Connector Pin Details .....	A-76
A-2-2	DVI-D Connector Pin Details .....	A-77
<b>A-3</b>	<b>RS-232C Connector Pin Details</b> .....	<b>A-79</b>

# A-1 BIOS

This section provides the BIOS information of the Industrial Panel PC.

## WARNING

Changing BIOS information is only allowed for the engineer in charge that possesses a thorough understanding of the BIOS settings because it can change the behavior of the product.



### A-1-1 BIOS Overview

The BIOS contains settings that influence the behavior of the Industrial Panel PC.

BIOS settings are specific for your CPU type.

Refer to *1-4 Product Configuration Panel PC* on page 1-5 for CPU details.

The touchscreen functionality is not functional when working in BIOS.

Ensure a USB keyboard is connected.

### BIOS Setup Program

Press the **DEL** key repeatedly directly after Power ON to access the BIOS Setup Program.



#### Additional Information

For 4<sup>th</sup>, 6<sup>th</sup> and 7<sup>th</sup> generation CPUs also the **F2** key can be used.

For Atom CPUs also the **Esc** key can be used.

### Boot Selection Popup Menu

Press the **F11** key repeatedly directly after Power ON to display the Boot Selection Popup menu.

The popup menu allows selection of the boot device and the option to enter the BIOS setup program.

### BIOS Structure

The BIOS contains a menu bar, a left frame and a right frame.

The left frame displays all the options that can be configured in the selected menu.

The left frame uses following colors:

- Blue = Configurable options
- Greyed-out = Not configurable
- Inverse white = Selected

The right frame displays the key legend. Above the key legend is an area reserved for text messages.

These text messages explain the options and the possible impacts when you change the selected option in the left frame.

Use the →← keys to navigate between pages.

The menu bar gives access to following pages:

- **Main**
- **Advanced**
- **Chipset**
- **Security**
- **Boot**
- **Save & Exit**

## BIOS Navigation and Function Keys

---

The right part of the BIOS screens is divided in two parts.

Top part.

Provides additional information on selected screens or parameters.

Bottom part.

Provides information on Keys.

- **→←** : Select Screen  
Changed between different BIOS pages.
- **↑↓** : Select Item  
Changed between different parameters.
- **Enter: Select**  
Selects the parameter that has the focus and displays a submenu or the possibility to change the parameter.
- **+ / - : Change Option**  
Change settings. A numerical value will be increased or decreased. A boolean value will toggle.
- **F1: General Help**  
Displays help information.
- **F2: Previous Values**  
Changes all parameters to the values they had when entering the BIOS.
- **F9: Optimized Defaults**  
Changes all settings to the default values.
- **F10: Save & Exit**  
Saves all changes and exits the BIOS.
- **ESC: Exit**  
Go one level up. For parameters this is the previous level. For the main pages this exits the BIOS.

## BIOS Password & Write Protection

---

A BIOS password protects the BIOS setup program from unauthorized access. This ensures that users cannot change the system configuration without authorization. With an assigned BIOS password, the BIOS prompts the user for a password on a setup entry. If the password entered is wrong, the BIOS setup program will not launch.

The BIOS uses encryption for the password.

When a BIOS password is set the password is case sensitive with a minimum of 3 characters and a maximum of 20 characters. Setting no characters removes the BIOS password.

Once a BIOS password has been assigned, the BIOS activates the grayed out **BIOS Update and Write Protection** option. If this option is set to **enabled**, only authorized users (users with the correct password) can update the BIOS. With the BIOS password protection and the BIOS update and write protection, the system configuration is completely secured. If the BIOS is password protected, you cannot change the configuration of an end application without the correct password.



### Precautions for Safe Use

---

Remember the BIOS password. The BIOS is inaccessible without it.

---

To change an empty BIOS password:

1. Enter a new password at **Create New Password**  
Confirm with **Enter**
2. Enter the New Password a second time at **Confirm New Password**  
Confirm with **Enter**
3. Select **F10** to save the new password and exit the BIOS

The new password is set.

To change an existing BIOS password:

1. Enter the Current Password at **Enter Current Password**  
Confirm with **Enter**
2. Enter the New Password at **Create New Password**  
Confirm with **Enter**
3. Enter the New Password a second time at **Confirm New Password**  
Confirm with **Enter**
4. Select **F10** to save the new password and exit the BIOS

A new password is set.

To clear an existing BIOS password:

1. Enter the Current Password at **Enter Current Password**  
Confirm with **Enter**
  2. Leave the password field empty at **Create New Password**  
Confirm with **Enter**
  3. Confirm your change with **Yes** at the question **WARNING: Clear Old Password. Continue?**
  4. Select **F10** to save the new password and exit the BIOS
- The password is removed.

## A-1-2 BIOS for 4<sup>th</sup> generation CPUs

The BIOS settings for 4<sup>th</sup> generation CPUs.

Refer to the CPU information in *1-4 Product Configuration Panel PC* on page 1-5 for generation details.

The BIOS is divided in the pages Main, Advanced, Chipset, Boot, Security and Save & Exit.

### BIOS - Main

The main setup screen gives platform information about the BIOS, Board Information, Firmware Revision, MAC Addresses and information about the number of Boots and the Running Time.

Changeable BIOS Main parameters and their factory default values:

- **System Date**  
Use the **Enter** key to the next Date field.
- **System Time**  
Use the **Enter** key to the next Time field.

## BIOS - Advanced

This section provides Advanced BIOS information for 4<sup>th</sup> generation CPUs.

Changeable BIOS Advanced parameters and their factory default values:

Item		Default / Remark	
<b>Machine Control</b> *1		Disabled	
<b>Graphics</b>	Primary Graphics Device	Auto	
	Internal Graphics Device	Auto	
	IGD Pre-Allocated Graphics Memory	32M	
	IGD Total Graphics Memory	256M	
	Primary IGD Boot Display Device	Auto	
	Active LFP Configuration	<ul style="list-style-type: none"> <li>• eDP / for Industrial Panel PC</li> <li>• No Local Flat Panel / for Industrial Box PC</li> </ul>	
	Digital Display Interface 1	HDMI/DVI	
	Digital Display Interface 2	HDMI/DVI	
<b>Hardware Health Monitoring</b> *1	Start Temperature	50 C	
	Temperature Range	30 C	
	Minimum Fan Speed	30% / Fixed	
	Maximum Fan Speed	100%	
	Fan Always On At Minimum Speed	Disabled	
<b>PCI &amp; PCI Express</b>	PCI Latency Timer	32 PCI Bus Clocks	
	PERR # Generation	Disabled	
	SERR # Generation	Disabled	
	PIRQ Routing & IRQ Reservation	PIRQA,B,C,D,E,F,G,H	Auto
	PCI Express Settings	Relaxed Ordering	Disabled
		Extended Tag	Disabled
		No Snoop	Enabled
		Maximum Payload	Auto
		Maximum Read Request	Auto
		ASPM	Disabled
		Extended Synch	Disabled
		Link Training Retry	5
		Link Training Timeout (us)	100
Unpopulated Links		Disabled	
Restore PCIe Registers	Disabled		

Item		Default / Remark	
PCI & PCI Express	PCI Express Gen 2 Settings	Completion Timeout	Default
		ARI Forwarding	Disabled
		AtomicOp Requester Enable	Disabled
		AtomicOp Egress Blocking	Disabled
		IDO Request Enable	Disabled
		IDO Completion Enable	Disabled
		LTR Mechanism Enable	Disabled
		End-End TLP Prefix Blocking	Disabled
		Target Link Speed	Auto
		Clock Power Management	Disabled
		Compliance SOS	Disabled
		Hardware Autonomous Width	Enabled
		Hardware Autonomous Speed	Enabled
		PCI Express Gen3 Settings (for Port 0 and 1) *1	Run-time C7 Allowed
	Detect Non-compliant Device		Disabled
	Program PCIe ASPM after OpROM		Disabled
	PEG Sampler Calibrate		Disabled
	Swing Control		Full
	Peg Gen3 Equalization		Enabled
	- Gen3 EQ Phase 2		Enabled
	- PEG Gen3 Root Port Preset Value for each Lane. Lane 0...15		8
	- PEG Gen3 Endpoint Preset Value for each Lane. Lane 0...15		7
	- PEG Gen3 Endpoint Hint Value for each Lane. Lane 0...15		2
	- Gen3 Eq Preset Search		Enabled
	- Always Re-search Gen3 Eq Preset		Disabled
	- Preset Search Dwell Time		1000
	- Error Target		1
	PEG RxCEM Loopback Mode		Disabled
	PCIe Gen3 RxCTLEp Setting. PCIe Gen3 RxCTLEp 0...7	8	

Item		Default / Remark	
<b>PCI &amp; PCI Express</b>	GbE Channel 0	PCI Express Port 0	Enabled
		ASPM	Disabled
	GbE Channel 1	PCI Express Port 1	Enabled
		ASPM	Disabled
	PCI Express Port 0, 1 (x4 Gen3) *4	PEG1 Speed	Auto
		PEG1 ASPM	Disabled
		PEG1 De-emphasis Control	-3.5 dB
	PCI Express Port 2, 3, 4, 5 (x1 Gen2) *4	PCI Express Port x	Enabled
		ASPM	Disabled
		Hot Plug	Disabled
		PCIe Speed	Auto
		Detect Non-compliant Device	Disabled
<b>ACPI</b>	Hibernation Support		Disabled
	ACPI Sleep State		Suspend Disabled
	Lock Legacy Resources		Disabled
	S3 Video Repost		Disabled
	ACPI Low Power S0 Idle *3 *2		Disabled
	Native PCI Express Support		Enabled
	- Native ASPM		Disabled
	ACPI Debug		Disabled
	ACPI 5.0 CPPC Support		Disabled
	Active Trip Point *3 *2		71 C
	Automatic Critical Trip Point		Enabled
<b>RTC Wake</b>	Make System At Fixed Time		Disabled
<b>Trusted Computing</b>	Security Device Support		Enable
	TPM State		Enabled
	Pending operation		None

Item		Default / Remark	
<b>CPU</b>	CPU Information	Display of CPU parameters	
	Set Boot Freq Ratio	255	
	Hyper-Threading *2 *1	Enabled	
	Active Processor Cores	All	
	Limit CPUID Maximum	Disabled	
	Execute Disable Bit	Enabled	
	Intel Vitalization Technology	Enabled	
	Hardware Prefetcher	Enabled	
	Adjacent Cache Line Prefetch	Enabled	
	CPU AES *2 *1	Enabled	
	EIST	Enabled	
	- Turbo Mode *2 *1	Enabled	
	- Energy Performance *2 *1	Performance	
	P-State Reduction *3	Disabled	
	CPU C States	Disabled	
	TCC Activation Offset	0	
Intel TXT(LT) Support *2 *1	Disabled		
<b>SATA</b>	SATA Controller(s)	Enabled	
	SATA Mode Selection	AHCI	
	SATA Test Mode	Disabled	
	Aggressive LPM Support	Disabled	
	SATA Controller Speed	Default	
	Serial ATA Port 0, 1, 2, 3 *5	SATA Port	Enabled *5
		Hot Plug	Disabled
		External SATA	Disabled
SATA Device Type		Hard Disk Drive	
	Spin Up Device	Disabled	
<b>Memory Configuration</b>		Display of memory parameters	
<b>Intel (R) Rapid Start Technology</b>		Disabled	
<b>USB</b>	XHCI Mode	Enabled	
	Overcurrent Protection	Disabled	
	USB Ports Per-Port Disable Control	USB Ports Per-Port Disable Control	Enabled
		- USB Port 0...6	Enabled
		- USB 3.0 Port 0...1	Enabled
	Legacy USB Support	Enabled	
	External USB Controllers Support	Enabled	
	XHCI Hand-off	Enabled	
	EHCI Hand-off	Disabled	
	USB Mass Storage Driver Support	Enabled	
	USB Transfer Timeout	20 sec	
	Device Reset Timeout	20 sec	
Device Power-up Delay Selection	Auto		
Generic Ultra HS-COMBO	Auto		

Item		Default / Remark	
<b>SMART Settings</b>	Smart Self Test *6	Disabled	
<b>UEFI Network Stack</b>	UEFI Network Stack	Disabled	
<b>NVMe Configuration</b>		No NVME device found	
<b>Intel® Ethernet Connection I218-LM - Unique MAC Address</b>	NIC Configuration	Link Speed	Auto Negotiated
		Wake On LAN	Enabled
	Blink LEDs	0	

- \*1. Only for Panel PCs with a CPU type Intel® Core™ i7-4700EQ.
- \*2. Only for Panel PCs with a CPU type Intel® Core™ i5-4300U.
- \*3. Only for Panel PCs with a CPU type Intel® Celeron® 2980U.
- \*4. The active PCI Express Port number is related to the CPU type
  - Panel PCs with an Intel® Core™ i7-4700EQ CPU type use Port 0..5
  - Panel PCs with an Intel® Core™ i5-4300U CPU type use Port 2 and 3
  - Panel PCs with an Intel® Celeron® 2980U CPU type use Port 2 and 3
- \*5.
  - Panel PCs with an Intel® Celeron® 2980U CPU type only Port 0 and 1 are available
  - Panel PCs with an Intel® Core™ i5-4300U CPU type Port 1 is Disabled
  - Panel PCs with an Intel® Core™ i7-4700EQ CPU type Port 1 is Disabled. For Port 2: SATA Port = Enabled.
- \*6. Smart Self Test monitors the status of the HDD/SSD.  
Enable only when Smart Monitoring software is used.

## BIOS - Chipset

This section provides Chipset information for 4<sup>th</sup> generation CPUs.

Changeable BIOS Chipset parameters and their factory default values:

	Item	Default / Remark
<b>Platform Controller Hub (PCH)</b>	PCI Express Clock Gating	Disabled
	DMI Link ASPM PCH Side	Disabled
	DMI Link Extended Synch Control	Disabled
	Isolate SMBus Segments	During POST
	PCIe-USB Glitch W/A	Disabled
	USB Precondition	Disabled
	BTCG	Enabled
	HDA Controller	Auto
	HDA PME	Disabled
	PCH LAN Controller	Enabled
	Wake on LAN	Enabled
	Serial IRQ Mode	Continuous
	SB CRID	Disabled
	Port 80h Redirection	LPC Bus
	Subtractive Decode	Disabled
<b>Processor (Integrated Components)</b>	VT-d *1 *2	Enabled
	Audio Device (B0:D3:F0)	Enabled
	NB CRID	Disabled
	BDAT ACPI Table Support	Disabled

\*1. Only for Panel PCs with a CPU type Intel® Core™ i5-4300U.

\*2. Only for Panel PCs with a CPU type Intel® Core™ i7-4700EQ.

## BIOS - Boot

Provides Boot information and configuration settings.

Changeable BIOS Boot parameters and their factory default values:

Item		Default / Remark
<b>Quiet Boot</b>		Disabled
Setup Prompt Timeout		1
Bootup NumLock State		On
Battery Support		Auto (Battery Manager)
Power Loss Control *1		Remain Off
CSM & Option ROM Control	Launch CSM	Enabled
	Boot Option Filter	UEFI and Legacy
	PXE Option ROM Launch Policy	UEFI ROM Only
	Storage Option ROM Launch Policy	Legacy ROM Only
	Video Option ROM Launch Policy	Legacy ROM Only
	Other Option ROM Launch Policy	UEFI ROM Only
	Gate A20 Active	Upon Request
	Option ROM Messages	Force BIOS
Enter Setup If No Boot Device		No
Enable Popup Boot Menu		Yes
Boot Priority Selection		Type Based
Boot Option Sorting Method		Legacy First
Type Based Boot Priority	1st Boot Device	SATA 2 Drive *2
	2nd Boot Device	Disabled
	3rd Boot Device	Disabled
	4th Boot Device	Disabled
	5th Boot Device	Disabled
	6th Boot Device	Disabled
	7th Boot Device	Disabled
	8th Boot Device	Disabled
UEFI Fast Boot		Disabled

\*1. Power Loss Control settings are :

Remain OFF: The Industrial Panel PC will stay OFF when power is supplied to the power connector

Turn ON: The Industrial Panel PC will automatically start up when power is supplied to the power connector.

Last State: The Industrial Panel PC will start up or remain OFF when power is supplied based on the Industrial Panel PC state at the moment power was removed from the power connector.

\*2. For Panel PCs with a CPU type Intel® Celeron® 2980U: SATA 1 Drive

## BIOS - Security

Provides security information like BIOS Password and HDD information.

### WARNING

Security setting adjustments should only be performed by the engineer in charge that possesses a thorough understanding of the security settings. Selecting non-recommended security settings can put your system at risk.



Changeable BIOS Security parameters and their factory default values:

Item		Default / Remark	
<b>BIOS Password</b>		Empty	
<b>BIOS Lock</b>		Enabled	
<b>HDD Security Configuration</b>	Diskname	Display disk parameters	
<b>Secure Boot Menu</b>	Secure Boot	Disabled	
	Secure Boot Mode	Custom	
	Key Management	Default Key Provision	Disabled
		Platform Key (PK)	NOT INSTALLED
		Key Exchange Key (KEK)	NOT INSTALLED
		Authorized Signatures	NOT INSTALLED
		Forbidden Signatures	NOT INSTALLED
Authorized TimeStamps	NOT INSTALLED		

## BIOS - Save & Exit

Provides the possibility to leave the BIOS with or without saving changes.

Save & Exit Parameters:

- **Save Changes and Exit**  
Changed settings are saved and the Operating System starts with the changed settings.
- **Discard Changes and Exit**  
Changed settings are not saved and the Operating System starts with the unchanged settings.
- **Save Changes and Reset**  
Changed settings are saved and the Panel PC restarts using the changed settings.
- **Discard Changes and Reset**  
Changed settings are not saved and the Panel PC restarts with the unchanged settings.
- **Save Changes**  
Changed settings are saved and the BIOS setup stays open.
- **Discard Changes**  
Changed settings are reverted to their last saved values and the BIOS setup stays open.
- **Restore Defaults**  
Revert all BIOS settings to factory default.

## A-1-3 BIOS for 7<sup>th</sup> generation CPUs

The BIOS settings for 7<sup>th</sup> generation CPUs.

Refer to the CPU information in *1-4 Product Configuration Panel PC* on page 1-5 for generation details.

The BIOS is divided in the pages Main, Advanced, Chipset, Security, Boot and Save&Exit.

### BIOS - Main

---

The main setup screen gives platform information about the BIOS, Board Information, Firmware Revision, MAC Addresses and information about the number of Boots and the Running Time. Platform Information gives CPU and platform details.

Changeable BIOS Main parameters and their factory default values:

- **System Date**  
Use the **Enter** key to the next Date field.
- **System Time**  
Use the **Enter** key to the next Time field.

## BIOS - Advanced

This section provides Advanced BIOS information for 7<sup>th</sup> generation CPUs. Changeable BIOS Advanced parameters and their factory default values are grouped with the combination of your CPU type and the BIOS version.

CPU type	BIOS version	Refer to
Intel® Core™ i5-7300U	Up to version BV□□□008	<i>BIOS - Advanced BIOS up to version 008 on page A-16</i>
	Version BV□□□115 and higher	<i>BIOS - Advanced BIOS version 115 and higher on page A-22</i>
Intel® Celeron® 3965U	Up to version BU□□□008	<i>BIOS - Advanced BIOS up to version 008 on page A-16</i>
	Version BU□□□115 and higher	<i>BIOS - Advanced BIOS version 115 and higher on page A-22</i>
Intel® Core™ i7-7820EQ	All versions	<i>BIOS - Advanced for CPU Type Intel® Core™ i7-7820EQ on page A-24</i>

● **BIOS - Advanced BIOS up to version 008**

This section provides Advanced BIOS information for 7<sup>th</sup> generation CPUs:

- Intel® Core™ i5-7300U with a BIOS version up to BU□□□008
- Intel® Celeron® 3965U with a BIOS version up to BV□□□008

For all other CPU types or BIOS versions refer to *BIOS - Advanced* on page A-15 for details.

Changeable BIOS Advanced parameters and their factory default values:

	Item	Default / Remark
Intel RC ACPI Settings	PTID Support	Disabled
	PECI Access Method	Direct I/O
	Native PCI Express Support	Enabled
	Native ASPM	Disabled
	BDAT ACPI Table Support	Disabled
	Wake system from S5	Disabled
	ACPI Debug	Disabled
	Low Power S0 Idle Capability	Disabled
	Lpit Recidency Counter	SLP S0
	PCI Delay Optimization	Disabled
	ZpODD Support	Disabled

Item		Default / Remark	
CPU	SW Guard Extensions (SGX)	Software Controlled	
	Select Owner EPOCH input type	No Change in Owner EPOCHs	
	CPU Flex Ratio Override	Disabled	
	Hardware Prefetcher	Enabled	
	Adjacent Cache Line Prefetch	Enabled	
	Intel (VMX) Virtualization Technology	Enabled	
	PECI	Enabled	
	Active Processor Cores	All	
	Hyper-Threading *1	Enabled	
	BIST	Disabled	
	JTAG C10 Power	Disabled	
	AP threads Idle Manner	MWAIT Loop	
	AP threads Handoff Manner	MWAIT Loop	
	AES	Enabled	
	MachineCheck	Enabled	
	MonitorMWait	Enabled	
	Intel Trusted Execution Technology *1	Disabled	
	Reset AUX Content *1	No	
	Flash Wear Out Protection	Disabled	
	Debug Interface	Disabled	
	Debug Interface Lock	Enabled	
	Processor trace memory allocation	Disabled	
	CPU SMM Enhance-ment	SMM Code Access Check	Enabled
		SMM Use Delay Indication	Enabled
		SMM Use Block Indication	Enabled
	FCLK Frequency for Early Power On	Normal (800 Mhz)	
	Three Strike Counter	Enabled	
Voltage Optimization	Auto		

Item		Default / Remark	
Power & Performance	CPU - Power Management Control	Boot performance mode	Max Non-Turbo Performance
		Intel ® SpeedStep™	Enabled
		Race To Halt (RTH)	Enabled
		Intel ® Speed Shift Technology	Enabled
		HDC Control	Enabled
		Turbo Mode *1	Enabled
	CPU - Power Management Control /View/Configure Turbo Options		
		Energy Efficient P-state	Enabled
		Package Power Limit MSR Lock	Disabled
		1-Core Ratio Limit Override	CPU specific *3
		2-Core Ratio Limit Override	CPU specific *3
		Energy Efficient Turbo	Enabled
	CPU - Power Management Control /Config TDP Configurations		
		Configurable TDP Boot Mode	Nominal
		Configurable TDP Lock	Enabled
	CPU - Power Management Control / CPU VR Settings *2		
		PSYS Slope	0
		PSYS Offset	0
		PSYS PMax Power	0
		Acoustic Noise Settings	Acoustic Noise Mitigation = Disabled
		System Agent VR Settings	VR Config Enable = Disabled
		Core/IA VR Settings	VR Config Enable = Disabled
		GT-Sliced VR Settings	VR Config Enable = Disabled
		VR Mailbox Command options	0
		Intersil VR Command	Disabled
		CPU - Power Management Control	Platform PL1 Enable
	Platform PL2 Enable		Disabled
	Power Limit 4 Override		Disabled
	C states		Disabled
	Thermal Monitor		Enabled
	Interrupt Redirection Mode Selection		PAIR with Fixed Priority
	Timed MWAIT		Disabled
	Custom P-state Table		Number of P states = 0
EC Turbo Control Mode	Disabled		
Energy Performance Gain	Disabled		
Power Limit 3 Settings	Power Limit 3 Override = Disabled		
CPU Lock Configuration	CFG Lock = Enabled		
	Overclocking Lock = Enabled		

Item		Default / Remark		
Power & Performance	GT - Power Management Control	Maximum GT frequency Default Max Frequency		
PCH-FW Configuration	Comms Hub Support		Disabled	
	JHI Support		Disabled	
	Core Bios Done Message		Enabled	
	Firmware Update Configuration	Me FW Image Re-Flash	Disabled	
	PTT Configuration	TPM Device Selection	dTPM	
	ME Debug Configuration	HECI Timeouts		Enabled
		Force ME DID Init Status		Disabled
		CPU Replaced Polling Disable		Disabled
		ME DID Message		Enabled
		HECI Retry Disable		Disabled
		HECI Message check Disable		Disabled
		MBP HOB Skip		Disabled
		HECI2 Interface Communication		Disabled
		KT Device		Enabled
		IDER Device		Enabled
End Of Post Message		Send in DXE		
DOI3 Setting for HECI Disable		Disabled		
Thermal Configuration	CPU Thermal Configuration	DTS SMM	Disabled	
		Tcc Activation Offset	CPU specific <sup>*4</sup>	
		Tcc Offset Time Window	Disabled	
		Tcc Offset Clamp Enable	Disabled	
		Tcc Offset Lock Enable	Disabled	
		Bi-directional PROCHOT#	Disabled	
		Disable VR Thermal Alert	Disabled	
		PROCHOT Response	Disabled	
		PROCHOT Lock	Enabled	
		ACPI T-States	Disabled	
		PECI Reset	Disabled	
		PECI C10 Reset	Disabled	
		Platform Thermal Configuration	PCH Thermal Device	Enabled in PCI mode
	PCH Temp Read		Enabled	
	CPU Energy Read		Enabled	
	CPU Temp Read		Enabled	
	Alert Enable Lock		Disabled	
	DPTF Configuration	DPTF	Disabled	

	Item	Default / Remark
Platform Settings	UCSI Retry Workaround	Disabled
	Firmware Configuration	Test
	PS2 Keyboard and Mouse	Enabled
	Pmic Vcc IO Level	Disabled
	Pmic Vddq Level	Disabled
	SLP_SO# VM	Disabled
	Power Sharing Manager	Disabled
	Wireless device	Disabled
	Enable Wireless Charge Support	Disabled
	Enable FFU support	Disabled
	HID Event Filter Driver	Disabled
	Alternate Mode Synch Delay	0
Intel ICC	ICC/OC Watchdog Timer	Disabled
	ICC PLL Shutdown	Enabled
Watchdog	POST Watchdog	Disabled
	Runtime Watchdog	Disabled
Trusted Computing	Security Device Support	Enable
	SHA-1 PCR Bank	Enabled
	SHA256 PCR Bank	Enabled
	Pending operation	None
	Platform Hierarchy	Enabled
	Storage Hierarchy	Enabled
	Endorsement Hierarchy	Enabled
	TPM2.0 UEFI Spec Version	TCG_2
	Physical Presence Spec Version	1.3
	Device Select	Auto
ACPI	Enable ACPI Auto Configuration	Disabled
	Hibernation Support	Disabled
	ACPI Sleep State	Suspend Disabled
	Lock Legacy Resources	Disabled
	S3 Video Repost	Disabled
	Automatic Critical Trip Point	Enabled
	Lid Button Support	Disabled
	Sleep Button Support	Disabled
SMART Settings	SMART Self Test	Disabled
Acoustic Management	Acoustic Management Configuration	Disabled

Item		Default / Remark	
PCI Configuration	PCI Latency Timer	32 PCI Bus Clocks	
	PCI-X Latency Timer	64 PCI Bus Clocks	
	VGA Palette Snoop	Disabled	
	PERR# Generation	Disabled	
	SERR# Generation	Disabled	
	Above 4G Decoding	Disabled	
	PCI Hot-Plug Settings	BIOS Hot-Plug Support	Enabled
		PCI Buses Padding	1
		I/O Resources Padding	4 K
MMIO 32 bit Resources Padding		16 M	
PFMMIO 32 bit Resources Padding		16 M	
UEFI Network Stack	UEFI Network Stack	Disabled	
CSM & Option ROM Control	CSM Support	Enabled	
	Gate A20 Active	Upon Request	
	Option ROM Messages	Force BIOS	
	INT19 Trap Response	Immediate	
	Boot Option Filter	UEFI and Legacy	
	PXE Option ROM Launch Policy	UEFI ROM Only	
	Storage Option ROM Launch Policy	UEFI ROM Only	
	Video Option ROM Launch Policy	Legacy ROM Only	
	Other Option ROM Launch Policy	UEFI ROM Only	
SDIO Configuration	SD Card or COMx GPIO	COMx GPIO	
	UART0 Controller	Disabled	
	SDIO Access Mode	Auto	
USB	Overcurrent Protection	Disabled	
	Legacy USB Support	Enabled	
	xHCI Hand-off	Enabled	
	USB Mass Storage Driver Support	Enabled	
	USB Transfer Timeout	20 sec	
	Device Reset Timeout	20 sec	
	Device Power-up Delay Selection	Auto	
	Generic Ultra HS-COMBO	Auto	
Diagnostic Settings	Relay Interface	Disabled	
	BC Diagnostic Console Interface	Disabled	

- \*1. Only for CPU type Intel® Core™ i5-7300U
- \*2. Only for CPU type Intel® Celeron® 3965U
- \*3. For CPU type Intel® Celeron® 3965U = 22  
For CPU type Intel® Core™ i5-7300U = 35
- \*4. For CPU type Intel® Celeron® 3965U = 0  
For CPU type Intel® Core™ i5-7300U = 5

● **BIOS - Advanced BIOS version 115 and higher**

This section provides Advanced BIOS information for 7<sup>th</sup> generation CPUs:

- Intel® Core™ i5-7300U with a BIOS version BU□□□115 and higher
- Intel® Celeron® 3965U with a BIOS version BV□□□115 and higher

For all other CPU types or BIOS versions refer to *BIOS - Advanced* on page A-15 for details.

Changeable BIOS Advanced parameters and their factory default values:

Item		Default / Remark	
CPU	SW Guard Extensions (SGX)	Software Controlled	
	Select Owner EPOCH input type	No Change in Owner EPOCHs	
	Hardware Prefetcher	Enabled	
	Adjacent Cache Line Prefetch	Enabled	
	Intel (VMX) Virtualization Technology	Enabled	
	Active Processor Cores	All	
	Hyper-Threading* <sup>2</sup>	Enabled	
	BIST	Disabled	
	AP threads Idle Manner	MWAIT Loop	
	AP threads Handoff Manner	MWAIT Loop	
	AES	Enabled	
	MachineCheck	Enabled	
MonitorMWait	Enabled		
Power & Performance	CPU - Power Management Control	Boot performance mode	Max Non-Turbo Performance
		Intel® SpeedStep™	Enabled
		Race To Halt (RTH)	Enabled
		Intel® Speed Shift Technology	Enabled
		Turbo Mode* <sup>1</sup>	Enabled
		C states	Disabled
	Timed MWAIT	Disabled	
GT - Power Management Control	Maximum GT frequency	Default Max Frequency	
Trusted Computing	Security Device Support		Enable
	SHA-1 PCR Bank		Enabled
	SHA256 PCR Bank		Enabled
	Pending operation		None
	Platform Hierarchy		Enabled
	Storage Hierarchy		Enabled
	Endorsement Hierarchy		Enabled
	TPM2.0 UEFI Spec Version		TCG_2
	Physical Presence Spec Version		1.3
	Device Select		Auto
RTC Wake Settings	RTC Wake Mode	Disabled	
AMI Graphic Output Protocol Policy	Output Select* <sup>2</sup>	EDP1	
CSM & Option ROM Control	CSM Support* <sup>3</sup>	Disabled	

Item		Default / Remark
USB	Overcurrent Protection	Disabled
	Legacy USB Support	Enabled
	xHCI Hand-off	Enabled
	USB Mass Storage Driver Support	Enabled
	USB Transfer Timeout	20 sec
	Device Reset Timeout	20 sec
	Device Power-up Delay Selection	Auto
	Generic Ultra HS-COMBO	Auto

- \*1. Only for CPU type Intel® Celeron® 3965U
- \*2. Only for CPU type Intel® Core™ i5-7300U
- \*3. For IPC's with Windows 10 IoT Enterprise 2016 LTSB - 64 bit (OS option 3) CSM Support = Enabled

● **BIOS - Advanced for CPU Type Intel® Core™ i7-7820EQ**

This section provides Advanced BIOS information for the 7<sup>th</sup> generation CPU type Intel® Core™ i7-7820EQ.

For all other CPU types refer to *BIOS - Advanced* on page A-15 for details.

Changeable BIOS Advanced parameters and their factory default values:

Item		Default / Remark	
CPU	SW Guard Extensions (SGX)	Software Controlled	
	Select Owner EPOCH input type	No Change in Owner EPOCHs	
	Hardware Prefetcher	Enabled	
	Adjacent Cache Line Prefetch	Enabled	
	Intel (VMX) Virtualization Technology	Enabled	
	Active Processor Cores	All	
	Hyper-Threading	Enabled	
	BIST	Disabled	
	AP threads Idle Manner	MWAIT Loop	
	AP threads Handoff Manner	MWAIT Loop	
	AES	Enabled	
	MachineCheck	Enabled	
	MonitorMWait	Enabled	
Power & Performance	CPU - Power Management Control	Boot performance mode	Max Non-Turbo Performance
		Intel® SpeedStep™	Enabled
		Race To Halt (RTH)	Enabled
		Intel® Speed Shift Technology	Enabled
		Turbo Mode	Enabled
		C states	Disabled
	Timed MWAIT	Disabled	
GT - Power Management Control	Maximum GT frequency	Default Max Frequency	
Graphics	Digital Display Interface 1	Auto Selection	
	Digital Display Interface 2	Auto Selection	
	VGA Port	Enabled	
	DisplayPort Spread Spectrum Clock	Disabled	
Hardware Health Monitoring	Fan Control Temperature	CPU Temperature	
	Lower Temperature Threshold	50 C	
	Upper Temperature Threshold	80 C	
	Minimum Fan Speed	Fan Off	
	Lower Temperature Fan Speed	30%	
	Upper Temperature Fan Speed	100%	
	Maximum Fan Speed	100%	

Item		Default / Remark
Trusted Computing	Security Device Support	Enable
	SHA-1 PCR Bank	Enabled
	SHA256 PCR Bank	Enabled
	Pending operation	None
	Platform Hierarchy	Enabled
	Storage Hierarchy	Enabled
	Endorsement Hierarchy	Enabled
	TPM2.0 UEFI Spec Version	TCG_2
	Physical Presence Spec Version	1.3
	Device Select	Auto
RTC Wake Settings	RTC Wake Mode	Disabled
ACPI	Enable ACPI Auto Configuration	Disabled
	Hibernation Support	Disabled
	ACPI Sleep State	Suspend Disabled
	Lock Legacy Resources	Disabled
	S3 Video Repost	Disabled
	Automatic Critical Trip Point	Enabled
AMI Graphic Output Protocol Policy	Output Select	EDP1
	Brightness Setting	255
	BIST Enable	Disabled
PCI Configuration	PCI Latency Timer	32 PCI Bus Clocks
	PERR# Generation	Disabled
	SERR# Generation	Disabled
	Above 4G Decoding	Disabled
UEFI Network Stack	UEFI Network Stack	Disabled
CSM & Option ROM Control	CSM Support	Disabled
NVMe Configuration	–	–
USB	Overcurrent Protection	Disabled
	Legacy USB Support	Enabled
	xHCI Hand-off	Enabled
	USB Mass Storage Driver Support	Enabled
	USB Transfer Timeout	20 sec
	Device Reset Timeout	20 sec
	Device Power-up Delay Selection	Auto
	Generic Ultra HS-COMBO	Auto

## BIOS - Chipset

This section provides Chipset information for 7<sup>th</sup> generation CPUs.

Changeable Chipset parameters and their factory default values are grouped with the combination of your CPU type and the BIOS version.

CPU type	BIOS version	Refer to
Intel® Core™ i5-7300U	Up to version BV□□□008	<ul style="list-style-type: none"> <li>• <i>BIOS - Chipset BIOS up to version 008</i> on page A-27</li> <li>• <i>BIOS - Chipset Details</i> on page A-32</li> </ul>
	Version BV□□□115 and higher	<i>BIOS - Chipset BIOS version 115 and higher</i> on page A-34
Intel® Celeron® 3965U	Up to version BU□□□008	<ul style="list-style-type: none"> <li>• <i>BIOS - Chipset BIOS up to version 008</i> on page A-27</li> <li>• <i>BIOS - Chipset Details</i> on page A-32</li> </ul>
	Version BU□□□115 and higher	<i>BIOS - Chipset BIOS version 115 and higher</i> on page A-34
Intel® Core™ i7-7820EQ	All versions	<i>BIOS - Chipset for CPU Type Intel® Core™ i7-7820EQ</i> on page A-36

● **BIOS - Chipset BIOS up to version 008**

This section provides Chipset information for 7<sup>th</sup> generation CPUs:

- Intel® Core™ i5-7300U with a BIOS version up to BU□□□008
- Intel® Celeron® 3965U with a BIOS version up to BV□□□008

For all other CPU types or BIOS versions refer to *BIOS - Chipset* on page A-26 for details.

Changeable BIOS Chipset parameters and their factory default values:

Item		Default / Remark
Processor (Integrated Components)	Memory Configuration / Memory Thermal Configuration	Refer to <i>Memory Thermal Configuration</i> on page A-32 for details.
	Memory Configuration / Memory Training Algorithms	
	Early Command Training	Disabled
	SenseAmp Offset Training	Enabled
	Early ReadMPR Timing Centering 2D	Enabled
	Read MPR Training	Enabled
	Receive Enable Training	Enabled
	Jedec Write Leveling	Enabled
	Early Write Time Centering 2D	Enabled
	Early Write Drive Strength / Equalization	Enabled
	Early Read Time Centering 2D	Enabled
	Write Timing Centering 1D	Enabled
	Write Voltage Centering 1D	Enabled
	Read Timing Centering 1D	Enabled
	Dimm ODT Training*	Enabled
	Max RTT_WR	ODT Off
	DIMM RON Training*	Enabled
	Write Drive Strength/Equalization 2D*	Disabled
	Write Slew Rate Training*	Enabled
	Read ODT Training*	Enabled
	Read Equalization Training*	Enabled
Read Amplifier Training*	Enabled	
Write Timing Centering 2D	Enabled	
Read Timing Centering 2D	Enabled	
Command Voltage Centering	Enabled	

Item		Default / Remark	
<b>Processor (Integrated Components)</b>	Memory Configuration / Memory Training Algorithms		
	Write Voltage Centering 2D	Enabled	
	Read Voltage Centering 2D	Enabled	
	Late Command Training	Enabled	
	Round Trip Latency	Enabled	
	Turn Around Timing Training	Enabled	
	Rank Margin Tool	Disabled	
	Memory test	Disabled	
	DIMM SPD Alias Test	Enabled	
	Receive Enable Centering 1D	Enabled	
	Retrain Margin Check	Enabled	
	Write Drive Strength Up/Dn independently	Disabled	
	CMD Slew Rate Training	Enabled	
	CMD Drive Strength / Tx Equalization	Enabled	
	CMD Normalization	Enabled	
	Memory Configuration	MRC ULT Safe Config	Disabled
		Maximum Memory Frequency	2133
		HOB Buffer Size	Auto
		Max TOLUD	Dynamic
		SA GV	Fixed High
		Retrain on Fast Fail	Enabled
		Command Tristate	Enabled
		Enable RH Prevention	Enabled
		Row Hammer Solution	Hardware RHP
		RH Activation Probability	1/2 <sup>11</sup>
		Exit On Failure (MRC)	Enabled
		MC Lock	Enabled
		Probeless Trace	Disabled
		Enable/Disable IED (Intel Enhanced Debug)	Disabled
		Ch Hash Support	Enabled
		Ch Hash Mask	0
		Ch Hash Interleaved Bit	BIT8
		VC1 Read Metering	Enabled
		VC1 RdMeter Time Window	800
	VC1 RdMeter Threshold	280	
	Strong Weak Leaker	7	
	Memory Scrambler	Enabled	
	Force ColdReset	Disabled	
	Channel A DIMM Control	Enable both DIMMs	
	Channel B DIMM Control	Enable both DIMMs	

Item		Default / Remark	
<b>Processor (Integrated Components)</b>	Memory Configuration	Force Single Rank	Disabled
		Memory Remap	Enabled
		Time Measure	Disabled
		DLL Weak Lock Support	Enabled
		Pwr Down Idle Timer	0
		Mrc Fast Boot	Enabled
		Lpddr Mem WL Set	Set B
		EV Loader	Disabled
		EV Loader Delay	Enabled
	Graphics Configura- tion	Graphics Turbo IMON Current	31
		Primary Display	Auto
		Select PCIE Card	Auto
		External Gfx Card Primary Display Configuration	Primary PEG = Auto Primary PCIE = Auto
		Internal Graphics Device	Auto
		GTT Size	8MB
		Aperture Size	256MB
		IGD Pre-Allocated Graphics Mem- ory	32M
		IGD Total Graphics Memory	256M
		Gfx Low Power Mode	Disabled
		VDD Enable	Enabled
		PM support	Disabled
		PAVP Enable	Enabled
		Cdynmax Clamping Enable	Enabled
		Cd Clock Frequency	675 Mhz
	GOP Config Driver	Enabled	
	IUER Button Enable	Disabled	
	Intel ® Ultrabook Event Support	IUER Slate Enable = Disabled IUER Dock Enable = Disabled	
	DMI/OPI Configura- tion	DMI Vc1 Control	Disabled
		DMI Vcm Control	Enabled
	Stop Grant Configuration	Auto	
	VT-d	Enabled	
	CHAP Device	Disabled	
	Thermal Device	Disabled	
GMM Device	Enabled		
CRID Support	Disabled		
Above 4GB MMI BIOS assignment	Disabled		
X2APIC Opt Out	Disabled		
eDRAM Mode	eDRAM HW Mode		

Item		Default / Remark	
Platform Controller Hub (PCH)	Isolate SMBus Segments	Always	
	PCI Express Configuration	PCI Express Clock Gating	Disabled
		Legacy IO Low Latency	Disabled
		DMI Link ASPM PCH Side	Disabled
		Port8xh Decode	Disabled
		Peer Memory Write Enable	Disabled
		Compliance Test Mode	Disabled
		PCIe-USB Glitch W/A	Disabled
		PCIe function swap	Disabled
		PCI Express Gen3 Eq Lanes	Every Cm = 6 Every Cp = 2 Override SW EQ Settings = Disabled
		PCI Express Port 0	Refer to <i>PCI Express Port</i> on page A-33 for details.
		PCI Express Port 2	
		PCI Express Port 3	
	PCI Express Port 4		
	PCI Express Port 6		
	PCI Express Port 6		
	SATA And RST Configuration	SATA Controller(s)	Enabled
		SATA Mode Selection	AHCI
		SATA Test Mode	Disabled
		Software Feature Mask Configuration	HDD Unlock = Enabled LED Locate = Enabled
		Aggressive LPM Support	Disabled
		SATA Controller Speed	Default
		Serial ATA Port 0	
		SATA Port	Enabled *1
		Hot Plug	Disabled
		Spin Up Device	Disabled
		SATA Device Type	Hard Disk Drive
		Topology	Unknown
		SATA Port 0 DevSlp	Disabled
		DITO Configuration	Disabled
		Serial ATA Port 1	
		SATA Port	Enabled *1
		Hot Plug	Disabled
Spin Up Device		Disabled	
SATA Device Type		Hard Disk Drive	
Topology		Unknown	
SATA Port 1 DevSlp		Disabled	
DITO Configuration		Disabled	
Serial ATA Port 2			
SATA Port		Enabled *1	

Item		Default / Remark	
Platform Controller Hub (PCH)	SATA And RST Configuration	Hot Plug	Disabled
		Spin Up Device	Disabled
		SATA Device Type	Hard Disk Drive
		Topology	Unknown
		SATA Port 2 DevSlp	Disabled
		DITO Configuration	Disabled
	USB Configuration	XHCI Disable Compliance Mode	False
		xDCI Support	Disabled
		USB Port Disable Override	Disabled
	TraceHub Configuration menu	TraceHub Enable Mode	Disable
		MemRegion 0 Buffer Size	1MB
		MemRegion 1 Buffer Size	1MB
	DCI enable (HDCIEN)		Disabled
	PCH LAN Controller		Enabled
	DeepSx Power Policies		Disabled
	LAN Wake From DeepSx		Enabled
	Wake on LAN Enable		Enabled
	SLP_LAN# Low on DC Power		Enabled
	K1 off		Enabled
	Wake on WLAN and BT Enable		Disabled
	Disable DSX ACPRESENT Pulldown		Disabled
	Serial IRQ Mode		Continuous
	Port 61h Bit-4 Emulation		Enabled
	Port 80h Redirection		LPC Bus
	Enhance Port 80h LPC Decoding		Disabled
	Compatible Revision ID		Disabled
	PCH Cross Throttling		Enabled
	Disable Energy Reporting		FALSE
	Enable TCO Timer		Disabled
	Pcie P11 SSC		Auto
	IOAPIC 24-119 Entries		Enabled
	Unlock PCH P2SB		Disabled
Flash Protection Range Registers (FPRR)		Disabled	
SPD Write Disable		TRUE	
ChipsetInit HECI Message		Enabled	
Bypass ChipsetInit sync reset		Disabled	

\*1. Disabled when a storage device is not present on SATA port.

## ● BIOS - Chipset Details

This section provides BIOS Chipset details for:

- 6<sup>th</sup> generation CPUs
- 7<sup>th</sup> generation CPUs with a BIOS version upto version 008

For all other CPU types or BIOS versions refer to *BIOS - Chipset* on page A-26 for details.

### ■ Memory Thermal Configuration

Provides BIOS Chipset details for the submenu Processor / Memory Configuration / Memory Thermal Configuration /.

Changeable BIOS Memory Thermal Configuration parameters and their factory default values:

Item		Default / Remark
Memory Power and Thermal Throttling	DDR PowerDown and idle counter	BIOS
	For LPDDR Only: DDR PowerDown and idle counter	BIOS
	REFRESH_2X_MODE	Disabled
	LPDDR Thermal Sensor	Enabled
	SelfRefresh Enable	Enabled
	SelfRefresh IdleTimer	512
	Throttler CKEMin Defeature	Disabled
	Throttler CKEMin Timer	48
	For LPDDR Only: Throttler CKEMin Defeature *1	Enabled
	For LPDDR Only: Throttler CKEMin Timer *1	64
DRAM Power Meter	Use user provided power weights, scale factor, and channel power floor values	Disabled
Memory Thermal Reporting	Lock Thermal Management Registers	Enabled
	Extern Therm Status	Disabled
	Closed Loop Therm Manage	Disabled
	Open Loop Therm Manage	Disabled
	Thermal Threshold Settings	All settings = 255
Memory RAPL	Thermal Throttle Budget Settings	All settings = 255
	RAPL PL Lock	Disabled
	RAPL PL 1 enable	Disabled
	RAPL PL 1 Power	0
	RAPL PL 1 WindowX	0
	RAPL PL 1 WindowY	0
	RAPL PL 2 enable	Disabled
	RAPL PL 2 Power	222
RAPL PL 2 WindowX	1	
RAPL PL 2 WindowY	10	
Memory Thermal Management		Disabled

\*1. Available for 7<sup>th</sup> generation CPUs. Not available for 6<sup>th</sup> generation CPUs.

## ■ PCI Express Port

Provides BIOS Chipset details for the submenu Platform Controller Hub / PCI Express Configuration / PCI Express Port.

Changeable BIOS PCI Express Port parameters and their factory default values:

Item	Default / Remark	
PCI Express Port	Enabled	
Topology	CPU specific *1	
ASPM	Disabled	
Gen 3 Eq Phase3 Method	Software Search	
UPTP	5	
DPTP	7	
ACS	Enabled	
URR	Disabled	
FER	Disabled	
NFER	Disabled	
CER	Disabled	
CTO	Disabled	
SEFE	Disabled	
SENF	Disabled	
SECE	Disabled	
PME SCI	Enabled	
Hot Plug	Disabled	
Advanced Error Reporting	Enabled	
PCIe Speed	Auto	
Transmitter Half Swing	Disabled	
Detect Timeout	0	
PCH PCIE□ LTR *2	Enabled	
Snoop Latency Override	Auto	
Non Snoop Latency Override	Auto	
Force LTR Override	Disabled	
PCIE□ LTR Lock *2	Disabled	
Extra options	Detect Non-Compliance Device	Disabled
	Prefetchable Memory	10
	Reserved Memory Alignment	1
	Prefetchable Memory Alignment	1

\*1. CPU specific:

- For 7<sup>th</sup> generation CPUs: Port 0, 4 = Unknown. Port 2, 3, 6 = x1.
- For 6<sup>th</sup> generation CPUs: Port 0, 1, 2, 5, 6, 7 = Unknown. Port 3, 4 = x1.

\*2. The default does not change but the PCIE number is port specific.

- For 7<sup>th</sup> generation CPUs:  
Port 0: PCIE1. Port 2: PCIE3. Port 3: PCIE4. Port 4: PCIE5. Port 6: PCIE9.
- For 6<sup>th</sup> generation CPUs:  
Port 0: PCIE5. Port 1: PCIE6. Port 2: PCIE7. Port 3: PCIE8. Port 4: PCIE9. Port 5: PCIE10. Port 6: PCIE11. Port 7: PCIE12.

● **BIOS - Chipset BIOS version 115 and higher**

This section provides Chipset BIOS information for 7<sup>th</sup> generation CPUs:

- Intel® Core™ i5-7300U with a BIOS version BU□□□115 and higher
- Intel® Celeron® 3965U with a BIOS version BV□□□115 and higher

For all other CPU types or BIOS versions refer to *BIOS - Chipset* on page A-26 for details.

Changeable BIOS Chipset parameters and their factory default values:

Item		Default / Remark	
<b>Processor (Integrated Components)</b>	Memory Configuration	Max TOLUD	Dynamic
		Memory Remap	Enabled
	Graphics Configura- tion	Primary Display	Auto
		Select PCIE Card	Auto
		Internal Graphics Device	Auto
		GTT Size	8MB
		Aperture Size	256MB
		IGD Pre-Allocated Graphics Mem- ory	32M
		IGD Total Graphics Memory	256M
	GOP Config Driver	Enabled	
	VT-d	Enabled	
Above 4GB MMIO BIOS assignment	Disabled		

Item		Default / Remark	
Platform Controller Hub (PCH)	Isolate SMBus Segments	Always	
	PCI Express Configuration / PCI Express x2 Slot	PCI Express Port	Enabled
		ASPM	Disabled
		Hot Plug	Disabled
		PCIe Speed	Auto
		Extra options	Detect Non-Compliance Device = Disabled
			Prefetchable Memory = 10
			Reserved Memory Alignment = 1
			Prefetchable Memory Alignment = 1
	PCI Express Configuration / Ethernet Port 2, 3	PCI Express Port	Enabled
		ASPM	Disabled
	PCI Express Configuration / PCI Express Port 4,6	PCI Express Port	Enabled
		ASPM	Disabled
		Hot Plug	Disabled
		PCIe Speed	Auto
		Extra options	Detect Non-Compliance Device = Disabled
			Prefetchable Memory = 10
			Reserved Memory Alignment = 1
			Prefetchable Memory Alignment = 1
	SATA And RST Configuration	SATA Controller(s)	Enabled
		SATA Mode Selection	AHCI
		Software Feature Mask Configuration	HDD Unlock = Enabled
			LED Locate = Enabled
		SATA Controller Speed	Default
		SATA Port 0	Enabled *1
		SATA Port 1	Enabled *1
		SATA Device Type	Solid State Drive
		SATA Port 2	Enabled *1
		SATA Device Type	Hard Disk Drive
	USB Configuration	USB Port Disable Override	Disabled
	PCH LAN Controller	Enabled	
LAN Wake From DeepSx	Enabled		
Wake on LAN Enable	Enabled		
Serial IRQ Mode	Continuous		
PCIe Spread Spectrum Clocking	Auto		
IOAPIC 24-119 Entries	Enabled		

\*1. Disabled when a storage device is not present on the SATA port.

● **BIOS - Chipset for CPU Type Intel® Core™ i7-7820EQ**

This section provides Chipset information for the 7<sup>th</sup> generation CPU type Intel® Core™ i7-7820EQ. For all other CPU types refer to *BIOS - Chipset* on page A-26 for details.

Changeable BIOS Chipset parameters and their factory default values:

Item		Default / Remark	
<b>Processor (Integrated Components)</b>	Memory Configuration	Max TOLUD	Dynamic
		Memory Remap	Enabled
	Graphics Configura- tion	Primary Display	Auto
		Select PCIE Card	Auto
		Internal Graphics Device	Auto
		GTT Size	8MB
		Aperture Size	256MB
		IGD Pre-Allocated Graphics Mem- ory	32M
		IGD Total Graphics Memory	256M
		GOP Config Driver	Enabled
	VT-d	Enabled	
	GMM Device	Enabled	
	Above 4GB MMIO BIOS assignment	Disabled	

Item		Default / Remark	
<b>Platform Controller Hub (PCH)</b>	Isolate SMBus Segments	During POST	
	PCI Express Configuration / PCI Express Port 0, 4, 6, 7	PCI Express Port	Enabled
		ASPM	Disabled
		Hot Plug	Disabled
		PCIe Speed	Auto
		Extra options	Detect Non-Compliance Device = Disabled
			Prefetchable Memory = 10
			Reserved Memory Alignment = 1
	PCI Express Configuration / Ethernet Port 2, 3	PCI Express Port	Enabled
		ASPM	Disabled
	SATA And RST Configuration	SATA Controller(s)	Enabled
		SATA Mode Selection	AHCI
		Software Feature Mask Configuration	HDD Unlock = Enabled
			LED Locate = Enabled
		SATA Controller Speed	Default
		SATA Port 0	Enabled *1
		SATA Port 1	Enabled *1
		SATA Port 2	Enabled *1
		SATA Device Type	Hard Disk Drive
		SATA Port 3	Enabled *1
	SATA Device Type	Hard Disk Drive	
	USB Configuration	USB Port Disable Override	Disabled
	PCH LAN Controller		Enabled
LAN Wake From DeepSx		Enabled	
Wake on LAN Enable		Enabled	
Serial IRQ Mode		Continuous	
PCIe Spread Spectrum Clocking		Auto	

\*1. Disabled when a storage device is not present on the SATA port.

## BIOS - Security

Provides security information like BIOS Password and HDD information.

WARNING

Security setting adjustments should only be performed by the engineer in charge that possesses a thorough understanding of the security settings. Selecting non-recommended security settings can put your system at risk.



Changeable BIOS Security parameters and their factory default values:

Item		Default / Remark	
<b>BIOS Password</b>		Empty	
<b>BIOS Lock</b>		Enabled	
<b>HDD Security Configuration</b>	Diskname	Display disk parameters *1	
	<b>Secure Boot Menu</b>		
	Secure Boot	Disabled	
	Secure Boot Customization	CPU specific *2	
	Key Management *3	Factory Key Provision	Disabled
		Secure Boot variable	Display variable details

\*1. Only when a storage device is installed. The default password for a storage device is empty.

\*2. For:

- Intel® Core™ i7-7820EQ CPU Secure Boot Customization = Standard
- other CPU types with a BIOS version up to B□□□□008 CPU Secure Boot Customization = Custom
- other CPU types with a BIOS version B□□□□115 and higher CPU Secure Boot Customization = Standard

\*3. Only applicable for:

- Intel® Celeron® 3965U with a BIOS version up to BU□□□008
- Intel® Core™ i5-7300U with a BIOS version up to BV□□□008

## BIOS - Boot

This section provides Boot information for 7<sup>th</sup> generation CPUs.

Changeable Boot parameters and their factory default values are grouped with the combination of your CPU type and the BIOS version.

CPU type	BIOS version	Refer to
Intel® Core™ i5-7300U	Up to version BV□□□008	<i>BIOS - Boot BIOS up to version 008 on page A-40</i>
	Version BV□□□115 and higher	<i>BIOS - Boot BIOS version 115 and higher on page A-41</i>
Intel® Celeron® 3965U	Up to version BU□□□008	<i>BIOS - Boot BIOS up to version 008 on page A-40</i>
	Version BU□□□115 and higher	<i>BIOS - Boot BIOS version 115 and higher on page A-41</i>
Intel® Core™ i7-7820EQ	All versions	<i>BIOS - Boot for CPU Type Intel® Core™ i7-7820EQ on page A-42</i>

● **BIOS - Boot BIOS up to version 008**

This section provides BIOS Boot information for 7<sup>th</sup> generation CPUs with a BIOS version up to B□□□008.

Changeable BIOS Boot parameters and their factory default values:

Item		Default / Remark
Quiet Boot		Disabled
Setup Prompt Timeout		1
Bootup NumLock State		On
Power Loss Control *1		Remain Off
AT Shutdown Mode		Hot S5
Enter Setup If No Boot Device		No
Enable Popup Boot Menu		Yes
Boot Priority Selection		Type Based
Boot Option Sorting Method		UEFI First
Type Based Boot Priority	1st Boot Device	SATA 1 Drive
	2nd Boot Device	Disabled
	3rd Boot Device	Disabled
	4th Boot Device	Disabled
	5th Boot Device	Disabled
	6th Boot Device	Disabled
	7th Boot Device	Disabled
	8th Boot Device	Disabled
Battery Support		Auto (Battery Manager)
System Off Mode		G3/Mech Off
UEFI Fast Boot		Disabled
UEFI Screenshot Capability		Disabled

\*1. Power Loss Control settings are :

Remain OFF: The Industrial Panel PC will stay OFF when power is supplied to the power connector

Turn ON: The Industrial Panel PC will automatically start up when power is supplied to the power connector.

Last State: The Industrial Panel PC will start up or remain OFF when power is supplied based on the Industrial Panel PC state at the moment power was removed from the power connector.

## ● BIOS - Boot BIOS version 115 and higher

This section provides Advanced BIOS information for 7<sup>th</sup> generation CPUs:

- Intel® Core™ i5-7300U with a BIOS version BU□□□115 and higher
- Intel® Celeron® 3965U with a BIOS version BV□□□115 and higher

For all other CPU types or BIOS versions refer to *BIOS - Advanced* on page A-15 for details.

Changeable BIOS Boot parameters and their factory default values:

Item	Default / Remark
Quiet Boot	Disabled
Setup Prompt Timeout	2
Bootup NumLock State	On
Power Loss Control *1	Remain Off
Enter Setup If No Boot Device	No
Enable Popup Boot Menu	Yes
Boot Priority Selection	UEFI Standard
Boot Option #1*2	UEFI OS (P1: □)
Boot Option #2*2	Windows Boot Manager (P1: □)
UEFI Fast Boot	Disabled
UEFI Screenshot Capability	Disabled
New Boot Option Policy	Default

\*1. Power Loss Control settings are :

Remain OFF: The Industrial Panel PC will stay OFF when power is supplied to the power connector

Turn ON: The Industrial Panel PC will automatically start up when power is supplied to the power connector.

Last State: The Industrial Panel PC will start up or remain OFF when power is supplied based on the Industrial Panel PC state at the moment power was removed from the power connector.

\*2. For Intel® Core™ i5-7300U Setup Prompt Timeout = 1

\*3. For Intel® Core™ i5-7300U:

Boot Option #1 = Windows Boot Manager (P1: □)

Boot Option #2 = UEFI OS (P1: □)

● **BIOS - Boot for CPU Type Intel® Core™ i7-7820EQ**

This section provides BIOS Boot information for CPU type Intel® Core™ i7-7820EQ.

Changeable BIOS Boot parameters and their factory default values:

Item	Default / Remark
Quiet Boot	Disabled
Setup Prompt Timeout	1
Bootup NumLock State	On
Power Loss Control *1	Remain Off
Enter Setup If No Boot Device	No
Enable Popup Boot Menu	Yes
Boot Priority Selection	Type Based
Boot Option #1	Windows Boot Manager (P1: □)
Boot Option #2	UEFI OS (P1: □)
UEFI Fast Boot	Disabled
UEFI Screenshot Capability	Disabled
New Boot Option Policy	Default

\*1. Power Loss Control settings are :

Remain OFF: The Industrial Panel PC will stay OFF when power is supplied to the power connector

Turn ON: The Industrial Panel PC will automatically start up when power is supplied to the power connector.

Last State: The Industrial Panel PC will start up or remain OFF when power is supplied based on the Industrial Panel PC state at the moment power was removed from the power connector.

## BIOS - Save & Exit

Provides the possibility to leave the BIOS with or without saving changes and to create or restore a set of User Defaults.

Save & Exit Parameters:

- **Save Changes and Exit**  
Changed settings are saved and the Operating System starts with the changed settings.
- **Discard Changes and Exit**  
Changed settings are not saved and the Operating System starts with the unchanged settings.
- **Save Changes and Reset**  
Changed settings are saved and the Panel PC restarts using the changed settings.
- **Discard Changes and Reset**  
Changed settings are not saved and the Panel PC restarts with the unchanged settings.
- **Save Changes**  
Changed settings are saved and the BIOS setup stays open.
- **Discard Changes**  
Changed settings are reverted to their last saved values and the BIOS setup stays open.
- **Restore Defaults**  
Revert all BIOS settings to factory default.
- **Save as User Defaults**  
Saves the BIOS values as a User Defaults set.
- **Restore User Defaults**  
Restores the User Defaults set to the BIOS.

Only for CPU type Intel® Celeron® 3965U with BIOS version BU□□□115 and higher and for CPU type Intel® Core™ i7-7820EQ:

- UEFI OS (P1: )  
Boots the system with the UEFI OS.
- Windows Boot Manager (P1: )  
Boots the system with the Windows Boot Manager.

## A-1-4 BIOS for 11<sup>th</sup> generation CPU - CVWNA111 CVWNR111 CVWGR111

Changeable BIOS Chipset parameters and their factory default values for BIOS CVWNA111, CVWNR111 and CVWGR111.

Refer to the CPU information in *1-4 Product Configuration Panel PC* on page 1-5 for generation details.

The BIOS is divided in the pages Main, Advanced, Chipset, Security, Boot and Save&Exit.

### BIOS - Main

The main setup screen gives platform information about the BIOS, Board Information, Firmware Revision, MAC Addresses and information about the number of Boots and the Running Time. Platform Information gives CPU and platform details.

Changeable BIOS Main parameters and their factory default values:

Item	Default / Remark
<b>Main</b>	
System Date	<b>System Date</b> Use the <b>Enter</b> key to the next Date field.
System Time	<b>System Time</b> Use the <b>Enter</b> key to the next Time field.
<b>Main / License Information</b>	
License message	Disabled

## BIOS - Advanced

This section provides Advanced BIOS information for 11<sup>th</sup> generation CPUs with BIOS CVWNA111, CVWNR111 and CVWGR111.

Changeable BIOS Advanced parameters and their factory default values are grouped with the combination of your CPU type and the BIOS version.

Item	Default / Remark
<b>Advanced</b>	
<b>Advanced</b>	
<b>Advanced / CPU</b>	
Hardware Prefetcher	Enabled
Adjacent Cache Line Prefetch	Enabled
Intel (VMX) Virtualization Technology	Enabled
AVX	Enabled
AVX3	Enabled
Active Processor Cores	All
Hyper-Threading	Enabled
BIST	Disabled
AP threads Idle Manner	MWAIT Loop
AES	Enabled
MachineCheck	Disabled
RaceConditionResponse Policy	Disabled
<b>Advanced / Power &amp; Performance</b>	
<b>Advanced / Power &amp; Performance / CPU - Power Management Control</b>	
Boot performance mode	[Max Non-Turbo Performance]
Intel(R) SpeedStep(tm)	Enabled
Race To Halt (RTH)	Enabled
Intel(R) Speed Shift Technology	Enabled
Per Core P State OS control mode	Enabled
Turbo Mode	Enabled
C states	Disabled
Timed MWAIT	Disabled
<b>Advanced / Power &amp; Performance / GT - Power Management Control</b>	
Maximum GT frequency	Default Max Frequency
Disable Turbo GT frequency	Enabled for CVWNA111 Disabled for CUWNR111, CVWGR111
<b>Advanced / Intel(R) Time Coordinated Computing</b>	
#AC Split Lock	Disabled
IFU Enable	Disabled
Software SRAM	Disabled
Data Streams Optimizer	Disabled
Error Log	Enabled
Intel(R) TCC Mode	Disabled
IO Fabric Low Latency	Enabled
GT CLOS	Disabled
OPIO Recentering	Disabled
<b>Advanced / Intel(R) Time Coordinated Computing / Intel(R) TCC Authentication Menu</b>	

Item	Default / Remark
Intel(R) TCC Authentication	OEM Enrolled Key
<b>Advanced / Hardware Health Monitoring</b> only for BIOS CVWGR111	
Fan Control Temperature	CPU Temperature
Lower Temperature Threshold	50 C
Upper Temperature Threshold	80 C
Minimum Fan Speed	Fan Off
Lower Temperature Fan Speed	30%
Upper Temperature Fan Speed	100%
Maximum Fan Speed	100%
<b>Advanced / Trusted Computing</b>	
Security Device Support	Enable
SHA256 PCR Bank	Enabled
Pending operation	None
Platform Hierarchy	Enabled
Storage Hierarchy	Enabled
Endorsement Hierarchy	Enabled
Physical Presence Spec Version	1.3
Device Select	Auto
<b>Advanced / USB</b>	
Legacy USB Support	Enabled
xHCI Hand-off	Enabled
USB Mass Storage Driver Support	Enabled
USB Transfer Timeout	20 sec
Device Reset Timeout	20 sec
Device Power-up Delay Selection	Auto
<b>Advanced / Network Boot</b>	
UEFI Network Stack	Disabled
<b>Advanced / NVMe Configuration</b>	
<b>Advanced / Boot Delay Settings</b>	
Seconds to Delay Before Memory Detection	0
Seconds to Delay After Memory Detection	0
Seconds to Delay Before PCI Enumeration	0
Seconds to Delay After PCI Enumeration	0
<b>Advanced / RTC Wake Settings</b>	
RTC Wake Mode	Disabled
<b>Advanced / Power On Delay</b>	
Power On Delay	100 ms

## BIOS - Chipset

This section provides Chipset BIOS information for 11<sup>th</sup> generation CPUs with BIOS CVWNA111, CVWNR111 and CVWGR111.

Changeable BIOS Advanced parameters and their factory default values are grouped with the combination of your CPU type and the BIOS version.

Item	Default / Remark
<b>Chipset</b>	
<b>Chipset / Processor (Integrated Components)</b>	
VT-d	Enabled
GNA Device (B0:D8:F0)	Enabled
Above 4GB MMIO BIOS assignment	Enabled
<b>Chipset / Processor (Integrated Components) / Memory Configuration</b>	
Max TOLUD	Dynamic
Extended Bank Hashing	Enabled
Per Bank Refresh	Enabled
In-Band ECC Support	Disabled
Memory Remap	Enabled
<b>Chipset / Processor (Integrated Components) / Graphics Configuration</b>	
Skip Scanning of External Gfx Card	Disabled
Primary Display	Auto
Select PCIE Card	Auto
Internal Graphics Device	Auto
GTT Size	8MB
Aperture Size	256MB
IGD Pre-Allocated Graphics Memory	60M
IGD Total Graphics Memory	256M
<b>Chipset / Processor (Integrated Components) / Graphics Configuration / External Gfx Card Primary Display Configuration</b>	
Primary PEG	Auto
Primary PCIE	Auto
<b>Chipset / Processor (Integrated Components) / PCI Express Configuration</b>	
PCIe function swap	Enabled
<b>Chipset / Processor (Integrated Components) / PCI Express Configuration / PCI Express Slot Root Port</b>	
PCI Express Slot Root Port	Enabled
ASPM	Disabled
PTM	Enabled
VC	Enabled
Multi-VC	Disabled
EDPC	Disabled
Hot Plug	Disabled
PCIe Speed	Auto
<b>Chipset / Platform Controller Hub (PCH)</b>	
Isolate SMBus Segments	Always
Legacy IO Low Latency	Enabled
Pcie Ref Pll SSC	Auto
IOAPIC 24-119 Entries	Enabled

Item	Default / Remark
Enable 8254 Clock Gate	Disabled
Hybrid Storage Detection and Configuration Mode	Disabled
<b>Chipset / Platform Controller Hub (PCH) / PCI Express Configuration</b>	
<b>Chipset / Platform Controller Hub (PCH) / PCI Express Configuration / Ethernet Port 2</b>	
PCI Express Root Port 5	Enabled
ASPM	Disabled
PTM	Enabled
<b>Chipset / Platform Controller Hub (PCH) / PCI Express Configuration / Ethernet Port 3</b>	
PCI Express Root Port 6	Enabled
ASPM	Disabled
PTM	Enabled
<b>Chipset / Platform Controller Hub (PCH) / PCI Express Configuration / Ethernet Port 1</b>	
PCI Express Root Port 9	Enabled
ASPM	Disabled
PTM	Enabled
<b>Chipset / Platform Controller Hub (PCH) / PCI Express Configuration / Option Board Port</b>	
PCI Express Root Port 10	Enabled
ASPM	Disabled
PTM	Enabled
PCIe Speed	Auto
<b>Chipset / Platform Controller Hub (PCH) / SATA And RST Configuration</b>	
SATA Controller(s)	Enabled
SATA Mode Selection	AHCI
SATA Port	Enabled
SATA Port	Enabled
<b>Chipset / Platform Controller Hub (PCH) / USB Configuration</b>	
USB Overcurrent	Enabled
USB Overcurrent Lock	Enabled
USB Port Disable Override	Disabled

The Chipset BIOS CVWNR111 has additional:

Item	Default / Remark
<b>Chipset / Platform Controller Hub (PCH) / Seriallo Configuration</b>	
I2C0 Controller	Disabled
I2C4 Controller	Disabled
I2C5 Controller	Disabled
I2C6 Controller	Disabled
I2C7 Controller	Disabled
SPI0 Controller	Disabled
SPI1 Controller	Disabled
SPI2 Controller	Disabled
SPI3 Controller	Disabled
SPI4 Controller	Disabled
SPI5 Controller	Disabled
SPI6 Controller	Disabled
UART0 Controller	Disabled
UART1 Controller	Disabled

Item	Default / Remark
UART2 Controller	Disabled
UART3 Controller	Disabled
UART4 Controller	Disabled
UART5 Controller	Disabled
UART6 Controller	Disabled
Seriallo D3 State	Enabled
GPIO IRQ Route	IRQ14
WITT/MITT Test Device	Disabled
UART Test Device	Disabled
Additional Serial IO devices	Disabled
SerialIO timing parameters	Disabled

**A**

## BIOS - Security

This section provides Security BIOS information for 11<sup>th</sup> generation CPUs with BIOS CVWNA111, CVWNR111 and CVWGR111.

Changeable BIOS Advanced parameters and their factory default values are grouped with the combination of your CPU type and the BIOS version.

### **WARNING**

Security setting adjustments should only be performed by the engineer in charge that possesses a thorough understanding of the security settings. Selecting non-recommended security settings can put your system at risk.



Changeable BIOS Security parameters and their factory default values:

Item	Default / Remark
<b>Security</b>	
BIOS Lock	Enabled
Storage Media Security	SAT3
<b>Security / Secure Boot Menu</b>	
Secure Boot	Disabled
Secure Boot Mode	Standard

## BIOS - Boot

This section provides Boot BIOS information for 11<sup>th</sup> generation CPUs with BIOS CVWNA111, CVWNR111 and CVWGR111.

Changeable BIOS Advanced parameters and their factory default values are grouped with the combination of your CPU type and the BIOS version.

Item	Default / Remark
<b>Boot</b>	
Setup Prompt Timeout	1
Bootup NumLock State	On
Power Loss Control	Remain Off
Prevent auto-start without RTC wake-up	Enabled
Enter Setup If No Boot Device	No
Enable Popup Boot Menu	Yes
Boot Priority Selection	Type Based
1st Boot Device	SATA 0 Drive
2nd Boot Device	SATA 1 Drive
3rd Boot Device	USB Harddisk
4th Boot Device	Other USB Device
5th Boot Device	Disabled
6th Boot Device	NVMe Storage
7th Boot Device	Onboard LAN
8th Boot Device	Other Device
Quiet Boot	Disabled
UEFI Fast Boot	Disabled
S5e	Disabled
UEFI Screenshot Capability	Disabled

## BIOS - Save & Exit

---

Provides the possibility to leave the BIOS with or without saving changes and to create or restore a set of User Defaults.

Save & Exit Parameters:

- **Save Changes and Exit**  
Changed settings are saved and the Operating System starts with the changed settings.
- **Discard Changes and Exit**  
Changed settings are not saved and the Operating System starts with the unchanged settings.
- **Save Changes and Reset**  
Changed settings are saved and the Panel PC restarts using the changed settings.
- **Discard Changes and Reset**  
Changed settings are not saved and the Panel PC restarts with the unchanged settings.
- **Save Changes**  
Changed settings are saved and the BIOS setup stays open.
- **Discard Changes**  
Changed settings are reverted to their last saved values and the BIOS setup stays open.
- **Restore Defaults**  
Revert all BIOS settings to factory default.
- **Save as User Defaults**  
Saves the BIOS values as a User Defaults set.
- **Restore User Defaults**  
Restores the User Defaults set to the BIOS.

Optional a BIOS versions can also have following options:

- **UEFI OS (P1:...)**  
Boots the system with the UEFI OS.
- **Windows Boot Manager (P1:...)**  
Boots the system with the Windows Boot Manager.

## A-1-5 BIOS for 11<sup>th</sup> generation CPU - CQWGA111

Changeable BIOS Chipset parameters and their factory default values for BIOS CQWGA111. Refer to the CPU information in *1-4 Product Configuration Panel PC* on page 1-5 for generation details.

The BIOS is divided in the pages Main, Advanced, Chipset, Security, Boot and Save&Exit.

### BIOS - Main

The main setup screen gives platform information about the BIOS, Board Information, Firmware Revision, MAC Addresses and information about the number of Boots and the Running Time. Platform Information gives CPU and platform details.

Changeable BIOS Main parameters and their factory default values:

Item	Default / Remark
<b>Main</b>	
System Date	<b>System Date</b> Use the <b>Enter</b> key to the next Date field.
System Time	<b>System Time</b> Use the <b>Enter</b> key to the next Time field.
<b>Main / License Information</b>	
License message	Disabled

## BIOS - Advanced - CQWGA111

This section provides Advanced BIOS information for 11<sup>th</sup> generation CPUs with BIOS CQWGA111. Changeable BIOS Advanced parameters and their factory default values are grouped with the combination of your CPU type and the BIOS version.

Item	Default / Remark
<b>Advanced</b>	
<b>Advanced / CPU</b>	
Hardware Prefetcher	Enabled
Adjacent Cache Line Prefetch	Enabled
Intel (VMX) Virtualization Technology	Enabled
AVX	Enabled
AVX3	Enabled
Active Processor Cores	All
Hyper-Threading	Enabled
BIST	Disabled
AP threads Idle Manner	MWAIT Loop
AES	Enabled
MachineCheck	Disabled
<b>Advanced / Power &amp; Performance</b>	
<b>Advanced / Power &amp; Performance / CPU - Power Management Control</b>	
Boot performance mode	[Max Non-Turbo Performance]
Intel(R) SpeedStep(tm)	Enabled
Race To Halt (RTH)	Enabled
Intel(R) Speed Shift Technology	Enabled
Per Core P State OS control mode	Enabled
Turbo Mode	Enabled
C states	Disabled
Timed MWAIT	Disabled
<b>Advanced / Power &amp; Performance / GT - Power Management Control</b>	
Maximum GT frequency	Default Max Frequency
Disable Turbo GT frequency	Disabled
<b>Advanced / Intel(R) Time Coordinated Computing</b>	
#AC Split Lock	Disabled
IFU Enable	Disabled
Software SRAM	Disabled
Data Streams Optimizer	Disabled
Error Log	Enabled
Intel(R) TCC Mode	Disabled
IO Fabric Low Latency	Enabled
GT CLOS	Disabled
OPIO Recentering	Disabled
<b>Advanced / Intel(R) Time Coordinated Computing / Intel(R) TCC Authentication Menu</b>	
Intel(R) TCC Authentication	OEM Enrolled Key
<b>Advanced / Hardware Health Monitoring</b>	
Fan Control Temperature	CPU Temperature

Item	Default / Remark
Lower Temperature Threshold	50 C
Upper Temperature Threshold	80 C
Minimum Fan Speed	Fan Off
Lower Temperature Fan Speed	30%
Upper Temperature Fan Speed	100%
Maximum Fan Speed	100%
<b>Advanced / Trusted Computing</b>	
Security Device Support	Enable
SHA256 PCR Bank	Enabled
Pending operation	None
Platform Hierarchy	Enabled
Storage Hierarchy	Enabled
Endorsement Hierarchy	Enabled
Physical Presence Spec Version	1.3
Device Select	Auto
<b>Advanced / USB</b>	
Legacy USB Support	Enabled
xHCI Hand-off	Enabled
USB Mass Storage Driver Support	Enabled
USB Transfer Timeout	20 sec
Device Reset Timeout	20 sec
Device Power-up Delay Selection	Auto
<b>Advanced / Network Boot</b>	
UEFI Network Stack	Disabled
<b>Advanced / NVMe Configuration</b>	
<b>Advanced / Boot Delay Settings</b>	
Seconds to Delay Before Memory Detection	0
Seconds to Delay After Memory Detection	0
Seconds to Delay Before PCI Enumeration	0
Seconds to Delay After PCI Enumeration	0
<b>Advanced / RTC Wake Settings</b>	
RTC Wake Mode	Disabled
<b>Advanced / Power On Delay</b>	
Power On Delay	100 ms

## BIOS - Chipset - CQWGA111

This section provides Chipset BIOS information for 11<sup>th</sup> generation CPUs with BIOS CQWGA111. Changeable BIOS Advanced parameters and their factory default values are grouped with the combination of your CPU type and the BIOS version.

Item	Default / Remark
<b>Chipset</b>	
<b>Chipset / Processor (Integrated Components)</b>	
VT-d	Enabled
GNA Device (B0:D8:F0)	Enabled
Above 4GB MMIO BIOS assignment	Enabled
<b>Chipset / Processor (Integrated Components) / Memory Configuration</b>	
Max TOLUD	Dynamic
Extended Bank Hashing	Enabled
Per Bank Refresh	Enabled
Memory Remap	Enabled
<b>Chipset / Processor (Integrated Components) / Graphics Configuration</b>	
Skip Scanning of External Gfx Card	Disabled
Primary Display	Auto
Select PCIE Card	Auto
Internal Graphics Device	Auto
GTT Size	8MB
Aperture Size	256MB
IGD Pre-Allocated Graphics Memory	60M
IGD Total Graphics Memory	256M
<b>Chipset / Processor (Integrated Components) / Graphics Configuration / External Gfx Card Primary Display Configuration</b>	
Primary PEG	Auto
Primary PCIE	Auto
<b>Chipset / Processor (Integrated Components) / PCI Express x4 Slot Configuration</b>	
PCIe function swap	Enabled
<b>Chipset / Processor (Integrated Components) / PCI Express x4 Slot Configuration / PCI Express x4 Slot A</b>	
PEG10 Root Port(x16 or x8)	Enabled
ASPM	Disabled
PTM	Enabled
VC	Enabled
EDPC	Disabled
Hot Plug	Disabled
PCIe Speed	Auto
<b>Chipset / Processor (Integrated Components) / PCI Express x4 Slot Configuration / PCI Express x4 Slot B</b>	
PEG11 Root Port(x8 or x4)	Enabled
ASPM	Disabled
PTM	Enabled
VC	Enabled
EDPC	Disabled

Item	Default / Remark
Hot Plug	Disabled
PCIe Speed	Auto
<b>Chipset / Platform Controller Hub (PCH)</b>	
Isolate SMBus Segments	Always
Legacy IO Low Latency	Enabled
Pcie Ref Pll SSC	Auto
Enable 8254 Clock Gate	Disabled
Hybrid Storage Detection and Configuration Mode	Disabled
<b>Chipset / Platform Controller Hub (PCH) / PCI Express x4 Slot Configuration</b>	
<b>Chipset / Platform Controller Hub (PCH) / PCI Express x4 Slot Configuration / Ethernet Port 2</b>	
PCI Express Root Port 5	Enabled
ASPM	Disabled
PTM	Enabled
<b>Chipset / Platform Controller Hub (PCH) / PCI Express x4 Slot Configuration / Ethernet Port 3</b>	
PCI Express Root Port 6	Enabled
ASPM	Disabled
PTM	Enabled
<b>Chipset / Platform Controller Hub (PCH) / PCI Express x4 Slot Configuration / Ethernet Port 1</b>	
PCI Express Root Port 9	Enabled
ASPM	Disabled
PTM	Enabled
<b>Chipset / Platform Controller Hub (PCH) / PCI Express x4 Slot Configuration / Option Board Port</b>	
PCI Express Root Port 17	Enabled
ASPM	Disabled
PTM	Enabled
PCIe Speed	Auto
<b>Chipset / Platform Controller Hub (PCH) / PCI Express x4 Slot Configuration / PCI Express x1 slot</b>	
PCI Express Root Port 18	Enabled
ASPM	Disabled
PTM	Enabled
PCIe Speed	Auto
<b>Chipset / Platform Controller Hub (PCH) / SATA And RST Configuration</b>	
SATA Controller(s)	Enabled
SATA Mode Selection	AHCI
SATA Port	Enabled
SATA Port	Enabled
SATA Port	Enabled
External	Disabled
SATA Device Type	Hard Disk Drive
SATA Port	Enabled
External	Disabled
SATA Device Type	Hard Disk Drive
<b>Chipset / Platform Controller Hub (PCH) / USB Configuration</b>	
USB Overcurrent	Enabled
USB Overcurrent Lock	Enabled
USB Port Disable Override	Disabled

## BIOS - Security - CQWGA111

This section provides Security BIOS information for 11<sup>th</sup> generation CPUs with BIOS CQWGA111. Changeable BIOS Advanced parameters and their factory default values are grouped with the combination of your CPU type and the BIOS version.

### **WARNING**

Security setting adjustments should only be performed by the engineer in charge that possesses a thorough understanding of the security settings. Selecting non-recommended security settings can put your system at risk.



Changeable BIOS Security parameters and their factory default values:

Item	Default / Remark
<b>Security</b>	
BIOS Lock	Enabled
Storage Media Security	SAT3
<b>Security / Secure Boot Menu</b>	
Secure Boot	Disabled
Secure Boot Mode	Standard

## BIOS - Boot - CQWGA111

This section provides Boot BIOS information for 11<sup>th</sup> generation CPUs with BIOS CQWGA111. Changeable BIOS Advanced parameters and their factory default values are grouped with the combination of your CPU type and the BIOS version.

Item	Default / Remark
<b>Boot</b>	
Setup Prompt Timeout	1
Bootup NumLock State	On
Power Loss Control	Remain Off
Prevent auto-start without RTC wake-up	Enabled
Enter Setup If No Boot Device	No
Enable Popup Boot Menu	Yes
Boot Priority Selection	Type Based
1st Boot Device	SATA 0 Drive
2nd Boot Device	SATA 1 Drive
3rd Boot Device	USB Harddisk
4th Boot Device	Other USB Device
5th Boot Device	SATA 2 Drive
6th Boot Device	SATA 3 Drive
7th Boot Device	Onboard LAN
8th Boot Device	NVMe Storage
Quiet Boot	Disabled
UEFI Fast Boot	Disabled
S5e	Disabled
UEFI Screenshot Capability	Disabled

## BIOS - Save & Exit

---

Provides the possibility to leave the BIOS with or without saving changes and to create or restore a set of User Defaults.

Save & Exit Parameters:

- **Save Changes and Exit**  
Changed settings are saved and the Operating System starts with the changed settings.
- **Discard Changes and Exit**  
Changed settings are not saved and the Operating System starts with the unchanged settings.
- **Save Changes and Reset**  
Changed settings are saved and the Panel PC restarts using the changed settings.
- **Discard Changes and Reset**  
Changed settings are not saved and the Panel PC restarts with the unchanged settings.
- **Save Changes**  
Changed settings are saved and the BIOS setup stays open.
- **Discard Changes**  
Changed settings are reverted to their last saved values and the BIOS setup stays open.
- **Restore Defaults**  
Revert all BIOS settings to factory default.
- **Save as User Defaults**  
Saves the BIOS values as a User Defaults set.
- **Restore User Defaults**  
Restores the User Defaults set to the BIOS.

Optional a BIOS versions can also have following options:

- **UEFI OS (P1:...)**  
Boots the system with the UEFI OS.
- **Windows Boot Manager (P1:...)**  
Boots the system with the Windows Boot Manager.

## A-1-6 BIOS for Atom CPU - 1AWGR113

The BIOS settings for Atom CPUs with BIOS 1AWGR113.

The BIOS is divided in the pages Main, Advanced, Chipset, Security, Boot and Save&Exit.

### BIOS - Main

---

The main setup screen gives platform information about the BIOS, Board Information, Firmware Revision, MAC Addresses and information about the number of Boots and the Running Time. Platform Information gives CPU and platform details.

Changeable BIOS Main parameters and their factory default values:

- **System Date**  
Use the **Enter** key to the next Date field.
- **System Time**  
Use the **Enter** key to the next Time field.

## BIOS - Advanced - 1AWGR113

This section provides Advanced BIOS information for a Panel PC with an Atom CPU and BIOS 1AWGR113.

Changeable BIOS Advanced parameters and their factory default values:

Item		Default / Remark	
Trusted Computing	Security Device Support	Enabled	
	SHA-1 PCR Bank	Enabled	
	SHA256 PCR Bank	Enabled	
	Pending operation	None	
	Platform Hierarchy	Enabled	
	Storage Hierarchy	Enabled	
	Endorsement Hierarchy	Enabled	
	TPM2.0 UEFI Spec Version	TCG_2	
	Physical Presence Spec Version	1.3	
	Device Select	Auto	
RTC Wake Settings	RTC Wake Mode	Disabled	
CPU	CPU Power Management	EIST	Enabled
		Turbo Mode	Enabled
		C-States	Disabled
	Active Processor Cores	Disabled	
	Intel Virtualization Technology	Enabled	
	VT-d	Enabled	
	Monitor Mwait	Auto	
AMI Graphic Output Protocol Policy	Output Select	DVI2	
UEFI Network Stack	UEFI Network Stack	Disabled	
CSM & Option ROM Control	CSM Support	Disabled	
USB	Legacy USB Support	Enabled	
	xHCI Hand-off	Enabled	
	USB Mass Storage Driver Support	Enabled	
	USB Transfer Timeout	20 sec	
	Device Reset Timeout	20 sec	
	Device Power-up Delay Selection	Auto	
	Generic Ultra HS-COMBO	Auto	

## BIOS - Chipset - 1AWGR113

This section provides Chipset information for a Panel PC with an Atom CPU and BIOS 1AWGR113.

Changeable BIOS Chipset parameters and their factory default values:

Item		Default / Remark	
<b>Processor (Integrated Components)</b>	Max TOLUD	2 GB	
	Above 4GB MMIO BIOS assignment	Disabled	
<b>Extention Graphic Configuration</b>	GOP Driver	Enabled	
	Intel Graphics Pei Display Peim	Disabled	
	Integrated Graphics Device	Enabled	
	Primary Display	IGD	
	RC6(Render Standby)	Disabled	
	GTT Size	8MB	
	Aperture Size	256MB	
	IGD Pre-Allocated Graphics Memory	64M	
	IGD Total Graphics Memory	256M	
GT PM Support	Enabled		
<b>South Cluster Configuration</b>	SATA Drives	Chipset SATA	Enabled
		SATA Port 0	Enabled
		SATA Port 1	Enabled
	USB Configuration	USB Port Disable Override	Disabled
	Miscellaneous Config-uration	Wake On Lan	Disabled

## BIOS - Security - 1AWGR113

Provides security information like BIOS Password and HDD information for a Panel PC with an Atom CPU and BIOS 1AWGR113.

### WARNING

Security setting adjustments should only be performed by the engineer in charge that possesses a thorough understanding of the security settings. Selecting non-recommended security settings can put your system at risk.

Changeable BIOS Security parameters and their factory default values:

Item		Default / Remark	
<b>BIOS Password</b>		Empty	
P1: CFast <input type="checkbox"/>	Set User Password	Empty	
<b>Secure Boot Menu</b>	Secure Boot	Disabled	
	Secure Boot Customization	Custom	
	Key Management	Factory Key Provision	Disabled
		Platform Key(PK)	0   0   No Keys
		Key Exchange Keys	
		Authorized Signatures	
		Forbidden Signatures	
Authorized TimeStamps			
	OsRecovery Signatures		

## BIOS - Boot - 1AWGR113

Provides Boot information and configuration settings for a Panel PC with an Atom CPU and BIOS 1AWGR113.

Changeable BIOS Boot parameters and their factory default values:

Item	Default / Remark
Setup Prompt Timeout	0
Bootup NumLock State	On
Enter Setup If No Boot Device	No
Enable Popup Boot Menu	Yes
Boot Priority Selection	Type Based
1st Boot Device	SATA 1 Drive
2nd Boot Device	Disabled
3rd Boot Device	Disabled
4th Boot Device	Disabled
5th Boot Device	Disabled
6th Boot Device	Disabled
7th Boot Device	Disabled
8th Boot Device	Disabled
Power Loss Control	Remain Off
Quiet Boot	Disabled
Boot Option #1	Windows Boot Manager (P1: CFast <input type="checkbox"/> )
UEFI Fast Boot	Disabled
UEFI Screenshot Capability	Enabled

\*1. Turn On for model-ID NYE□□-□□F□□

## BIOS - Save & Exit

---

Provides the possibility to leave the BIOS with or without saving changes and to create or restore a set of User Defaults.

Save & Exit Parameters:

- **Save Changes and Exit**  
Changed settings are saved and the Operating System starts with the changed settings.
- **Discard Changes and Exit**  
Changed settings are not saved and the Operating System starts with the unchanged settings.
- **Save Changes and Reset**  
Changed settings are saved and the Panel PC restarts using the changed settings.
- **Discard Changes and Reset**  
Changed settings are not saved and the Panel PC restarts with the unchanged settings.
- **Save Changes**  
Changed settings are saved and the BIOS setup stays open.
- **Discard Changes**  
Changed settings are reverted to their last saved values and the BIOS setup stays open.
- **Restore Defaults**  
Revert all BIOS settings to factory default.
- **Save as User Defaults**  
Saves the BIOS values as a User Defaults set.
- **Restore User Defaults**  
Restores the User Defaults set to the BIOS.

Optional a BIOS versions can also have following options:

- **UEFI OS (P1:...)**  
Boots the system with the UEFI OS.
- **Windows Boot Manager (P1:...)**  
Boots the system with the Windows Boot Manager.

## A-1-7 BIOS for Atom CPU - 3AWNR113

The BIOS settings for Atom CPUs with BIOS 3AWNB112.

The BIOS is divided in the pages Main, Advanced, Chipset, Security, Boot and Save&Exit.

### BIOS - Main

---

The main setup screen gives platform information about the BIOS, Board Information, Firmware Revision, MAC Addresses and information about the number of Boots and the Running Time. Platform Information gives CPU and platform details.

Changeable BIOS Main parameters and their factory default values:

- **System Date**  
Use the **Enter** key to the next Date field.
- **System Time**  
Use the **Enter** key to the next Time field.

## BIOS - Advanced - 3AWNR113

This section provides Advanced BIOS information for a Panel PC with an Atom CPU and BIOS 3AWNB112.

Changeable BIOS Advanced parameters and their factory default values:

Item	Default / Remark
<b>Advanced</b>	
<b>Advanced / CPU</b>	
Hardware Prefetcher	Enabled
Intel (VMX) Virtualization Technology	Enabled
Active Processor Cores	All
BIST	Disabled
AP threads Idle Manner	MWAIT Loop
AES	Enabled
MachineCheck	Disabled
MonitorMWait	Enabled
#AC Split Lock	Disabled
<b>Advanced / CPU / CPU SMM Enhancement</b>	
SMM Use Delay Indication	Enabled
SMM Use Block Indication	Enabled
SMM Use SMM en-US Indication	Enabled
<b>Advanced / Power &amp; Performance</b>	
<b>Advanced / Power &amp; Performance / CPU - Power Management Control</b>	
Boot performance mode	[Max Non-Turbo Performance]
Intel(R) SpeedStep(tm)	Enabled
Race To Halt (RTH)	Enabled
Intel(R) Speed Shift Technology	Enabled
C states	Disabled
Timed MWAIT	Disabled
<b>Advanced / Power &amp; Performance / GT - Power Management Control</b>	
Maximum GT frequency	Default Max Frequency
Disable Turbo GT frequency	Disabled
<b>Advanced / Intel(R) Time Coordinated Computing</b>	
Software SRAM	Disabled
Data Streams Optimizer	Disabled
Error Log	Enabled
Intel(R) TCC Mode	Disabled
IO Fabric Low Latency	Enabled
GT CLOS	Disabled
<b>Advanced / Intel(R) Time Coordinated Computing / Intel(R) TCC Authentication Menu</b>	
Intel(R) TCC Authentication	OEM Enrolled Key
<b>Advanced / Hardware Health Monitoring</b>	
<b>Advanced / Trusted Computing</b>	
Security Device Support	Enable
SHA256 PCR Bank	Enabled
Pending operation	None

Item	Default / Remark
Platform Hierarchy	Enabled
Storage Hierarchy	Enabled
Endorsement Hierarchy	Enabled
Physical Presence Spec Version	1.3
Device Select	Auto
<b>Advanced / RTC Wake Settings</b>	
RTC Wake Mode	Disabled
<b>Advanced / Power On Delay</b>	
Power On Delay	0
<b>Advanced / AMI Graphic Output Protocol Policy</b>	
Output Select	HDMI1[ACTIVE]
<b>Advanced / USB</b>	
Legacy USB Support	Enabled
xHCI Hand-off	Enabled
USB Mass Storage Driver Support	Enabled
USB Transfer Timeout	20 sec
Device Reset Timeout	20 sec
Device Power-up Delay Selection	Auto
<b>Advanced / Network Boot</b>	
UEFI Network Stack	Disabled
<b>Advanced / NVMe Configuration</b>	
<b>Advanced / Boot Delay Settings</b>	
Seconds to Delay Before Memory Detection	0
Seconds to Delay After Memory Detection	0
Seconds to Delay Before PCI Enumeration	0
Seconds to Delay After PCI Enumeration	0

## BIOS - Chipset - 3AWNR113

This section provides Chipset information for a Panel PC with an Atom CPU and BIOS 3AWNB112.

Changeable BIOS Chipset parameters and their factory default values:

Item	Default / Remark
<b>Chipset</b>	
<b>Chipset / Processor (Integrated Components)</b>	
VT-d	Enabled
IGD VTD Enable	Enabled
IOP VTD Enable	Enabled
GNA Device (B0:D8:F0)	Enabled
Above 4GB MMIO BIOS assignment	Enabled
<b>Chipset / Processor (Integrated Components) / Memory Configuration</b>	
Max TOLUD	Dynamic
In-Band ECC	Disabled
Memory Remap	Enabled
<b>Chipset / Processor (Integrated Components) / Graphics Configuration</b>	
Skip Scanning of External Gfx Card	Disabled
Primary Display	Auto
Internal Graphics Device	Auto
GTT Size	8MB
Aperture Size	256MB
IGD Pre-Allocated Graphics Memory	60M
IGD Total Graphics Memory	256M
<b>Chipset / Processor (Integrated Components) / Graphics Configuration / External Gfx Card Primary Display Configuration</b>	
Primary PCIE	Auto
<b>Chipset / Platform Controller Hub (PCH)</b>	
Isolate SMBus Segments	Always
PCH Master Clock Gating Control	Default
PCH Master Power Gating Control	Disabled
Legacy IO Low Latency	Enabled
Pcie Ref PII SSC	Auto
IOAPIC 24-119 Entries	Enabled
Enable 8254 Clock Gate	Disabled
<b>Chipset / Platform Controller Hub (PCH) / PCI Express Configuration</b>	
PCH PCI Express Clock Gating	Disabled
<b>Chipset / Platform Controller Hub (PCH) / PCI Express Configuration / Ethernet Port 2</b>	
PCI Express Root Port 1	Enabled
ASPM	Disabled
PTM	Disabled
<b>Chipset / Platform Controller Hub (PCH) / PCI Express Configuration / Ethernet Port 3</b>	
PCI Express Root Port 2	Enabled
ASPM	Disabled
PTM	Disabled
<b>Chipset / Platform Controller Hub (PCH) / PCI Express Configuration / PCI Express x1 slot</b>	
PCI Express Root Port 5	Enabled

Item	Default / Remark
ASPM	Disabled
Multi-VC	Enabled
PTM	Disabled
PCIe Speed	Auto
<b>Chipset / Platform Controller Hub (PCH) / PCI Express Configuration / PCI Express x1 slot / VC to TC Mapping</b>	
TC1	VC0
TC2	VC0
TC3	VC0
TC4	VC0
TC5	VC0
TC6	VC1
TC7	VC1
<b>Chipset / Platform Controller Hub (PCH) / PCI Express Configuration / Option Board Port</b>	
PCI Express Root Port 7	Enabled
ASPM	Disabled
Multi-VC	Enabled
PTM	Disabled
PCIe Speed	Auto
<b>Chipset / Platform Controller Hub (PCH) / PCI Express Configuration / Option Board Port / VC to TC Mapping</b>	
TC1	VC0
TC2	VC0
TC3	VC0
TC4	VC0
TC5	VC0
TC6	VC1
TC7	VC1
<b>Chipset / Platform Controller Hub (PCH) / SATA Configuration</b>	
SATA Controller(s)	Enabled
SATA Mode Selection	AHCI
SATA Speed	Auto
SATA Port	Enabled
SATA Port	Enabled
<b>Chipset / Platform Controller Hub (PCH) / USB Configuration</b>	
USB Overcurrent	Enabled
USB Overcurrent Lock	Enabled
USB Port Disable Override	Disabled
USB Device/HOST Mode Override	Disabled
USB UCSI ACPI device	Disabled
<b>Chipset / Platform Controller Hub (PCH) / TSN GBE Configuration</b>	
PCH TSN LAN Controller	Disabled
PCH TSN GBE Multi-Vc	Disabled
PCH TSN GBE SGMII Support	Disabled
PCH TSN Link Speed	RefClk 38.4Mhz 1Gbps
PSE TSN GBE 0 Multi-Vc	Disabled
PSE TSN GBE 0 SGMII Support.	Disabled

Item	Default / Remark
PSE TSN GBE 0 Link Speed	RefClk 38.4Mhz 1Gbps
PSE TSN GBE 1 SGMII Support	Disabled
PSE TSN GBE 1 Link Speed	RefClk 38.4Mhz 1Gbps

## BIOS - Security - 3AWNR113

Provides security information like BIOS Password and HDD information for a Panel PC with an Atom CPU and BIOS 3AWNB112.

WARNING

Security setting adjustments should only be performed by the engineer in charge that possesses a thorough understanding of the security settings. Selecting non-recommended security settings can put your system at risk.



Changeable BIOS Security parameters and their factory default values:

Item	Default / Remark
<b>Security</b>	
BIOS Lock	Disabled
<b>Security / Secure Boot Menu</b>	
Secure Boot	Disabled
Secure Boot Mode	Standard

## BIOS - Boot - 3AWNR113

Provides Boot information and configuration settings for a Panel PC with an Atom CPU and BIOS 3AWNB112.

Changeable BIOS Boot parameters and their factory default values:

Item	Default / Remark
<b>Boot</b>	
Quiet Boot	Disabled
Setup Prompt Timeout	1
Bootup NumLock State	On
Power Loss Control	Remain Off
Enter Setup If No Boot Device	No
Enable Popup Boot Menu	Yes
Boot Priority Selection	Type Based
1st Boot Device	SATA 0 Drive
2nd Boot Device	USB Harddisk
3rd Boot Device	Other USB Device
4th Boot Device	Disabled
5th Boot Device	Disabled
6th Boot Device	Disabled
7th Boot Device	Disabled
8th Boot Device	Disabled
UEFI Fast Boot	Disabled
UEFI Screenshot Capability	Disabled
S5e	Disabled

## BIOS - Save & Exit

Provides the possibility to leave the BIOS with or without saving changes and to create or restore a set of User Defaults.

Save & Exit Parameters:

- **Save Changes and Exit**  
Changed settings are saved and the Operating System starts with the changed settings.
- **Discard Changes and Exit**  
Changed settings are not saved and the Operating System starts with the unchanged settings.
- **Save Changes and Reset**  
Changed settings are saved and the Panel PC restarts using the changed settings.
- **Discard Changes and Reset**  
Changed settings are not saved and the Panel PC restarts with the unchanged settings.
- **Save Changes**  
Changed settings are saved and the BIOS setup stays open.
- **Discard Changes**  
Changed settings are reverted to their last saved values and the BIOS setup stays open.
- **Restore Defaults**  
Revert all BIOS settings to factory default.
- **Save as User Defaults**  
Saves the BIOS values as a User Defaults set.
- **Restore User Defaults**  
Restores the User Defaults set to the BIOS.

Optional a BIOS versions can also have following options:

- **UEFI OS (P1:....)**  
Boots the system with the UEFI OS.
- **Windows Boot Manager (P1:....)**  
Boots the system with the Windows Boot Manager.

## A-2 DVI Connector Pin Details

This section provides the pin details for the DVI-I connector and for the optional DVI-D connector.

### A-2-1 DVI-I Connector Pin Details

Pin details of the DVI-I connector.

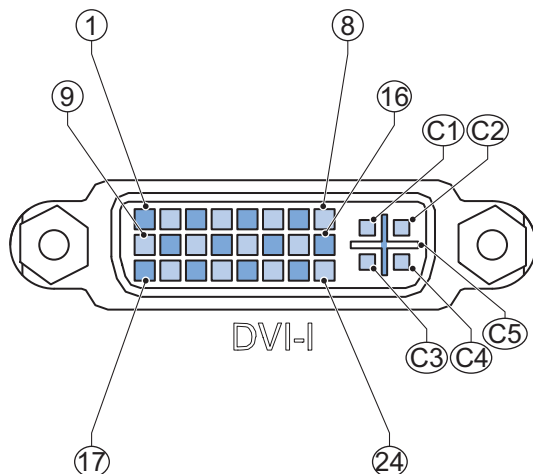

The pin layout represents the DVI-I connector on the Industrial Panel PC.

Pin numbers increase from left to right for every row.

Pin	Signal Name	Function
1	TMDS data 2-	Digital red- (link 1)
2	TMDS data 2+	Digital red+ (link 1)
3	0 VDC	TMDS data 2/4 shield
4	Not connected	---
5	Not connected	---
6	DDC clock	DDC clock
7	DDC data	DDC data
8	Analog vertical sync	Analog vertical sync *1
9	TMDS data 1-	Digital green- (link 1)
10	TMDS data 1+	Digital green+ (link 1)
11	0 VDC	TMDS data 1/3 shield
12	Not connected	---
13	Not connected	---
14	+5 V	Power for monitor DDC interface
15	0 V	Return for pin 14 and analog sync
16	HPD	Hot Plug Detect
17	TMDS data 0-	Digital blue- (link 1) and digital sync
18	TMDS data 0+	Digital blue+ (link 1) and digital sync
19	0 VDC	TMDS data 0/5 shield
20	Not connected	---
21	Not connected	---
22	0 VDC	TMDS clock shield

Pin	Signal Name	Function
23	TMDS clock+	Digital clock+
24	TMDS clock-	Digital clock-
C1	Analog red	Analog red *1
C2	Analog green	Analog green *1
C3	Analog blue	Analog blue *1
C4	Analog horizontal sync	Analog horizontal sync *1
C5	0 VDC	0 VDC *1

\*1. Only for models NY□17, NY□1E, NY□27 and NY5.

Refer to 1-4 Product Configuration Panel PC on page 1-5 for details.

## A-2-2 DVI-D Connector Pin Details

Pin details of the DVI-D connector.

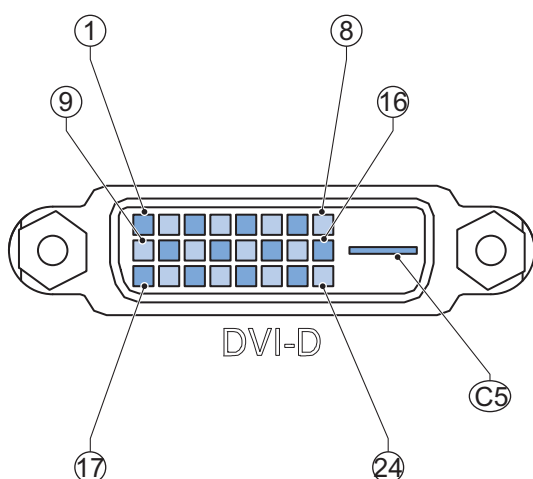

The pin layout represents the DVI connector on the Industrial Panel PC. Pin numbers increase from left to right for every row.

Pin	Signal Name	Function
1	TMDS data 2-	Digital red- (link 1)
2	TMDS data 2+	Digital red+ (link 1)
3	0 VDC	TMDS data 2/4 shield
4	Not connected	---
5	Not connected	---
6	DDC clock	DDC clock
7	DDC data	DDC data
8	Not connected	---
9	TMDS data 1-	Digital green- (link 1)
10	TMDS data 1+	Digital green+ (link 1)
11	0 VDC	TMDS data 1/3 shield
12	Not connected	---
13	Not connected	---
14	+5 V	Power for monitor DDC interface

Pin	Signal Name	Function
15	0 V	Return for pin 14
16	HPD	Hot plug detect
17	TMDS data 0-	Digital blue- (link 1) and digital sync
18	TMDS data 0+	Digital blue+ (link 1) and digital sync
19	0 VDC	TMDS data 0/5 shield
20	Not connected	---
21	Not connected	---
22	0 VDC	TMDS clock shield
23	TMDS clock+	Digital clock+
24	TMDS clock-	Digital clock-
C5	Not connected	---

# A-3 RS-232C Connector Pin Details

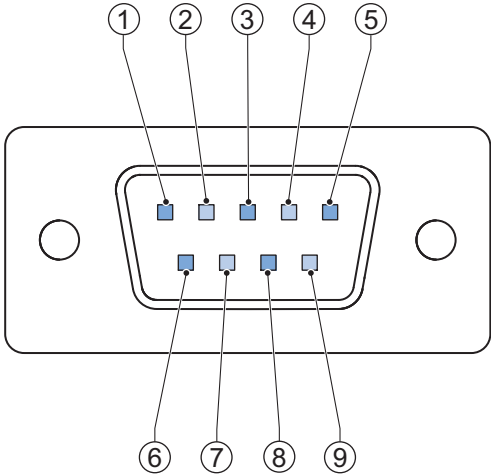

The pin layout represents the RS-232C connector on the Panel PC.

Pin	Signal Name
1	CD
2	RXD
3	TXD
4	DTR
5	0 VDC *1
6	DSR
7	RTS
8	CTS
9	RI

\*1. The 0 VDC pin is internally connected to the ground connection.



### Additional Information

Refer to 5-4-2 *Ground* on page 5-31 for grounding details.







# Index

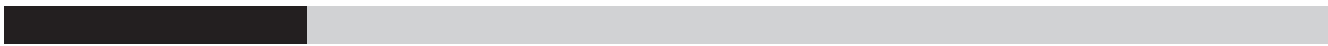

# Index

- A**
- 
- Accessory kit ..... 3-26
- B**
- 
- Backup ..... 5-60
  - Base layer ..... 3-5
  - Battery low ..... 3-9, 3-11
  - Battery Slot..... 3-22
  - Battery ..... 3-25, 7-7
    - Replace ..... 7-10
  - BIOS ..... A-2
- C**
- 
- Cables
    - Communication cable S8BW ..... 3-36
    - DVI cables ..... 3-31
    - NY Monitor Link cable ..... 3-32
    - USB Type-A - USB Type-B cable ..... 3-31
  - CFast Card Slot..... 3-21, 3-22
  - CFast Card ..... 3-28
    - Replace ..... 7-25
    - Specifications ..... 4-20
  - Configuration ..... 1-5
  - Connect ..... 5-44
  - Connectors ..... 3-26
  - Cooling distance ..... 5-16
  - Cooling layer ..... 3-4
  - Corrective maintenance ..... 7-5
  - Cover..... 7-7
  - CPU
    - Intel® Atom® x5-E3940 ..... 4-11
    - Intel® Atom® x6425RE ..... 4-12
    - Intel® Celeron® 2980U ..... 4-10
    - Intel® Celeron® 3965U ..... 4-11
    - Intel® Core™ i3-1115GRE ..... 4-10
    - Intel® Core™ i5-1145GRE ..... 4-14
    - Intel® Core™ i5-4300U ..... 4-12
    - Intel® Core™ i5-7300U ..... 4-13
    - Intel® Core™ i7-1185GRE ..... 4-13
    - Intel® Core™ i7-4700EQ ..... 4-11
    - Intel® Core™ i7-7820EQ ..... 4-12
    - Intel® Xeon® E3-1515M v5 ..... 4-10
- D**
- 
- Dimensions ..... 4-2
  - Display layer ..... 3-7
  - DisplayPort connector ..... 3-15
    - Specifications ..... 4-36
  - Drive bays..... 3-23
  - Drive
    - Install ..... 5-4
    - Replace ..... 7-15
  - Ducts ..... 5-23
  - DVI connector ..... 3-16
    - Specifications ..... 4-35
  - DVI-D connector ..... 3-17
    - Specifications ..... 4-37
- E**
- 
- Electrical
    - Specifications ..... 4-6
  - Err LED ..... 3-11
  - Ethernet connector ..... 3-19
  - Ethernet connectors ..... 3-15
    - LED indicators ..... 4-34
    - Link/Act indicator ..... 4-34
    - Specifications ..... 4-33
    - Speed indicator ..... 4-34
  - Expansion layer ..... 3-6
- F**
- 
- Fan error ..... 3-9, 3-11
  - Fan Unit ..... 3-25
    - Replace ..... 7-8
- H**
- 
- HDD LED ..... 3-11
  - HDD ..... 3-29
    - Specifications ..... 4-17
  - Humidity ..... 4-43
- I**
- 
- I/O connector ..... 3-13
    - Connections ..... 5-41
    - Specifications ..... 4-27
    - Wiring ..... 5-41, 5-43
- L**
- 
- Layers ..... 3-3
  - Led Indicators
    - Base Layer ..... 3-10
    - Display Layer ..... 3-8
  - LED indicators ..... 3-8
  - Logo LED ..... 3-9
- M**
- 
- Memory Card..... 3-20
  - Memory ..... 4-15







**OMRON Corporation Industrial Automation Company**

**Kyoto, JAPAN**

**Contact : [www.ia.omron.com](http://www.ia.omron.com)**

**Regional Headquarters**

**OMRON EUROPE B.V.**

Wegalaan 67-69, 2132 JD Hoofddorp  
The Netherlands

Tel: (31) 2356-81-300 Fax: (31) 2356-81-388

**OMRON ASIA PACIFIC PTE. LTD.**

438B Alexandra Road, #08-01/02 Alexandra  
Technopark, Singapore 119968

Tel: (65) 6835-3011 Fax: (65) 6835-3011

**OMRON ELECTRONICS LLC**

2895 Greenspoint Parkway, Suite 200  
Hoffman Estates, IL 60169 U.S.A.

Tel: (1) 847-843-7900 Fax: (1) 847-843-7787

**OMRON (CHINA) CO., LTD.**

Room 2211, Bank of China Tower,  
200 Yin Cheng Zhong Road,  
PuDong New Area, Shanghai, 200120, China

Tel: (86) 21-6023-0333 Fax: (86) 21-5037-2388

**Authorized Distributor:**

©OMRON Corporation 2016-2025 All Rights Reserved.  
In the interest of product improvement,  
specifications are subject to change without notice.

**Cat. No. W555-E2-17 1125**